



Maryland Department of Transportation

*State Highway Administration
Baltimore, Maryland
Competitive Sealed Proposals
Step 2: Request for Proposals (RFP)*

Contract No. AT3765960
F.A.P. No. *(See Cover Sheet)*

**ICC CONTRACT 'A'
DESIGN-BUILD PROJECT**

MD 200

From I-270/I-370 to MD 97

Montgomery County

INSTRUCTIONS TO PROPOSERS

This page is intentionally left blank.

TABLE OF CONTENTS

	<u>Page</u>
SECTION 1.0 INTRODUCTION AND GENERAL PROVISIONS	1
1.1 Introduction	1
1.2 Scope of Work	1
1.3 Project Goals	1
1.4 RFP Documents	2
1.5 Definitions.....	2
1.6 Proposal Schedule	3
1.6.1 Current Schedule.....	3
1.6.2 Proposal Due Date.....	3
1.7 General Provisions Regarding Proposals	3
1.7.1 Proposal Contents	3
1.7.2 Inclusion of Proposal in Contract.....	3
1.7.3 Commitments in the Proposal	4
1.7.4 Property of the Administration.....	4
1.8 Improper Conduct	4
1.8.1 Prohibited Activities	4
1.8.2 Non-Collusion	4
1.8.3 Organizational Conflicts of Interest	4
1.8.4 Restrictions on Participation in Design-Build Contracts	5
1.8.5 State Remedies	5
1.9 Equal Employment Opportunity	6
1.10 DBE Compliance	6
1.11 Resource Availability.....	6
1.12 Licensing Requirements.....	6
1.13 Insurance	7
1.14 Quality Assurance (QA)/Quality Control (QC).....	7
SECTION 2.0 PROCUREMENT PROCESS	7
2.1 Method of Procurement	7
2.2 Receipt of the Request for Proposal Documents and Other Information	7
2.2.1 Administration Designated Point of Contact	7
2.2.2 Rules of Contact.....	8
2.2.3 Proposer Representative.....	9
2.2.4 Language Requirement	9
2.3 Addenda and Responses to Inquiries	9
2.3.1 Addenda	9
2.3.2 Correspondence and Information	10
2.3.3 Responses to Inquiries	10
2.3.4 Date for Issuance of Final Addendum and Responses to Inquiries	10
2.4 One-on-One Meetings.....	10
2.4.1 ATC Meetings.....	10
2.4.2 Post-Proposal Meetings.....	10

2.4.3 Statements at Meetings11

2.5 Non-Public Process11

2.6 Examination of the Request for Proposals Package and Work Site11

2.7 Changes to the Proposer’s Organization12

SECTION 3.0 ALTERNATIVE TECHNICAL CONCEPT REVIEWS12

3.1 Alternative Technical Concepts12

3.2 Submittal and Review of ATCs13

3.3 Contents of ATC Submittal13

3.4 Determination by the Administration14

3.5 Incorporation into Proposal15

3.6 Confidentiality15

SECTION 4.0 SUBMITTAL REQUIREMENTS.....15

4.1 Compliant Proposal15

4.2 General Submittal Requirements16

4.3 Number of Copies16

4.4 Currency17

4.5 Modifications, Withdrawals and Late Submittals17

4.5.1 Modifications17

4.5.2 Withdrawal17

4.5.3 Late Proposals17

4.6 Forfeiture of Proposal Security18

4.7 Cost and Pricing Data18

4.7.1 Delivery of Confidentiality Agreement18

4.7.2 Delivery of Cost and Pricing Data18

4.7.3 Review of Cost and Pricing Data18

4.7.4 Return of Cost and Pricing Data19

4.7.5 Administration Acknowledgment Regarding Cost and Pricing Data19

4.8 No Public Opening19

SECTION 5.0 EVALUATION OF PROPOSALS.....19

5.1 Evaluation Factors and Criteria20

5.1.1 “Pass/Fail” Evaluation Factors20

5.1.2 Technical Evaluation Factors and Their Relative Importance21

5.1.3 Price24

5.1.4 Buy America Provision26

5.2 Evaluation Guidelines26

5.2.1 Technical Evaluation Factors26

5.2.2 Communications27

5.3 Interviews/Presentations27

5.4 Competitive Range27

5.5 Discussions28

5.5.1 Purpose28

5.5.2 Procedures28

5.5.3 Prohibited Conduct29

5.6 Proposal Revisions 29

5.7 Determination of Successful Proposer 30

**SECTION 6.0 CONTRACT AWARD AND EXECUTION; POST-AWARD
ACTIONS 30**

6.1 No Obligation to Award 30

6.2 Contract Award and Execution 30

6.3 Stipend 31

6.4 Debriefing of Unsuccessful Proposers 32

SECTION 7.0 PROTESTS 32

7.1 Written Protests Only 33

7.2 Protest Contents 33

7.3 Time for Filing 33

7.4 Protest Decision 33

7.5 Right of Appeal 34

7.6 Irrevocability of Proposals Pending Resolution of Protest 34

SECTION 8.0 ADMINISTRATION’S RIGHTS AND DISCLAIMERS 34

8.1 Administration’s Rights 34

8.2 Disclaimers 35

Appendices

- A - Technical Proposal Requirements
- B - Price Proposal Requirements
- C - Forms
- D - Updated List of Ineligible Firms

shall also organize the Cost and Pricing Data, labeling each page so that it is obvious that the page is a part of the Cost and Pricing Data and to enable a person reviewing the page out of context to determine where it can be found within the set of documents. Such representatives shall compile an index listing each document included in the Cost and Pricing Data and briefly describing the document and its location in the set of documents. If, following the initial organization, the Administration determines that the Cost and Pricing Data are incomplete, the Administration may require the Proposer to supply data to make the Cost and Pricing Data complete. Failure of the Proposer to supply the required data to the satisfaction of the Administration shall negate the award of the Contract to the Proposer.

Following execution and delivery of the Contract, the Cost and Pricing Data of the successful Proposer will be available for review as specified in DB GP Section 15.

4.7.4 Return of Cost and Pricing Data

Each unsuccessful Proposer shall have the right to pick up any Cost and Pricing Data after the Contract has been executed and delivered, after the Administration rejects all of the Proposals, or after the Administration terminates its procurement, provided that the Administration shall have the right to retain all documents until such time as any protests and related appeals have been resolved.

4.7.5 Administration Acknowledgment Regarding Cost and Pricing Data

The Administration acknowledges that each Proposer considers that the Cost and Pricing Data constitute confidential commercial or financial information. This acknowledgment is based upon the Administration's understanding that the information contained in the Cost and Pricing Data is not known outside each Proposer's business, is known only to a limited extent and by a limited number of employees of Proposer, is safeguarded while in Proposer's possession, and may be valuable to Proposer's construction strategies, assumptions, and intended means, methods, and techniques of design and construction. The Administration acknowledges that the Cost and Pricing Data will at no time be considered the property of the Administration.

4.7.6 Failure to Deliver Cost and Pricing Data

A Proposer's failure to deliver Cost and Pricing Data as required herein is a default and may result in forfeiture of the Proposal Bond.

4.8 NO PUBLIC OPENING

There will be no public opening of Proposals. After the Proposal Due Date, all Proposals will be opened in the presence of two or more Administration employees and reviewed for completeness. A register of Proposals will be prepared that identifies each Proposer.

- Neither the identity of any Proposer nor the register of Proposals will be publicly disclosed until after the Procurement Officer makes a determination recommending award of the Contract.

SECTION 5.0 EVALUATION OF PROPOSALS

The Technical Proposal will be evaluated on the pass/fail and technical evaluation factors identified herein. An evaluation committee (Committee) will determine the pass/fail status and overall technical rating of each Proposal before reviewing information contained in the Price Proposal. After evaluating the Price Proposal, the Committee will prepare a recommendation to the Procurement Officer indicating which Proposal is the most advantageous to the State (i.e., represents the "best value"). The Procurement Officer, together with the Selection Official designated by the Secretary of the Maryland Department of Transportation, will then assess the Committee's recommendation and make a final determination as to which Proposal is the most advantageous to the State considering the technical and price factors set forth in the ITP.

When determining which Proposal is the most advantageous to the State, the Technical and Price Proposals are approximately equal in importance.

The Administration reserves the right to reject any or all Proposals, to waive technicalities, or to advertise for new Proposals, if, in the judgment of the Administration, the best interests of the public will be promoted thereby.

In putting together their Proposals, Proposers should keep in mind and address the PROJECT goals identified in ITP Section 1.3.

5.1 EVALUATION FACTORS AND CRITERIA

The factors identified in ITP Section 5.1.1 will be evaluated on a “pass/fail” basis. The factors identified in ITP Section 5.1.2 will be rated on a qualitative basis. Price will be evaluated as specified in ITP Section 5.1.3.

A Proposal must receive a “pass” on all “pass/fail” evaluation factors listed in ITP Section 5.1.1 for the Proposal to be further evaluated and rated based on the technical evaluation factors identified in Section ITP 5.1.2 and the price factors identified in ITP Section 5.1.3.

5.1.1 “Pass/Fail” Evaluation Factors

Each Proposal must achieve a rating of “pass” on any “pass/fail” evaluation factor listed in ITP Sections 5.1.1.1 through 5.1.1.4 to receive further consideration. Failure to achieve a “pass” rating on any “pass/fail” factor will result in the Proposal being declared unacceptable and the Proposer being disqualified. Prior to making such determination, the Administration may offer a Proposer the opportunity to provide supplemental information or clarify its Proposal, including the opportunity to identify a guarantor and provide financial information for such entity.

5.1.1.1 Legal

The legal pass/fail requirements are as follows:

- A) Provision of a legal opinion on Form OC (Appendix C);
- B) Provision of a properly completed and executed Proposal Affidavit (Appendix C);
- C) Provision of evidence that the Persons proposed to carry out engineering, architecture, landscape architecture, and surveying within the State hold appropriate licenses or that they have the capability to obtain licensure prior to execution of Contract;
- D) Provision of all other specified forms and documents, properly completed and signed (if required) (*see* Appendix A) that do not identify any material adverse information;
- E) The organizational documents shall show that the Proposer has legal capacity to undertake design and construction of the PROJECT, shall include appropriate provisions for management and decision-making within the organization as well as for continuation of the Proposer in the event of bankruptcy or withdrawal of any of its members, and shall otherwise be consistent with PROJECT requirements;
- F) The Principal Participants and key personnel listed in the Proposer’s SOQ shall not have changed since submission of the SOQ or the Proposer shall have previously advised the Administration of a change and received its written consent thereto;
- G) Compliance with any other legal requirements as identified in Appendix A;
- H) Delivery of the Cost and Pricing Data to the Administration as specified in ITP Section 4.7.2.

5.1.1.2 Financial

The financial pass/fail requirements are as follows:

- A) Provision of financial information as specified in Appendix A showing that the Proposer has financial capacity to undertake design and construction of the PROJECT, including the capability to effectively manage the scheduled cash flow as well as any unanticipated cash flow needs of the PROJECT.
- B) In the event that the Proposer was advised that its members and/or their parent companies or other entities were required to provide a guaranty, provision of an irrevocable letter of confirmation from each such entity that it is prepared to provide the guaranty in the required form, as specified in Appendix A.
- C) Provision of all other specified forms and documents, properly completed and signed (if required), and compliance with any other financial requirements, as identified in Appendix A.

5.1.1.3 Other

The pass/fail requirements include provision of all required forms included in Appendix C, properly completed and signed (if required), timely submittal of the Cost and Pricing Data, and all information specified in Appendices A and B shall be provided, in the manner, format, and detail specified, without alteration of the forms except as expressly permitted by the instructions.

5.1.1.4 DBE Compliance

The DBE pass/fail requirements are as follows:

- A) Provision of a DBE utilization affidavit (for more information *see* DB GP-7.21(c)(3));
- B) Provision of a DBE participation schedule, properly completed, that documents the good faith efforts made by the Proposer in submitting the Proposal (for more information *see* DB GP-7.21(c)(4)); and
- C) A DBE Plan detailing how the Proposer will meet its DBE commitments over the course of the Contract.

5.1.2 Technical Evaluation Factors and Their Relative Importance

The technical evaluation factors are as follows:

- A) Environmental
- B) Key Personnel, Experience and Financial Capability;
- C) Management Approach;
- D) Technical Solutions; and
- E) Project Support.

Factor A (Environmental) is more important than any other technical evaluation factor. Factor B (Key Personnel, Experience and Financial Capability), Factor C (Management Approach), and Factor D (Technical Solutions) are of equal importance, followed by Factor E (Project Support).

The technical evaluation factors listed in this Section 5.1.2 and the subfactors listed in ITP Sections 5.1.2.1 through 5.1.2.5 will be evaluated and rated using the evaluation guidelines specified in ITP Section 5.2, with special attention given to the desired quality expressed in the statement of each factor

and/or subfactor. Proposals that receive a technical quality rating of less than "ACCEPTABLE -" for any technical evaluation factor will not be selected for award.

ITP Sections 5.1.2.1 through 5.1.2.5 provide objectives that describe the expectations of the Administration with regard to quality of Work to be performed and the related information to be submitted in the Technical Proposals. Along with the PROJECT Goals (*see* ITP Section 1.3), these objectives will guide the Administration's evaluation of the factors and subfactors.

5.1.2.1 Environmental

Evaluates the Proposer's understanding, approach, capabilities, and commitments with respect to the sensitive and critical environmental needs of the PROJECT.

Objective: Understanding and commitment to the environmental sensitivity of the PROJECT, to include: successful and timely performance of all environmental commitments and permit requirements; design expertise and solutions that respond to environmental concerns; the provision of quality key environmental personnel and specialty subcontractors; real time compliance and stewardship during construction through the development and exceptional execution of plans for environmental compliance, including compliance with noise, air quality, stormwater management and erosion and sediment control requirements; and teamwork with the Administration in the prevention of and the solutions for environmental challenges.

See Appendix A for details regarding this factor and the specific information to be submitted as part of the Proposal.

5.1.2.2 Key Personnel, Experience and Financial Capability

Evaluates the managerial, technical and financial capabilities and experience of the team that the Proposer commits to the PROJECT.

Objective: A highly qualified team of technical experts with expertise in and a record of producing quality work in the critical management and technical positions such as: quality control, safety, key design and construction elements, public information and community outreach, utility coordination, and project controls. Firms and managers experienced in delivering large, quality projects, on or ahead of schedule with environmental and public sensitivity. Firm that is strong financially, with low risk that firm might have difficulty with regard to the scheduled cash flow as well as any unanticipated cash flow needs of the PROJECT.

See Appendix A for details regarding this factor and the specific information to be submitted as part of the Proposal.

5.1.2.3 Management Approach

Evaluates the Proposer's understanding, approach, capabilities, commitments, and organization with respect to scheduling and early completion of the PROJECT and the management of the PROJECT, with emphasis on quality, design, and construction.

Objective: A design-build organization that is designed with clear lines of responsibility and well defined roles that respond to the PROJECT and the Administration; that includes integrated specialty subcontractors and subconsultants; that embraces partnering throughout; that contains the empowerment of all levels of the organization to make decisions in coordination with their Administration counterparts and, if need be, a system to elevate issues to ensure rapid decisions; that encourages and facilitates quality through a well defined and executed quality plans for design and construction; that has a disciplined strategy for design, design quality and design review; that likewise has a comprehensive strategy for

construction management, logistics, hauling, access, construction sequencing, minimizing public disruptions, safety, and on-the-job training. Additionally, a well coordinated network schedule that will reflect the integration of design and construction activities, fast-tracking, construction sequencing, and a shorter time for completion than is called for in the Contract Documents; and a well thought-out Work Breakdown Structure that matches the way the PROJECT will be designed, phased and constructed to facilitate administration and payment.

The Management Approach technical evaluation subfactors are as follows:

- A) Schedule and Time—Evaluates the integrated scheduling of design and construction and the hauling, access, MOT and toll system integration required to achieve early PROJECT completion and to minimize disruption to the environment and the public;
- B) Organization and General Management—Evaluates how well the Proposer is organized for quality, safety, design and construction to achieve the PROJECT's goals;
- C) Design Management—Evaluates how well the Proposer understands and is organized for the integration of design and construction, design quality control, and design review for the PROJECT; and
- D) Construction Management—Evaluates how well the Proposer understands and is organized for the construction of a quality PROJECT along a constrained, environmentally sensitive site, with needs for public outreach, OJT, and empowered problem solving.

All subfactors are of equal importance.

See Appendix A for additional detail regarding this factor and the specific information to be submitted as part of the Proposal.

5.1.2.4 Technical Solutions

Evaluates the Proposer's understanding, approach, capabilities, innovation and commitments to the delivery of design and construction solutions that are environmentally and aesthetically compatible, durable, safe and maintainable.

Objective: Innovative design solutions that respond to: the environmental and community sensitivities and commitments; the context sensitive design and toll road nature of the highway, bridges and structures, the requirement for a coordinated aesthetic theme that includes bridges, walls, signing, landscaping, and toll and intelligent transportation structures; quality pavements, geotechnical challenges; and the well planned and coordinated design and relocation of utilities.

The Technical Solutions technical evaluation subfactors are as follows:

- A) Bridge, Structures and Aesthetic Design Concepts—Evaluates how creative and innovative the Proposer is in design and construction solutions to the bridge, structure and aesthetic challenges of the PROJECT;
- B) Roadway Design Concepts—Evaluates how well the Proposer understands and solves the roadway, traffic, ITS and ETC design and construction challenges of the PROJECT and the interaction and coordination required to integrate the toll systems;
- C) Pavement Design—Evaluates how well the Proposer understands and addresses in design solutions the pavement material, subgrade, tie-in, and safety needs of the PROJECT;

- D) Landscape and Planting Concepts—Evaluates how well the Proposer understands and responds to the landscaping needs of the PROJECT, including its relationship with all design and construction elements and operations;
- E) Geotechnical—Evaluates how well the Proposer understands and proposes to solve the geotechnical investigation, slope and earth stability, and monitoring risks of the PROJECT; and
- F) Utility Relocations—Evaluates the Proposer’s understanding and plan for the successful coordination of all PROJECT utility relocations, including both those designed and constructed by the utilities and by the Proposer.

Subfactor (A) is of higher importance than others, while subfactors (B), (C), (D), (E), and (F) are of equal importance.

See Appendix A for additional detail regarding this factor and the specific information to be submitted as part of the Proposal.

5.1.2.5 Project Support

Evaluates the Proposer’s understanding, capability, approach, and commitments to successful interaction with the public, the railroad(s) and the Administration through a hub office concept.

Objective: Quality planning and execution in: the support of the Administration in community relations, public information and community outreach; maintenance of traffic that responds to the needs of the PROJECT, the adjacent communities and the traveling public; site and public access; railroad coordination; and the provision and operation of a PROJECT hub office.

See Appendix A for details regarding this factor and the specific information to be submitted as part of the Proposal.

5.1.3 Price

The Proposer shall submit its Price Proposal for the PROJECT in accordance with Appendix B. Specific information to be submitted is identified in Appendix B. Refer to DB GP Section 9 for information regarding payment procedures.

The Proposer shall base its Price Proposal on the following assumptions regarding the Administration’s authorization to perform and complete the Work.

- A) Within the time prescribed in DB GP-8.02, the Administration will issue a limited Notice to Proceed requiring the Design-Builder to proceed with the following work;
 - 1) All of the design work required to construct and complete the PROJECT;
 - 2) Environmental training;
 - 3) Coordination with utility owners and other stakeholders;
 - 4) Development of the Quality Plan, the initial Baseline Project Schedule, and the initial Contract Payment Schedule; and
 - 5) Establishment of Project Hub Office.
- B) The Administration will issue full Notice to Proceed, requiring the Design-Builder to proceed with all remaining Work, with an effective date no later than 45 days after the limited Notice to Proceed described in paragraph (A), above.

- C) The Design-Builder shall complete the Work on or before the following deadlines;
 - 1) For Acceptance for Maintenance: June 18, 2010; and
 - 2) For Final Completion: 60 days after the deadline date for Acceptance for Maintenance.

The following factors will be considered in the price evaluations:

- A) Proposal Price;
- B) Consistency of the Proposal Periodic Payment schedule (Form PPS-P) with the proposed Baseline Progress Schedule;
- C) Price Accuracy, Completeness, and Reasonableness as reflected in the Schedule of Prices (Form SP-1, Appendix C); and
- D) Cash Flow Curve.

Each Price Proposal shall specify the sum for which the Work will be performed according to the RFP (the Proposal Price). Cost or pricing data submitted with the Price Proposal shall be certified by each Proposer as accurate, complete and current to the best of the Proposer's knowledge and belief.

The Administration reserves the right to reject any Proposal if it determines that the Price Proposal is unacceptable, including a determination that the Proposal is significantly unbalanced or front end loaded to the potential detriment of the Administration.

An unbalanced Proposal is considered to be one (a) which is front-loaded or (b) for which the line item amounts or amounts shown in the Schedule of Prices do not reflect reasonable actual costs plus a reasonable proportionate share of the Proposer's anticipated profit, overhead costs, and other indirect costs which are anticipated for the performance of the items in question.

Prices shall be indicated in words and figures. In case the amount shown in words and its equivalent in figures do not agree, the written words may, in the discretion of the Administration, be considered binding.

The Proposer's attention is directed to the fact that it cannot exceed two decimal positions in the cents column.

A Price Proposal shall be deemed unacceptable if the Administration determines, in its sole discretion, that it fails to conform to the conditions of the RFP in any manner. A Price Proposal may be unacceptable if it:

- A) Is significantly unbalanced relative to the scope of the Work;
- B) Does not provide all information in conformance with the Instructions to Proposers;
- C) Contains a Proposal Periodic Payment schedule (Form PPS-P) that is significantly inconsistent with the proposed Baseline Progress Schedule; and/or
- D) Contains inaccurate, incomplete, and/or unreasonable prices on Form SP-1 (Appendix C).

The Proposal Price shall be the Contract Price if the Contract is awarded to the Proposer, unless the certified cost or pricing data submitted with the Proposal is subsequently found to have been inaccurate, incomplete, or noncurrent as of the effective date of the certification, in which case the Administration

shall be entitled to an adjustment of the Contract Price, including profit or fee, to exclude any sum by which the Contract Price was increased because of the defective data.

5.1.4 Buy America Provision

The Proposer shall comply with Section 165 of the Surface Transportation Assistance Act of 1982, as amended by Section 1041(a) and 1048(a) of the Intermodal Surface Transportation Efficiency Act of 1991, with regard to the furnishing and coating of iron and steel products. A nationwide waiver for this provision has been granted for pig and scrap iron, processed, pelletized, and reduced iron ore, and raw alloys.

Each Proposer shall submit a Proposal using domestic iron and steel products with coatings that have been applied inside the United States ("Domestic Products"). If the Proposer elects, its Proposal may be submitted using foreign products on one or more of the above items ("Foreign Products"), in which case the Proposer shall submit in the Price Proposal a completed Form BA. (See Appendix C.)

Subject to ITP Section 6, below, the Contract, if awarded, will be awarded to the Proposer who submits a Proposal based on furnishing Domestic Products, unless such Proposal exceeds the lowest total Proposal based on furnishing Foreign Products by more than twenty five percent (25%). Foreign Products will not be permitted to be used as a substitution for Domestic Products after the Contract has been awarded.

When Domestic Products are used in a project, the Proposer is not prohibited from using a minimal amount of Foreign Products if the cost of such materials used does not exceed one-tenth of one percent (0.1 percent) of the total contract cost or \$2,500, whichever is greater.

5.2 EVALUATION GUIDELINES

5.2.1 Technical Evaluation Factors

The technical evaluation factors, subfactors, and requirements identified in ITP Section 5.1.2 (not the "pass-fail" factors) will be evaluated in accordance with the guidelines provided in this Section 5.2.1. The technical evaluation factors and the overall Technical Proposal will be rated by an adjectival (qualitative/descriptive) method. The following adjectival ratings shall be used in evaluation of each subfactor, technical evaluation factor and the overall technical rating of the Proposal:

EXCEPTIONAL: The Proposer has demonstrated an approach that is considered to significantly exceed stated objectives/requirements in a way that is beneficial to the Administration. This rating indicates a consistently outstanding level of quality, with very little or no risk that this Proposer would fail to meet the requirements of the solicitation. There are essentially no weaknesses (as such term is defined below).

GOOD: The Proposer has demonstrated an approach that is considered to exceed stated objectives/requirements. This rating indicates a generally better than acceptable quality, with little risk that this Proposer would fail to meet the requirements of the solicitation. Weaknesses, if any, are very minor.

ACCEPTABLE: The Proposer has demonstrated an approach that is considered to meet the stated objectives/requirements. This rating indicates an acceptable level of quality. The Proposal demonstrates a reasonable probability of success. Weaknesses are minor and can be readily corrected.

SUSCEPTIBLE TO BECOME ACCEPTABLE: The Proposer has demonstrated an approach that fails to meet the stated objectives/requirements, as there are weaknesses and/or deficiencies, but they are susceptible to correction through Discussions. The response is considered marginal in terms of the basic

content and/or amount of information provided for evaluation but overall, the Proposer is capable of providing an acceptable or better Proposal.

UNACCEPTABLE: The Proposer has demonstrated an approach that indicates significant weaknesses/deficiencies and/or unacceptable quality. The Proposal fails to meet the stated objectives/requirements and/or lacks essential information and is conflicting and/or unproductive. There is no reasonable likelihood of success; weaknesses/deficiencies are so major and/or extensive that a major revision to the Proposal would be necessary.

In assigning ratings the Administration may assign "+" or "-" (such as, "Exceptional -", "Good +", and "Acceptable +") to the ratings to better differentiate within a rating in order to more clearly differentiate between the technical evaluation factors and the overall Proposals.

The term "weakness," as used herein, means any flaw in the proposal that increases the risk of unsuccessful contract performance. A significant weakness in the proposal is a flaw that appreciably increases the risk of unsuccessful contract performance. The term "deficiency" means a material failure of a proposal to meet an RFP requirement or a combination of significant weaknesses in a proposal that increases the risk of unsuccessful contract performance to an unacceptable level.

Certain technical evaluation factors include subfactors relating to the different technical disciplines (i.e., structures; highways; landscaping) or different management areas (i.e., design; construction) involved in the evaluation. Each subfactor will be assigned a consensus rating, and all subfactors under a technical evaluation factor will be combined through consensus, taking into account the relative importance of each subfactor (*see* ITP Sections 5.1.2.1 through 5.1.2.5), to arrive at an overall rating for each such factor. Technical evaluation factors without subfactors will also be assigned a consensus rating. The ratings of all the technical evaluation factors will then be combined by consensus, taking into account the relative importance of the evaluation factors (*see* ITP Section 5.1.2), to arrive at the overall rating for the Technical Proposal.

5.2.2 Communications

The Administration may engage in communications with the Proposers after receipt of Proposals, allowing Proposers to provide clarifications to their Proposals or otherwise to address issues that might prevent the Proposal from being placed in the Competitive Range. This process will be initiated by delivery of a written request from the Administration to the Proposer identifying the information needed and a date and time by which the information must be provided. The Proposer shall provide the requested information in writing by the date and time indicated. If the requested information is not timely received, the Proposer's ratings may be adversely affected and/or the Proposal may be declared unacceptable.

5.3 INTERVIEWS/PRESENTATIONS

The Administration may meet with and receive presentations and conduct interviews with Proposers prior to determining the Competitive Range.

5.4 COMPETITIVE RANGE

The term "Competitive Range" means a list of the most highly rated Proposals, based on initial Technical Proposal ratings and evaluations of Price Proposals, that are judged by the Procurement Officer to be reasonably susceptible of being selected for award. The Competitive Range is based on the rating of each Technical Proposal and evaluation of each Price Proposal against all evaluation criteria.

Proposals that would not be included in the Competitive Range and would be excluded from further consideration include:

- A) Any Proposal that, even after review of supplemental information or clarification provided by the Proposer in response to an Administration request does not pass the pass/fail evaluation factors;
- B) A Proposal that, after the initial evaluation, is rated lower than "SUSCEPTIBLE TO BECOME ACCEPTABLE" for any technical evaluation factor (ITP Section 5.1.2) or subfactor (ITP Sections 5.1.2.1 through 5.1.2.5); and/or
- C) Any Proposal that includes a Price Proposal that is considered unacceptable or is priced so high as to be effectively non-competitive.

The Administration will determine the Competitive Range after a careful analysis of the Technical and Price Proposals. The Competitive Range will include all Proposers whose Proposals are judged by the Procurement Officer to be reasonably susceptible of being selected for award. Proposals will not be excluded from further consideration if the Proposers have a reasonable chance of being placed in the Competitive Range if meaningful Discussions are conducted and appropriate improvement is achieved.

5.5 DISCUSSIONS

The Administration reserves the right to make an award without Discussions. However, the Administration may, at its sole discretion, conduct Discussions (that is, written or oral exchanges) with the Proposers in the Competitive Range, with the intent of allowing the Proposers to revise their Proposals.

5.5.1 Purpose

If the Administration decides to engage in Discussions, the areas of Discussions may include the following:

- A) Advising the Proposers of weaknesses, significant weaknesses, and/or deficiencies in their Proposals (relative to the RFP);
- B) Attempting to resolve any uncertainties and obtaining any significant additional understanding concerning the Proposal;
- C) Resolving any suspected mistakes by calling them to the attention of the Proposers as specifically as possible without disclosing information concerning other competing Proposals or the evaluation process;
- D) Providing the Proposers a reasonable opportunity to submit any further technical or other supplemental information to their Proposals;
- E) Obtaining the best price for the State; and
- F) Facilitating execution of a contract that is most advantageous to the State taking into consideration the technical and price factors discussed above.

5.5.2 Procedures

The following specific procedures will apply to Discussions:

- A) Discussions will only be conducted with Proposers in the Competitive Range. If Discussions are held, they will be held with all Proposers in the Competitive Range;
- B) Information disclosed by Proposers in the Competitive Range during Discussions will not be made public until after execution of the Contract (*see* ITP Section 2.5);

- C) Discussions may be written and/or oral, and more than one round of Discussions may be conducted; and
- D) No disclosure will be made of any information derived from a Proposal of, or from discussions with, another Proposer.

5.5.3 Prohibited Conduct

During Discussions, Administration personnel involved in the acquisition shall not engage in the following conduct:

- A) Revealing a Proposer's technical solution, including unique technology, innovative and unique uses of commercial items, or any information that would compromise a Proposer's intellectual property to another Proposer;
- B) Revealing a Proposer's price without that Proposer's permission. However, the Administration may inform a Proposer that its price is considered by the Administration to be too high or too low and may provide information regarding the analysis supporting that conclusion;
- C) Revealing the names of individuals providing reference information about a Proposer's past performance; or
- D) Revealing selection information in violation of the Administration's procurement policies and the laws of the State.

5.6 PROPOSAL REVISIONS

Although the Administration reserves the right to hold Discussions and request revised Proposals (also known as best and final offers or BAFOs) when in the best interest of the State, the Administration is under no obligation to do so. The Administration may make its selection and award based on the initial Proposals as submitted.

At the conclusion of Discussions (if held), the Administration will request BAFOs from all Proposers in the Competitive Range to provide Proposers an opportunity to revise their Proposals (both technical and price), including correction of any weaknesses, minor irregularities, errors, and/or Deficiencies identified to the Proposers by the Administration following initial evaluation of the Proposals. The request for BAFOs will allow adequate time, as determined by the Administration, for the Proposers to revise their Proposals. Upon receipt of the BAFOs, the process of evaluation will be repeated. The process will consider the revised information and re-evaluate and revise ratings as appropriate.

The Administration may require more than one series of BAFO submissions, but only if the State Highway Administrator or designee makes a written determination that it is in the State's best interest to conduct additional Discussions following receipt of BAFOs or to change the Administration's requirements and require another BAFO submission. .

In the event that any Proposer requested to submit a BAFO fails to provide a BAFO, or delivers a BAFO that is deemed unacceptable or late, the Administration shall have the right to consider as valid such Proposer's initial Proposal and to award the Contract to such Proposer based on its initial Proposal. All terms and conditions of this ITP applicable to Proposals shall also be applicable to BAFOs except as otherwise specified in the request for BAFOs.

5.7 DETERMINATION OF SUCCESSFUL PROPOSER

In accordance with COMAR 21.05.03.03(F), award of the Contract based on a determination of the Proposal that is the most advantageous to the State taking into consideration the technical and price factors discussed above provides the best opportunity to obtain the right Design-Builder to assure a successful PROJECT.

In order to be considered for award of the Contract, a Proposal must pass all the pass/fail factors, receive at least an "ACCEPTABLE -" on all technical evaluation factors except Environmental, and receive a "GOOD" rating or better on the Environmental technical evaluation factor.

SECTION 6.0 CONTRACT AWARD AND EXECUTION; POST-AWARD ACTIONS**6.1 NO OBLIGATION TO AWARD**

The Administration shall be under no obligation to award the Contract to the Proposer submitting the lowest priced Proposal or to award the Contract at all.

6.2 CONTRACT AWARD AND EXECUTION

Unless all Proposals are rejected or this procurement is canceled, the Contract shall be awarded to the responsible Proposer offering an acceptable Proposal that is the most advantageous to the State taking into consideration the technical and price factors discussed above.

Within 10 days after notice of award of the Contract is provided to the selected Proposer, the selected Proposer shall:

- A) Notify the Administration in writing of the name and address of its agent for service of legal process for this PROJECT. The Proposer shall not change that authorized agent without prior written notice to the Administration; and
- B) Provide the Administration, in writing, Proposer's Federal Internal Revenue Service Employer Identification Number.

Within 10 days of the date of the delivery of the form of Contract, conformed for execution, to the successful Proposer by the Administration, the selected Proposer shall deliver to the Administration the following:

- A) The executed Contract, together with evidence (if not previously provided) as to the authority, power, and capacity of said individuals to bind the Proposer to the Contract;
- B) Required Payment and Performance Bonds - *See Appendix C*;
- C) Insurance certificates - *See Appendix C*;
- D) Executed guaranties - *See Appendix C*;
- E) Updated opinion of counsel on Form OC (with regard to Contract and guaranties);
- F) Evidence that the Proposer and its team members hold all required licenses, if not previously provided; and

A5.1 ENVIRONMENTAL COMPLIANCE SUMMARY INFORMATION FOR VOLUME 2 OF THE TECHNICAL PROPOSAL

The Proposer shall submit a summary of the following portions of an Environmental Compliance Plan in Volume 2 of the Technical Proposal, describing how the Proposer will execute and perform its Contract responsibilities in environmental compliance and minimize impacts to box turtles (*see* Section 4.0 of PS 310-Environmental Performance Specification for a complete description of the Environmental Compliance Plan) (15 pages maximum for summary plan):

- A) Description of how the Proposer's environmental compliance team (Environmental Manager and staff and the environmental compliance firm) will achieve full compliance with the environmental commitments, considerations, permit conditions and approval requirements for design and construction;
- B) Description of how and where the Proposer's environmental compliance team proposes to further avoid and/or minimize impacts to forests, 4(f) parklands, wetlands and waters of the United States;
- C) Narrative and graphics that clearly illustrate the Proposer's environmental compliance team's process, structure, organization chart identifying key environmental compliance team members under the Environmental Manager, location and methods proposed for documentation, communication and environmental QC; and
- D) A paragraph (no more than half a page each) for each of the key environmental compliance team members identified on the organization chart specifying their experience related to the PROJECT.
- E) Brief summary of how impacts to animals (especially box turtles) will be minimized, including relocating animals and restricting access both before clearing of the Right-of-Way and during construction.
- F) Description/outline of how Proposer's environmental compliance team proposes to develop, implement and administer an environmental compliance and awareness training program. In addition, provide a list of topics that may be included in the training program.

A5.2 KEY ENVIRONMENTAL PERSONNEL INFORMATION FOR VOLUME 2 OF THE TECHNICAL PROPOSAL

The Proposer shall submit Form KEP, Key Environmental Personnel (*see* Appendix C) in Volume 2 of the Technical Proposal regarding their key environmental personnel (*see* SP 115 for experience requirements). Form KEP also includes a column for time commitments to the PROJECT. For this reason, the Environmental Manager, for whom information was provided in the SOQs, has been added to Form KEP to obtain a time commitment only. (Note: there is a full-time requirement for the Environmental Manager; therefore, Form KEP already reflects a 100% time commitment for this manager.)

A5.3 KEY ENVIRONMENTAL PERSONNEL INFORMATION FOR APPENDIX A OF THE TECHNICAL PROPOSAL

The Proposer shall submit resumes (1 page maximum for each person), highlighting their experience related to the PROJECT for the key environmental personnel listed on Form KEP in Appendix A to the Technical Proposal.

A5.4 STORMWATER MANAGEMENT AND DRAINAGE INFORMATION FOR VOLUME 2 OF THE TECHNICAL PROPOSAL

The Proposer shall submit the following information in Volume 2 of the Technical Proposal in support of its approach for drainage, erosion and sediment control, and stormwater management:

- A) Concept Earth Disturbance Area (EDA) plan (see PS 303, Section 3.8.1.C) that outlines how the Proposer proposes to phase construction of the PROJECT from an erosion and sediment control perspective to maximize protection of downstream resources and property from construction related sedimentation. The concept EDA plan shall identify elements critical to the success of the plan, e.g. early construction of a culvert at Sta. XX that is required to construct a haul road from point A to point B, etc.;
- B) An underground SWM narrative describing the approach that the Proposer proposes to take toward design of underground SWM systems for quantity only, and for quantity and quality control of stormwater, including how maintenance access would be provided to underground SWM facilities, and how the Proposer's proposed system would keep the cost of long term maintenance low (2 pages maximum); and
- C) SPA and Use III Waters SWM narrative describing the approach that the Proposer would take to address thermal discharges of stormwater into Use III streams and the scientific basis for the approach (2 pages maximum).

A6.0 KEY PERSONNEL, EXPERIENCE AND FINANCIAL CAPABILITY

A6.1 KEY PERSONNEL INFORMATION FOR VOLUME 3 OF THE TECHNICAL PROPOSAL

The Proposer shall submit the following information in Volume 3 of the Technical Proposal regarding their key environmental personnel (*see* SP 115 for experience requirements):

- A) Form KP, Key Personnel (see Appendix C). Form KP also includes a column for time commitments to the PROJECT. For this reason, the Key Managers, for whom information was provided in the SOQs, have been added to Form KP to obtain time commitments only (Note: there is a full-time requirement for the Project Manager and the Project Quality Manager; therefore, Form KP already reflects a 100% time commitment for these managers); and
- B) The RCL notification letter advised an adjustment in the qualification requirements for the Project Quality Manager and a change in the role of the Community Outreach Manager (see SP 115). If the Proposer submits and obtains approval to substitute for one or both of these key managers (see RFQ Section A.17), the Proposer shall provide the information required on the new managers in Form KP and a resume.

A6.2 KEY PERSONAL INFORMATION FOR APPENDIX A OF THE TECHNICAL PROPOSAL

The Proposer shall submit resumes (1 page maximum) for the key personnel (except for Key Managers) listed on Form KP in Appendix A of the Technical Proposal.

A6.3 EXPERIENCE INFORMATION FOR VOLUME 3 OF THE TECHNICAL PROPOSAL

The Proposer shall submit information in Volume 3 of the Technical Proposal that addresses those issues identified under "concerns and opportunities for improvement" if any in the RCL notification letter dated March 17, 2006 (total 4 pages maximum).



Maryland Department of Transportation

*State Highway Administration
Baltimore, Maryland
Competitive Sealed Proposals
Step 2: Request for Proposals (RFP)*

Contract No. **AT3765960**
F.A.P. No. *(See Cover Sheet)*

**ICC CONTRACT 'A'
DESIGN-BUILD PROJECT**

MD 200

From I-270/I-370 to MD 97

Montgomery County

Part 3, Design Requirements

THIS PAGE LEFT INTENTIONALLY BLANK

TABLE OF CONTENTS

1.0 INTRODUCTION 1

1.1 PURPOSE..... 1

2.0 DESIGN REQUIREMENTS 1

2.1 SCOPE..... 1

2.2 PROCEDURES 2

 2.2.1 Format 2

 2.2.2 Deviations 2

2.3 DESIGN CODES AND MANUALS 3

2.4 HISTORIC PRESERVATION..... 3

2.5 PROJECT-SPECIFIC DESIGN PARAMETERS..... 3

3.0 PERFORMANCE SPECIFICATIONS 3

3.1 STANDARDS AND REFERENCES 3

3.2 RELATION TO PART 6 – REQUEST FOR PROPOSALS PLANS..... 4

3.3 LIST OF PERFORMANCE SPECIFICATIONS 4

3.4 LIST OF APPENDICES 4

DESIGN REQUIREMENTS

1.0 INTRODUCTION

1.1 PURPOSE

This Part 3 – Design Requirements and Performance Specifications establishes basic design and performance requirements to be used in the design and construction of the Project. In addition, Directive and Indicative Plans (*see* Part 6 – Request for Proposals Plans) have been prepared during the Administration’s Conceptual and Preliminary Engineering to provide standards for and guide the design activities through Final Design and the preparation of procurement and construction documents.

Section 2.0, Design Requirements, provides direction on certain aspects of design applicable throughout the Project and the requirements to be followed for the design in the event a Project element or component is not covered by a Performance Specification.

Section 3.0, Performance Specifications, includes both the broad design and performance parameters, usually in the form of recognized standards, under which components and elements of the Project are to be designed and the specifically defined design and performance requirements relative to the Project. The Performance Specifications also relate the applicability of the Plans contained in Part 6 – Request for Proposals Plans and Part 7-Engineering Data.

2.0 DESIGN REQUIREMENTS

The Project is bound by Agreements and Commitments to Federal, State, local agencies, and local communities for the entire InterCounty Connector that are documented by the Record of Decision (ROD) and Final Environmental Impact Statement (FEIS), which are included as Reference Documents. The Administration has created a Commitment Tracking Database (CTD), which is included as Appendix C to this Part 3, of all unique Project Commitments to which the Design-Builder shall perform. The CTD contains commitments and considerations that have been excerpted from the FEIS, ROD, USACE permit and the MDE water quality certification and nontidal wetland and waterway construction permit. The Design-Builder shall obtain clarification for any perceived conflicts or ambiguity between the requirements found in the Commitment Tracking Database and those identified elsewhere in the RFP prior to proceeding with design or construction.

2.1 SCOPE

Certain design requirements, both broad and flexible as defined by standards and references and Project specific as defined under Section 2.6, are contained in each Performance Specification and govern the design of that Project element. Each Performance Specification lists the precedence of the design requirements.

In the case where a Project element cites the design and construction criteria as the Maryland Department of Transportation, State Highway Administration’s (Administration) Standard Specifications for Construction and Materials, the performance shall be governed by Part III-Technical Requirements of the most recent edition including special provisions and special provision inserts, and all other applicable engineering codes and standards. . Refer to Part 7-Engineering Data for supplemental special provisions and special provision inserts. Appendix A to this Part 3 identifies those performance criteria of Part III-Technical Requirements that are standard and reference.

References contained within Part III-Technical Requirements to either PART I-General Provisions or Part II-Terms and Conditions of the Administration's Standard Specifications for Construction and Materials shall be disregarded. Citations within the Administration's Standard Specification for Construction and Materials for "Measure and Payment" shall be disregarded. Governance within the Standard Specification for Construction and Materials pertains to technical requirements only and shall not be considered a revision nor modification to DB GP Section 9, Price, Progress and Payment.

The term "Engineer" when used in the Standard Specification for Construction and Materials shall be considered the Design-Builder's Responsible Engineer for the respective Design Unit unless otherwise stipulated., in which case the term "Engineer" shall be identified as the Administration's Authorized Representative. Refer to Appendix D of this Part 3 for the definition of the term "Engineer" when cited within the Standard Specification for Construction and Materials.

The term "Contract Documents" when used in the Administration's Standard Specifications for Construction and Materials will mean the Design-Builder's plans and Specifications released for construction, as outlined in DB GP Section 11.

The term "Contractor" when used in the Administration's Standard Specification for Construction and Materials will refer to the Design-Builder.

Design details shall be in accordance with the MDSHA (Administration) Book of Standard for Highways, Incidental Structures and Traffic Control Applications for details identified as standard. Appendix B to this Part 3 identifies those design details that are standard and reference.

2.2 PROCEDURES

2.2.1 Format

The Design-Builder shall prepare Design Plans and Specifications for the Project in accordance with the Administration's standards for general content, format and in accordance with the Contract.

2.2.2 Deviations

Deviations may be made within the framework of these design requirements to meet the requirements of this Section 2.0 and the Performance Specifications to meet the requirements of a particular problem. However, any deviation, discrepancy, or unusual solution requires Approval by the Administration before it can be included in the design. It is the responsibility of the Design-Builder to identify, explain, and justify any deviation from the established criteria and to secure the necessary Approval from the Administration.

2.3 SUPPORTING ENGINEERING INFORMATION

2.3.1 Mapping

Existing mapping information is contained in Part 7-Engineering Data

2.3.2 Surveying

Existing surveying information is contained in Part 7-Engineering Data

2.3.3 Geotechnical

Existing geotechnical data is contained in Part 7-Engineering Data. The Design-Builder shall conduct additional subsurface exploration, geotechnical investigations, analyses, design and construction in accordance with the Geotechnical Performance Specification.

2.3.4 CADD

CADD formatting for Design and As-Built

2.3.5 Traffic Data

Traffic data is contained in Part 7-Engineering Data.

2.4 DESIGN CODES AND MANUALS

In addition to these requirements listed in this Section 2.0 and the Performance Specifications, the Design-Builder shall comply with applicable and currently effective engineering codes and standards, including those of the various federal, state, and local jurisdictions.

If codes, standards, and/or manuals are specified herein for the design of an element of the Project, then the edition(s) in effect at the date of issuance of the Request for Proposals (RFP) or date of subsequent addendum revising the code or manual shall be applicable to the Project. Responsibility for design remains with the Design-Builder in accordance with the terms and conditions of the Contract. If a code, manual, or standard is subsequently modified after issuance of the RFP, the Design-Builder shall notify the Administration of such modification(s) and request the Administration's decision regarding application of the modification(s). If the Administration directs the Design-Builder to comply with the modifications and any change in the cost or time of performance results, such change will be covered by a Contract Modification.

Specific codes and standards that are included in the Performance Specifications include, but are not limited to, the following:

- A) AASHTO A Policy on Geometric Design of Highways and Streets (Green Book);
- B) AASHTO Roadside Design Guide, and
- C) Manual of Uniform Traffic Control Devices (MUTCD).

2.5 HISTORIC PRESERVATION

Historic preservation shall comply with the Environmental Performance Specification.

2.6 PROJECT-SPECIFIC DESIGN PARAMETERS

Project-specific design parameters are included under their appropriate and respective Performance Specifications. Project-specific design parameters may include, but are not limited to, design parameters specific to the Project, such as, bridge loadings, design life, design speed, forecasted traffic volumes, number of lanes and lane widths, stopping sight distance, horizontal curvature, superelevation, vertical curves, horizontal and vertical alignments, grades, and roadside clear zone width.

3.0 PERFORMANCE SPECIFICATIONS

The Performance Specifications included in this Part 3 – Design Requirements and Performance Specifications establish requirements that the Design-Builder's Work shall achieve. The Performance Specifications are intended to provide clear requirements for how the finished product is to perform while allowing the Design-Builder considerable flexibility in selecting the design, means, materials, components, and construction methods used to achieve the specified performance.

3.1 STANDARDS AND REFERENCES

Standards and references are cited within the Performance Specifications. The following distinction between "standards" and "references" applies. Standards constitute a further elaboration of the requirement. References constitute advisory or information material, provided for the Design-Builder's benefit, that need not be followed but in some cases provides solutions already in use by the

Administration. In some cases, specific parts of references are cited in performance specifications as standards.

3.2 RELATION TO PART 6 – REQUEST FOR PROPOSALS PLANS

The Performance Specifications contained in this Part 3 – Design Requirements and Performance Specifications also govern the applicability of the Request for Proposals Plans contained in Part 6 – Request for Proposals Plans. Individual Performance Specifications establish which of the Request for Proposals Plans apply and the extent to which those Request for Proposals Plans apply. Indicative Plans are, for the most part, for reference as described in Section 3.1. The presence or lack of presence of an indicative plan, or the lack of a directive plan, relative to an element or component of the Project should not be interpreted as reducing the flexibility or range of choices provided to the Design-Builder under a performance specification. Part 6 – Request for Proposals Plans further addresses the distinction between directive and indicative Plans and the applicability of directive and indicative Plans.

3.3 LIST OF PERFORMANCE SPECIFICATIONS

The following is a list of the performance specifications contained in this Part 3 – Design Requirements and Performance Specifications:

- 301-Planting and Landscape Architectural
- 302-Public Outreach
- 303-Drainage
- 304-Geotechnical
- 305-Traffic
- 306-Maintenance of Traffic
- 307-Pavement
- 308-Structures
- 309-Roadway
- 310-Environmental
- 311-Electronic Toll Collection
- 312-Intelligent Transportation System

3.4 LIST OF APPENDICES

- Appendix A- Standard Specifications for Construction and Materials
- Appendix B- Book of Standards for Highways, Incidental Structures and Traffic Control Applications
- Appendix C- Commitment Tracking Database
- Appendix D- Definition of the Term “Engineer”



Maryland Department of Transportation

*State Highway Administration
Baltimore, Maryland
Competitive Sealed Proposals
Step 2: Request for Proposals (RFP)*

Contract No. AT3765960

F.A.P. No. *(See Cover Sheet)*

**ICC CONTRACT 'A'
DESIGN-BUILD PROJECT**

MD 200

From I-270/I-370 to MD 97

Montgomery County

**Part 3, Design Requirements
Performance Specifications**

THIS PAGE LEFT INTENTIONALLY BLANK

TABLE OF CONTENTS

PS 301 - PLANTING & LANDSCAPE ARCHITECTURAL PERFORMANCE SPECIFICATION	1
PS 302 - PUBLIC OUTREACH PERFORMANCE SPECIFICATION	33
PS 303 - DRAINAGE PERFORMANCE SPECIFICATION	38
PS 304 - GEOTECHNICAL PERFORMANCE SPECIFICATION	65
PS 305 - TRAFFIC PERFORMANCE SPECIFICATION	88
PS 306 - MAINTENANCE OF TRAFFIC (MOT), HAUL ROUTES AND ACCESS DURING CONSTRUCTION PERFORMANCE SPECIFICATION	110
PS 307 - PAVEMENT PERFORMANCE SPECIFICATION	126
PS 308 - STRUCTURES PERFORMANCE SPECIFICATION	145
PS 309 - ROADWAY PERFORMANCE SPECIFICATION	168
PS 310 - ENVIRONMENTAL PERFORMANCE SPECIFICATION	180
PS 311 - ELECTRONIC TOLL COLLECTION PERFORMANCE SPECIFICATION	205
PS 312 - INTELLIGENT TRANSPORTATION SYSTEMS (ITS)_PERFORMANCE SPECIFICATION	223

**PS 301 – PLANTING & LANDSCAPE ARCHITECTURAL
 PERFORMANCE SPECIFICATION**

1.0 GENERAL

The Design-Builder shall design and construct Landscape Architecture and plantings associated with the Project in accordance with this specification.

This Project requires particular attention to the aesthetic and landscape architectural design elements of the highway corridor. The Project corridor traverses through a variety of existing land use types that include: residential, urban, open landscape, parkland, and riparian buffer/stream valleys. The Project corridor also includes an historic structure site and discrete access nodes/community gateways.

2.0 STANDARDS AND REFERENCES

2.1 STANDARDS

Design and construct the Landscape & Aesthetics in accordance with the relevant requirements of the Standards listed by priority in Table 1, unless otherwise stipulated in this specification. Standards specifically cited in the body of this specification establish requirements that shall have precedence over all others. Should the requirements in any Standard below conflict with those in another, the Standard listed with the higher priority shall govern. It is the Design-Builder’s responsibility to obtain clarification for any unresolved or perceived ambiguity prior to proceeding with design or construction.

Use the most current version of each listed Standard as of the initial Publication Date of this RFP.

**Table 1
 Standards for Landscape**

Priority	Author or Agency	Title
1	SHA	Standard Specifications for Construction and Materials for items identified as Standard in Attachment A of Part 3-Design Requirements
2	SHA	Integrated Vegetation Management Manual for Maryland Highways
3	MDE	2000 Maryland Stormwater Design Manual, Appendix A, Landscaping Guidance for Stormwater BMPs
4	FHWA/MSHP O/MdTA/SHA	Memorandum of Agreement Among the Federal Highway Administration, The Maryland State Historic Preservation Officer, The Maryland Transportation Authority and The Maryland State Highway Administration regarding The Intercounty Connector Project, Section I: Treatment of Architectural Historic Properties, Item A: J. H. Cashell Farm (M: 22-25)
5	ANSI A300 (Part 1)	Tree Care Operations – Tree, Shrub and Other Woody Plant Maintenance – Standard Practices
6	ANSI A300 (Part 2)	Tree Care Operations – Tree, Shrub and Other Woody Plant Maintenance – Standard Practices – Part 2 – Fertilization
7	ANSI A300 (Part 3)	Tree Care Operations – Tree, Shrub and Other Woody Plant - Standard Practices – Part 3 – Tree Support Systems

Table 1
Standards for Landscape

Priority	Author or Agency	Title
8	ANSI Z60.1	American Standard for Nursery Stock
9	NRCS	Pond Code 378, Visual Resource Design. Page 9
10	AASHTO	Roadside Design Guide Chapters 4, 5, 6 and 10
11	AASHTO	T88 and T194
12	SHA	Highway Hydraulic Division Stormwater Management Facility Safety Policy for Design
13	COMAR	Nutrient Management Law
14	SHA	Storm Water Management Safety Policy

2.2 REFERENCES

Use the references listed in Table 2 as supplementary guidelines for the design and construction of the Landscape & Aesthetics. These publications have no established order of precedence.

Table 2
References for Landscape

Author or Agency	Title
ANSI Z133.1	Safety Requirements for Pruning, Trimming, Repairing, Maintaining, and removing Trees, and for Cutting brush
Hortus Third	A Concise Dictionary of Plants Cultivated in the United States and Canada (L. H. Bailey Hortorium 1976)
AASHTO	A Guide for Transportation Landscape and Environmental Design
SHA	Rock Creek Option C through Winters Run Design Program Elements
AASHTO	Guide for the Development of Bicycle Facilities, AASHTO
DNR	Department of Natural Resources Article 5-103 – Maryland Reforestation Law; and Maryland Forest Conservation Act
SHA	Draft Aesthetics Design Guidelines for Section Engineers
SHA	Natural Environmental Technical Report for the ICC
SHA	Final Environmental Impact Statement for the ICC
SHA	Record of Decision for the ICC

3.0 LEAD LANDSCAPE ARCHITECT AND OTHER PERSONNEL REQUIREMENTS

This Project requires the Design-Builder to have an experienced landscape architectural design team to address, in a collaborative, multi-disciplinary approach, the functional and aesthetic needs of the Project, which includes the preparation and implementation of successful design responses to the commitments established for the Project. The landscape architectural team shall be led by a Maryland

Registered Landscape Architect (RLA) with more than 10 years of landscape architectural design experience related to highway corridor design and construction. The lead landscape architect shall have a working knowledge and experience with the implementation process of Context Sensitive Design/Solutions; be familiar with native vegetation of the Mid-Atlantic Region; be familiar with the requirements of the Maryland reforestation Law and the Maryland Forest Conservation Act; and be familiar with stormwater management/bioretenion planting.

4.0 PLANTING ZONES AND LANDSCAPE REQUIREMENTS

4.1 PLANTING ZONE TYPES

The Design-Builder shall prepare a Planting Plan for the Landscape and Reforestation Plantings, based on the RFP Landscape Concept Plans. The Landscape Concept Plans designate Planting Zone Types, location, and approximate square footage. The landscape planting concept shall be developed to reflect the use of native plants and to revegetate disturbed areas within the Project to the fullest extent possible. Large masses or groupings of trees and shrubs shall be created whenever possible to create naturalistic plantings that have continuity from one planting zone to the next. Seasonal interest shall be provided to the fullest extent possible. The Design-Builder shall be responsible for coordinating the Planting Plan for Landscape and Reforestation with all other elements of work to be performed under the Project, including but not limited to final grading, stormwater management best management practices (BMP) locations, highway clear zones and sight distances, storm drain and stormwater management BMP outfalls and cross culvert outfalls, utilities, signing/lighting and the location of earth reinforcement. Trees shall be offset a minimum of 40 feet from edge of travel lanes, 30 feet from bridge abutments, and minimum 10 feet from the community side of sound barriers. If the Design-Builder determines a conflict from one or more of these elements, the Design-Builder shall be responsible for modifying the concept plans, while still retaining the intent of the design. Areas used for stormwater management BMPs shall not be used for Landscape and Reforestation Plantings. Landscape plantings required as part of the stormwater management plans shall be coordinated with the landscape and reforestation plans to ensure a unified planting theme is created for the Project corridor. The Design-Builder shall furnish all specified seed and seed mixes according to the MDOT/SHA Standard Specifications for Construction and Materials 2001, Section 920.04.

The approved plant species, minimum acceptable sizes, and minimum spacing are listed below. Requests for substitution of other species shall be submitted in writing to the Administration.

4.1.1 Bridge Abutment/Embankment Areas (RFP Landscape Concept Plan Symbol "BR")

The Design-Builder shall prepare planting plans for the areas adjacent to the bridge abutments and embankment areas. The planting shall be integrated with the Landscape Concept Plan for the roadway corridor and compatible with the existing landscape of the adjacent land uses and surroundings. The Design-Builder shall employ a plant association consisting of shrubs only in all areas beyond 20 feet of bridge abutments and creating sight lines for motorists to view the bridge abutments. At the edges of this planting zone, trees shall be blended with the adjacent planting zone. Reference Figure 1.1.1.A – Bridge Alignment Sight Lines, in the Landscape Concept Plans. Plant selections shall be appropriate for the field environmental conditions of the planting site. The approved plant species, minimum acceptable sizes, and minimum spacings are listed below:

PLANT MATERIAL: Bridge Abutment/Embankment Areas – "BR"

Botanical Name	Common Name	Maximum Spacing	Minimum Size
Shade Trees Acer rubrum	Red Maple	25' OC	2-1/2" Cal. B&B

4.0 PLANTING ZONES AND LANDSCAPE REQUIREMENTS

4.1.1 Planting Zone Types

The Design-Builder shall prepare a Planting Plan for the Landscape and Reforestation Plantings, based on the RFP Landscape Concept Plans. The Landscape Concept Plans designate Planting Zone Types, location, and approximate square footage. The landscape planting concept shall be developed to reflect the use of native plants and to revegetate disturbed areas within the Project to the fullest extent possible. Large masses or groupings of trees and shrubs shall be created whenever possible to create naturalistic plantings that have continuity from one planting zone to the next. Seasonal interest shall be provided to the fullest extent possible. The Design-Builder shall be responsible for coordinating the Planting Plan for Landscape and Reforestation with all other elements of work to be performed under the Project, including but not limited to final grading, turf establishment, stormwater management best management practices (BMP) locations, highway clear zones and sight distances, storm drain and stormwater management BMP outfalls and cross culvert outfalls, utilities, signing/lighting, the location of earth reinforcement, and with regard to maintainability as indicated in the SHA Integrated Vegetation Management Manual for Maryland Highways.

Woody plant material offsets for planting zone types shall be in accordance with "Integrated Vegetation Management Manual for Maryland Highways" and the AASHTO "Roadside Design Guide." If the Design-Builder determines a conflict from one or more of these elements, the Design-Builder shall be responsible for modifying the concept plans, while still retaining the intent of the design. Areas used for stormwater management BMPs shall not be used for Landscape and Reforestation Plantings. Landscape plantings required as part of the stormwater management plans shall be coordinated with the landscape and reforestation plans to ensure a unified planting theme is created for the Project corridor. The Design-Builder shall furnish all specified seed and seed mixes according to the MDOT/SHA Standard Specifications for Construction and Materials 2001, Section 920.04.

The approved plant species, minimum acceptable sizes, and minimum spacing are listed below. The Contractor shall not plant non-native invasive plant species. The Design-Builder shall not use sericea lespedeza as part of the permanent seed mix additive C. Requests for substitution of other species shall be submitted in writing to the Administration.

4.1.2 Bridge Abutment/Embankment Areas (RFP Landscape Concept Plan Symbol "BR")

The Design-Builder shall prepare planting plans for the areas adjacent to the bridge abutments and embankment areas. The planting shall be integrated with the Landscape Concept Plan for the roadway corridor and compatible with the existing landscape of the adjacent land uses and surroundings. The Design-Builder shall employ a plant association in accordance with "Integrated Vegetation Management Manual for Maryland Highways" and the AASHTO "Roadside Design and for creating sight lines for motorists to view the bridge abutments. At the edges of this planting zone, trees shall be blended with the adjacent planting zone. Reference Figure 1.1.1.A – Bridge Alignment Sight Lines, in the Landscape Concept Plans. Plant selections shall be appropriate for the field environmental conditions of the planting site. The approved plant species, minimum acceptable sizes, and minimum spacings are listed below:

PLANT MATERIAL: Bridge Abutment/Embankment Areas – "BR"

Botanical Name	Common Name	Maximum Spacing	Minimum Size
Major Species (Shade Trees)			
Acer rubrum	Red Maple	25' OC	2" Cal. B&B/CG
Acer saccharum	Sugar Maple	25' OC	2" Cal. B&B/CG
Betula nigra	River Birch	20' OC	8' Ht. B&B/CG
Nyssa sylvatica	Black Gum	20' OC	2" Cal. B&B/CG
Platanus occidentalis	American Sycamore	25' OC	2" Cal. B&B/CG
Quercus alba	White Oak	25' OC	2" Cal. B&B/CG

Acer saccharum	Sugar Maple	25' OC	2-1/2" Ca. B&B
Betula nigra	River Birch	20' OC	8' Ht. B&B
Liquidambar styraciflua	Sweetgum	25' OC	2-1/2" Cal. B&B
Platanus occidentalis	American Sycamore	25' OC	2-1/2" Cal. B&B
Quercus coccinea	Scarlet Oak	25' OC	2-1/2" Cal. B&B
Quercus palustris	Pin Oak	25' OC	2-1/2" Cal. B&B
Quercus phellos	Willow Oak	25' OC	2-1/2" Cal. B&B
Flowering Trees			
Cercis canadensis	Eastern Redbud	15' OC	2" Cal. B&B
Chionanthus virginicus	White Fringetree	15' OC	6' Ht. B&B
Hamamelis virginiana	Witchhazel	15' OC	5' Ht. B&B
Magnolia virginiana	Sweetbay Magnolia	15' OC	6' Ht. B&B
Shrubs			
Physocarpus opulifolius	Common Ninebark	4' OC	30" Ht. Cont.
Rhus aromatica	Fragrant Sumac	3' OC	24" Ht. Cont.
Rosa carolina	Pasture Rose	3' OC	24" Spd. Cont.
Viburnum dentatum	Arrowwood Viburnum	4' OC	30" Ht. Cont.

Note: CG indicated Container Grown, B&B indicates Balled and Burlap, OC indicates On Center Spacing.

4.1.2 Mixed Use Path/Bike Trail Areas (RFP Landscape Concept Plan Symbol "BT")

The Design-Builder shall prepare Landscape Plans for the Planting adjacent to the bike trails shown on the RFP Plans. The planting shall be integrated with the landscaping concept chosen for the roadway corridor and compatible with the existing landscape of the adjacent land uses and surroundings. Plantings shall be arranged as accents and not as continuous groupings. Edges of plantings shall move in and out in relation to the trail. The density of planting shall be 100 stems per acre and shall include 1 tree every 3000 square feet and 1 shrub, arranged in groupings of 20 or more, every 400 square feet. Plantings shall be placed to promote the visibility and personal safety of trail users. Minimum safety clearances from the edge of the bike trail shall be in accordance with the Guide for the Development of Bicycle Facilities, AASHTO. Plant selections shall be appropriate for the field environment conditions of the planting site. The approved plant species, minimum acceptable sizes, and minimum spacings are listed below:

PLANT MATERIAL: Bike Trail Areas – "BT"

Botanical Name	Common Name	Maximum Spacing	Minimum Size
Flowering Trees			
Cercis canadensis	Redbud	15" OC	2" Cal. B&B
Shrubs			
Hypericum calycinum	St. Johnswort	18" OC	24" Ht. Cont.
Itea virginica	Sweetspire	3' OC	24" Ht. Cont.
Juniperus chinensis "Pfitziana"	Compact Pfitzer Juniper	4' OC	3' Ht. Cont.
Rosa "Knockout"	Knockout Rose	24" OC	2' Ht. Cont.

Note: CG indicated Container Grown, B&B indicates Balled and Burlap, OC indicates On Center Spacing.

4.1.3 Cashell Farm MOA (RFP Landscape Concept Plan Symbol “CF”)

The Cashell Farm shall receive the landscape treatments described in the MEMORANDUM OF AGREEMENT AMONG THE FEDERAL HIGHWAY ADMINISTRATION, THE MARYLAND STATE HISTORIC PRESERVATION OFFICER, THE MARYLAND TRANSPORTATION AUTHORITY AND THE MARYLAND STATE HIGHWAY ADMINISTRATION REGARDING THE INTERCOUNTY CONNECTOR PROJECT, Section I: Treatment of Architectural Historic Properties, Item A: J. H. Cashell Farm (M: 22-25). See the MOA planting plan for the required plant list.

4.1.4 Deckover Structure (RFP Landscape Concept Plan Symbol “DO”)

The Design-Builder shall prepare Landscape Plans for the areas identified as Deckover Structure on the RFP Plans according to the specifications entitled Rock Creek Option C through Winters Run – Design Program Elements included elsewhere in this RFP. The plantable area within the footprint of the deckover shall be planted with turf grasses only. The planting areas directly outside of the deckover footprint and up to the limit of disturbance shall be planted with informal groupings of screen plantings. The screen plantings shall mitigate the loss of plants from private property due to construction of the Deckover Structure. The density of the screen plantings shall be 1 shade tree for each 1500 square feet, 1 evergreen tree for each 2000 square feet, 1 ornamental tree for each 1500 square feet and 1 shrub for each 400 square feet. The planting shall be integrated with the Landscape Concept Plan for the roadway corridor and compatible with the existing landscape of the adjacent land uses and surroundings. Reference Figure 1.1.4.A – Deckover Concept Plan, in Landscape Concept Plans. Plant selections shall be appropriate for the field environmental conditions of the planting site. The approved plant species, minimum acceptable sizes, and minimum spacings are listed below:

PLANT MATERIAL: Deckover Structure – “DO”

Botanical Name	Common Name	Maximum Spacing	Minimum Size
Evergreen Trees			
<i>Pinus strobus</i>	Eastern White Pine	15' OC	8' Ht. B&B
<i>Pinus rigida</i>	Pitch Pine	15' OC	8' Ht. B&B
<i>Juniperus virginiana</i>	Red Cedar	8' OC	8' Ht. B&B
<i>Ilex opaca</i>	American Holly	15' OC	5' Ht. B&B
Shade Trees			
<i>Acer rubrum</i>	Red Maple	25' OC	2-1/2" Cal. B&B
<i>Betula nigra</i>	River Birch	20' OC	8' Ht. B&B
<i>Quercus palustris</i>	Pin Oak	25' OC	2-1/2" Cal. B&B
<i>Quercus rubra</i>	Red Oak	25' OC	2-1/2" Cal. B&B
Shrubs			
<i>Amelanchier canadensis</i>	Serviceberry	15' OC	8' Ht. B&B
<i>Cornus sericea</i>	Redtwig Dogwood	5' OC	3' Ht. CG
<i>Ilex glabra</i>	Inkberry Holly	4' OC	3' Ht. CG
<i>Ilex verticillata</i>	Winterberry	5' OC	3' Ht. CG
(OED approved sp.)			
(Provide adequate # of male plants)			
<i>Lonicera fragrantissima</i>	Fragrant Honeysuckle	5' OC	3' Ht. CG
<i>Myrica pensylvanica</i>	Northern Bayberry	6' OC	3-1/2' Ht. CG
<i>Viburnum acerfolium</i>	Mapleleaf Viburnum	6' OC	3' Ht. CG
<i>Viburnum dentatum</i>	Arrowwood Viburnum	6' OC	3' Ht. CG

Viburnum prunifolium Blackhaw Viburnum 6' OC 3' Ht. CG

Note: CG indicates Container Grown, B&B indicates Balled and Burlap, OC indicates On Center Spacing.

4.1.5 Forest Edge (RFP Landscape Concept Plan Symbol “FE”)

The Design-Builder shall prepare Landscape Plans for the areas identified as forest edge plantings. This planting zone occurs in areas where the roadway construction requires that a portion of the existing forest be removed, exposing plant material that was once “inside” the forest. A new “edge” shall be replanted using plant material and will include shrubs, understory trees, and overstory tree species. The Design-Builder shall employ this planting association at the edges of clearing of existing forest, as indicated on the conceptual Landscape Plans. The plant association shall be designed as a band between the forest edge and the safety/clear zone limits, in accordance with the Administration’s Slope Management Standards in the Integrated Vegetation Management Manual for Maryland Highways and the AASHTO Roadside Design Guide. The plantings shall, at a minimum, consist of random mix of tree and shrub groupings. Density of plantings shall be 1 shade tree for each 1,500 square feet, 1 evergreen tree for each 3,000 square feet, 1 flowering tree for each 750 square feet, and 1 shrub for each 400 square feet. A minimum of 3 tree species and a minimum of 3 shrub species shall be selected for use. Plant selections shall be appropriate for the field environmental conditions of the planting site and plantings shall blend with adjacent zones. The approved plant species, minimum acceptable sizes, and minimum spacings are listed below:

PLANT MATERIAL: Forest Edge – “FE”

Botanical Name	Common Name	Maximum Spacing	Minimum Size
Shade Trees			
Acer rubrum	Red Maple	30' OC	2" Cal.B&B
Acer saccharinum	Silver Maple	30' OC	2" Cal.B&B
Betula lenta	Sweet (Black) Birch	30' OC	2" Cal.B&B
Betula nigra	River Birch	20' OC	6' Ht. B&B
Cladrastis kentukea	American Yellowwood	30' OC	2" Cal.B&B
Fagus grandifolia	American Beech	30' OC	1 1/2" Cal.B&B
Liriodendron tulipifera	Tuliptree	30' OC	2" Cal.B&B
Liquidambar styraciflua	Sweetgum	30' OC	2" Cal. B&B
Nyssa sylvatica	Blackgum	30' OC	2" Cal.B&B
Platanus occidentalis	American Sycamore	30' OC	2" Cal.B&B
Quercus alba	White Oak	30' OC	2" Cal.B&B
Quercus palustris	Pin Oak	30' OC	2" Cal.B&B
Quercus phellos	Willow Oak	30' OC	2" Cal.B&B
Quercus rubra	Red Oak	30' OC	2" Cal. B&B
Evergreen Trees			
Ilex opaca (approved varieties)	American Holly	15' OC	5' Height, CG
Juniperus virginiana	Eastern Red Cedar	10' OC	5' Height, CG
Picea abies	Norway Spruce	15' OC	5' Height, CG
Pinus strobus	White Pine	15' OC	5' Height, CG
Flowering Trees			
Amelanchier arborea	Downy Serviceberry	15' OC	6' Ht. B&B
Amelanchier canadensis	Serviceberry	15' OC	2" Cal.B&B
Cercis canadensis	Eastern Redbud	15' OC	6' Ht. B&B

Minor Species (Evergreen Trees)

Ilex opaca	American Holly	15' OC	5' Height, CG
(OED approved species, provide adequate # of male plants)			
Juniperus virginiana	Eastern Red Cedar	10' OC	5' Height, CG
Pinus strobus	White Pine	15' OC	5' Height, CG

Minor Species (Flowering Trees)

Amelanchier arborea	Downy Serviceberry	15' OC	6' Ht. B&B/CG
Cercis canadensis	Eastern Redbud	15' OC	6' Ht. B&B/CG
Cornus florida	Flowering Dogwood	15' OC	2" Cal. B&B/CG
Cornus 'Rutlan'	Hybrid Dogwood	20' OC	2" Cal. B&B/CG
Crataegus viridis 'Winter King'	Winter King Hawthorn	20' OC	1-1/2" Cal. B&B/CG
Halesia carolina	Carolina Silverbell	15' OC	5' Ht. CG/CG
Hamamelis virginiana	Common Witchhazel	15' OC	6' Ht. B&B/CG

Minor Species (Shrubs)

Aronia arbutifolia	Red Chokeberry	5' OC	3' Ht. CG
Cornus amomum	Silky Dogwood	5' OC	3' Ht. CG
Cornus sericea	Redtwig Dogwood	5' OC	3' Ht. CG
Ilex verticillata	Winterberry	5' OC	3' Ht. CG
(OED approved species, provide adequate # of male plants) Juniperus spp. (OED appr. sp.) Juniper			
	15" Spread, CG		
Physocarpus opulifolius	Eastern Ninebark	5' OC	3' Ht. CG
Sassafras albidum	Sassafras	10' OC	5' Ht. CG
Rhus copallina	Shining Sumac	5' OC	3' Ht. CG
Rhus glabra	Smooth Sumac	5' OC	3' Ht. CG
Rhus typhina	Staghorn Sumac	5' OC	3' Ht. CG
Viburnum acerifolium	Mapleleaf Viburnum	6' OC	3' Ht. CG
Viburnum dentatum	Arrowwood Viburnum	6' OC	3' Ht. CG
Viburnum pragensense	Prague Viburnum	5' OC	3' Ht. B&B
Viburnum prunifolium	Blackhaw Viburnum	6' OC	3' Ht. CG

Note: CG indicates Container Grown, B&B indicates Balled and Burlapped, OC indicates On Center Spacing.

4.1.7 Interchanges/Gateways Areas (RFP Landscape Concept Plan Symbol "IG")

The Design-Builder shall prepare Landscape Plans for the Interchanges/Gateways identified on the Landscape Concept plans. The planting shall be integrated with the landscaping concept chosen for the roadway corridor. The intent is to use the Interchanges/Gateways to create gateways into the adjacent communities and the Intercounty Connector. The planting concept for all of the Interchanges/Gateways shall incorporate shade trees, evergreen trees, flowering trees, a mix of evergreen and deciduous shrubs, ornamental grasses, perennials, and bulbs from the approved planting list. In areas of the individual gateways and when developed design concept do not warrant the use of herbaceous plant material, one shade tree shall be substituted for each eight perennials or ornamental grasses and for each 15 bulbs. Quantity of plantings shall be 1 shade tree for each 1,000 square feet, 1 evergreen tree for each 2,000 square feet, 1 flowering tree for each 1,000 square feet, and 1 shrub for each 400 square feet, 1 perennial for each 200 square feet, 1 ornamental grass for each 200 square feet, and 1 bulb for each 100 square feet. A minimum of 3 tree species and a minimum of 3 shrub species shall be selected for use. The Design-Builder shall employ this plant association as indicated on the Landscape Concept Plans. The plantings

environmental conditions of the planting site. The approved plant species, minimum acceptable sizes, and minimum spacings are listed below:

PLANT MATERIAL: Interchanges/Gateways – “IG”

Botanical Name	Common Name	Maximum Spacing	Minimum Size
Shade Trees			
<i>Acer rubrum</i> ‘Armstrong’	Armstrong Maple	25’ OC	2-1/2” Cal. B&B
<i>Acer rubrum</i> ‘Bowhall’	Bowhall Maple	25’ OC	2-1/2” Cal. B&B
<i>Acer rubrum</i> ‘Red Sunset’	Red Sunset Maple	25’ OC	2-1/2” Cal. B&B
<i>Acer saccharum</i>	Sugar Maple	25’ OC	2-1/2” Cal B&B
<i>Betula nigra</i>	River Birch	20’ OC	8’ Ht B&B.
<i>Cladrastis kentucea</i>	Yellowwood	25’ OC	2-1/2” Cal. B&B
<i>Ginkgo biloba</i> ‘Autumn Gold’	Maidenhair Tree (Male only)	25’ OC	2-1/2” Cal. B&B
<i>Liquidambar styraciflua</i>	Sweet Gum	25’ OC	2-1/2” Cal. B&B
<i>Metasequoia glyptostroboides</i>	Dawn Redwood	25’ OC	8’ Ht. B&B
<i>Platanus x acerifolia</i> ‘Bloodgood’	London Planetree	25’ OC	2-1/2” Cal. B&B
<i>Platanus occidentalis</i>	American Sycamore	25’ OC	2-1/2” Cal. B&B
<i>Quercus coccinea</i>	Scarlet Oak	25’ OC	2-1/2” Cal. B&B
<i>Quercus palustris</i>	Pin Oak	25’ OC	2-1/2” Cal. B&B
<i>Quercus phellos</i>	Willow Oak	25’ OC	2-1/2” Cal. B&B
<i>Quercus rubra</i>	Red Oak	25’ OC	2-1/2” Cal. B&B
<i>Taxodium distichum</i>	Baldcypress	25’ OC	8’ Ht. B&B
Evergreen Trees			
<i>Ilex opaca</i> (approved varieties)	American Holly	15’ OC	5’ Ht. CG
<i>Juniperus virginiana</i>	Eastern Red Cedar	10’ OC	5’ Ht. CG
<i>Picea abies</i>	Norway Spruce	15’ OC	5’ Ht. CG
<i>Pinus strobus</i>	Eastern White Pine	20’ OC	10’ Ht. CG
<i>Pinus virginiana</i>	Virginia Pine	15’ OC	5’ Ht. CG
Flowering Trees			
<i>Amelchier x grandiflora</i>	Apple Serviceberry	15’ OC	2” Cal. B&B
<i>Cercis canadensis</i>	Eastern Redbud	15’ OC	2” Cal. B&B
<i>Chionanthus virginicus</i>	White Fringetree	15’ OC	6’ Ht. B&B
<i>Chionanthus retusus</i>	Chinese Fringetree	10’ OC	5’ Ht. B&B
<i>Cornus kousa</i>	Kousa Dogwood	15’ OC	2” Cal. B&B
<i>Cornus x Rutcan</i>	Constellation Dogwood	15’ OC	2” Cal. B&B
<i>Crataegus phaenopyrum</i>	Washington Hawthorn	20’ OC	2” Cal. B&B
<i>Hamamelis virginiana</i>	Witchhazel	15’ OC	5’ Ht. B&B
<i>Magnolia virginiana</i>	Sweetbay Magnolia	15’ OC	6’ Ht. B&B
<i>Malus sp</i> (OED approved sp.)	Crabapple	20’ OC	2” Cal. B&B
<i>Prunus sp</i> (OED approved sp.)	Cherry	20’ OC	2” Cal. B&B
Shrubs			
<i>Aesculus pavviflora</i>	Bottlebrush Buckeye	5’ OC	3’ Ht. CG
<i>Aesculus pavia</i>	Red Buckeye	5’ OC	3’ Ht. CG
<i>Fothergilla gardeni</i>	Dwarf Fothergilla	3’ OC	2’ spread CG
<i>Fothergilla major</i>	Large Fothergilla	5’ OC	2-1/2” Ht. CG
<i>Ilex glabra</i>	Inkberry Holly	5’ OC	3’ Ht. CG

Ilex verticillata (OED approved sp.) (Provide adequate # of male plants)	Winterberry	5' OC	3' Ht. Cont.
Juniperus chinensis hybrids	Chinese Juniper	4' OC	2-1/2' Spread CG
Juniperus confert hybrids	Shore Juniper	3' OC	2' Spread CG
Spiraea sp. (OED approved sp.)	Spiraea	4' OC	2' Ht. CG
Rhus aromatica	Fragrant Sumac	3' OC	2' Ht. CG
Rosa 'Knockout'	Knockout Rose	3' OC	2' Spd. CG
Viburnum carlesii	Koreanspice Viburnum	5' OC	3-1/2' Height, CG
Viburnum dentatum	Arrowood Viburnum	5' OC	2-1/2' Ht. CG
Viburnum pragensis	Prague Viburnum	6' OC	4' Ht. CG
Perennials and Grasses			
Andropogon scoparius	Little Bluestem	24" OC	1 Qt. CG
Asclepias tuberosa	Butterfly Weed	18" OC	1 Qt. CG
Aster laevis	Smooth Blue Aster	18" OC	1 Qt. CG
Aster novae-angliae	New England Aster	18" OC	1 Qt. CG
Baptisia australis	False Blue Indigo	3' OC	1 Gal. CG
Boltonia asteroides	False Aster	18" OC	1 Gal. CG
Chelone glabra	Turtlehead	18" OC	1 Qt. CG
Echinacea purpurea	Purple Coneflower	24" OC	1 Qt. CG
Heliopsis helianthoides	False Sunflower	18" OC	1 Qt. CG
Hibiscus sp. 'Lord Baltimore'	Rose Mallow Hibiscus	3' OC	1 Gal. CG
Liatris spicata	Gayfeather	3' OC	1 Gal. CG
Narcissus sp.	Daffodil species	12" OC	Top Size Bulb
Planted 3 per hole			
Panicum virgatum	Switchgrass	3' OC	1 Gal. CG
Penstemon digitalis	Beardtongue	2' OC	1 Qt. CG
Perovskia atriplicifolia	Russian Sage	24" OC	1 Qt. CG
Phlox paniculata	Summer Phlox	24" OC	1 Qt. CG
Solidago nemoralis	Goldenrod	24" OC	1 Qt. CG

Note: CG indicates Container Grown, B&B indicates Balled and Burlap, OC indicates On Center Spacing

4.1.7 Median Areas – 50 ft. Median Width (RFP Landscape Concept Plan Symbol "M50")

The Design-Builder shall prepare Landscape Plans for the 50 foot width median areas shown on the Landscape Concept Plans. Medians with a minimum 50 foot width shall be planted with predominantly turf grasses and in situations where warranted, shrub beds with a minimum of 75 shrubs per grouping to provide screening and reduce headlight glare. Plant materials shall be placed to avoid conflicts with median SWM facilities, guardrail, signage and highway appurtenances. Shrubs and grasses shall not be installed above underground SWM facilities. Plant selections shall be appropriate for the field conditions of the planting site. The approved plant species, minimum acceptable sizes, and minimum spacings are listed below:

PLANT MATERIAL: Median Areas – 50' Median Width – M50

Botanical Name	Common Name	Maximum Spacing	Minimum Size
Shrubs			
Baccharis halimifolia	Groundsel-bush	6' OC	3' Ht. CG
Cornus sericea	Redosier Dogwood	5' OC	3' Ht. CG

Ilex glabra	Inkberry	6' OC	3' Ht. CG
Ilex verticillata	Winterberry	5' OC	3' Ht. CG
(OED approved sp.) (Provide adequate # of male plants)			
Ligustrum amurense	Amur Privet	6' OC	3' Ht. CG
Lindera benzoin	Spicebush	6' OC	3.5' Ht. CG
Myrica pensylvanica	Bayberry	6' OC	3.5' Ht. CG
Rhus glabra	Smooth Sumac	6' OC	3.5' Ht. CG
Viburnum dentatum	Arrowood Viburnum	6' OC	3' Ht. CG
Viburnum prunifolium	Blackhaw Viburnum	6' OC	3.5' Ht. CG

Grasses

Andropogon gerardii	Big Bluestem	3' OC	1 Gal. CG
Andropogon scoparius	Little Bluestem	3' OC	1 Gal. CG
Andropogon virginicus	Broomsedge	24" OC	1 Gal. CG
Carex stricta	Tussock Sedge	24" OC	1 Gal. CG
Panicum virgatum	Switch Grass	3' OC	1 Gal. CG

Note: CG indicates Container Grown, B&B indicates Balled and Burlap, OC indicates On Center Spacing.

4.1.8 Roadside Screening Areas (RFP Landscape Concept Plan Symbol “RB”)

The Design-Builder shall identify areas that require screening and shall prepare Landscape Plans. Areas to be screened are where the roadway is adjacent to residential or institutional types of land uses. The goal is to create an attractive landscape screen adjacent to sensitive areas. The planting shall be integrated with the landscaping concept chosen for the roadway corridor. The Design-Builder shall employ this planting association between the roadway and adjacent land uses, as indicated on the Landscape Concept Plans. The plant association shall be designed for maximum screening between the roadway and adjacent land use. Evergreen materials shall be included in the mix, and may predominate. The plantings shall, at a minimum, consist of a random mix of tree and shrub groupings. Shrubs shall be planted in continuous mulched beds. Mulched beds shall be extended to include individual trees when those trees are within 3 feet of the mulched bed boundary. Density of plantings shall be 1 major deciduous tree for each 1,500 square feet, 1 flowering tree for each 1,500 square feet, 1 evergreen tree for each 1,000 square feet, and 1 shrub for each 400 square feet. A minimum of 5 Shade Tree species, a minimum of 3 Flowering Tree species, a minimum of 3 Evergreen Tree species and a minimum of 3 Shrub species shall be selected for use and per contiguous planting zone area illustrated on the Landscape Concept Plans. The edges of the planting zone shall blend with the adjacent planting zone. Plant selections shall be appropriate for the field environmental conditions of the planting site. The approved plant species, minimum acceptable sizes, and minimum spacings are listed below:

PLANT MATERIAL: Roadside Screening – “RB”

Botanical Name	Common Name	Maximum Spacing	Minimum Size
Shade Trees			
Acer rubrum	Red Maple	25' OC	2" Cal. B&B
Betula lenta	Sweet (Black) Birch	25' OC	2" Cal. B&B
Betula nigra	River Birch	20' OC	8' Ht. B&B
Carpinus caroliniana	American Hornbeam	20' OC	2' Cal. B&B
Celtis occidentalis	Common Hackberry	25' OC	2" Cal. B&B
Cladrastis kentukea	American Yellowwood	25' OC	2" Cal. B&B
Liquidambar styraciflua	Sweetgum	25' OC	2" Cal. B&B

Liriodendron tulipifera	Tulip Poplar	25' OC	2" Cal. B&B
Nyssa sylvatica	Black Gum	25' OC	2" Cal. B&B
Platanus occidentalis	American Sycamore	25' OC	2" Cal. B&B
Quercus alba	White Oak	25' OC	2" Cal. B&B
Quercus coccinea	Scarlet Oak	25' OC	2" Cal. B&B
Quercus palustris	Pin Oak	25' OC	2" Cal. B&B
Quercus phellos	Willow Oak	25' OC	2" Cal. B&B
Quercus prinus	Chestnut Oak	25' OC	2" Cal. B&B
Quercus rubra	Red Oak	25' OC	2" Cal. B&B
Sassafras albidum	Sassafras	15' OC	2" Cal. B&B
Tilia americana	Basswood	25' OC	2" Cal. B&B
 Flowering Trees			
Amelanchier arborea	Downy Serviceberry	15' OC	6' Ht. B&B
Amelanchier canadensis	Shadblow Serviceberry	15' OC	6' Ht. B&B
Amelanchier laevis	Allegheny Serviceberry	15' OC	6' Ht. B&B
Cercis canadensis	Eastern Redbud	15' OC	2" Cal. B&B
Chionanthus virginicus	White Fringetree	15' OC	6' Ht. B&B
Crataegus viridis Winter King'	Winter King Hawthorn	15' OC	2" Cal. B&B
Crataegus crus-galli	Cockspur Hawthorn	15' OC	2 Cal. B&B
Hamamelis virginiana	Witchhazel	15' OC	5' Ht. B&B
Magnolia virginiana	Sweetbay Magnolia	15' OC	6' Ht. B&B
 Evergreen Trees			
Cupressocyparis leylandii	Leyland Cypress	10' OC	6' Ht. B&B
Ilex opaca (approved varieties)	American Holly	15' OC	5' Ht. B&B
Juniperus virginiana	Eastern Red Cedar	10' OC	8' Ht. B&B
Picea abies	Norway Spruce	20' OC	8' Ht. B&B
Pinus strobus	Eastern White Pine	20' OC	8' Ht. B&B
 Deciduous Shrubs			
Aesculus parvifolia	Bottlebrush Buckeye	5' OC	4' Ht. CG
Aronia arbutifolia	Red Chokeberry	5' OC	3.5' Ht. CG
Calycanthus floridus	Carolina Allspice	5' OC	3.5' Ht. CG
Cornus racemosa	Gray Dogwood	5' OC	3' Ht. CG
Cornus sericea	Redtwig Dogwood	5' OC	3' Ht. CG
Ilex verticillata	Winterberry	5' OC	3' Ht. CG
(OED approved sp.)			
Myrica cerifera	Southern Bayberry	5' OC	3.5' Ht. CG
Myrica pensylvanica	Northern Bayberry	65 OC	3.5' Ht. CG
Lindera benzoin	Spicebush	5' OC	3' Ht. CG
Physocarpus opulifolius	Eastern Ninebark	3' OC	2-1/2' Ht. CG
Prunus maritima	Beach Plum	5' OC	3.5' Ht. CG
Rhododendron maximum	Rosebay Rhododendron	6' OC	3' Ht. CG
Rhus aromatica	Fragrant Sumac	5' OC	3' Ht. CG
Rhus copallina	Shining Sumac	5' OC	3' Ht. CG
Rhus glabra	Smooth Sumac	5' OC	3' Ht. CG
Rhus typhina	Staghorn Sumac	5' OC	3' Ht. CG
Vaccinium corymbosum	Highbush Blueberry	5' OC	2-1/2" Ht. CG
Viburnum acerifolium	Mapleleaf Viburnum	5' OC	3' Ht. CG
Viburnum dentatum	Arrowood Viburnum	6' OC	3' Ht. CG

Spacing.

4.1.10 Re-forestation Areas (RFP Landscape Concept Plan Symbol "RV")

In the design and execution of reforestation plantings, the Design-Builder shall comply with the requirements of the Reforestation Law, as specified in the Environmental Performance Specification. Project reforestation plantings shall be within right-of-way limits, easements, limits of disturbance and/or parcels acquired by the Administration. Reforestation plantings shall be accommodated in all areas within the Project corridor in which non-native invasive species shall be controlled in accordance with the SHA Record of Decision for the ICC commitment #158. In designing and executing the reforestation plantings, the Design-Builder shall employ a method of "random spacing" (Reference Figure 4.1.11.B-Naturalistic Drifts of Trees and Shrubs on the Landscape Concept Plans) and a density of 200 stems per acre. 70% of the species shall be Major species, and 30% shall be Minor species, chosen from the list of approved species, below. A minimum of 5 Deciduous Tree species shall be selected for the Major species, and a minimum of 3 species shall be selected for the Minor Tree species. A minimum of 4 plant genera shall be included in the plant selection. In addition to the reforestation-sized planting stock, each reforestation area shall contain, interspersed randomly among the reforestation stock, trees chosen from the Major Deciduous Tree List, which are a minimum of 2.5 inches in caliper, at a planting density of 20 trees per acre. The Design-Builder shall install tree guards/shelters around smaller trees to protect from animals. Plant selections shall be appropriate for the field environmental conditions of the planting site. The approved plant species, minimum acceptable sizes, and minimum spacing are listed below:

PLANT MATERIAL: Reforestation- "RV"

Botanical Name	Common Name	Maximum Spacing	Minimum Size
Major Species (Deciduous Shade Trees)			
<i>Acer rubrum</i>	Red Maple	16' OC	1 1/2" Cal. B&B/CG
<i>Betula nigra</i>	River Birch	16' OC	7' Ht. B&B/CG
<i>Carpinus caroliniana</i>	American Hornbeam	16' OC	6' Ht. B&B/CG
<i>Carya ovata</i>	Shagbark Hickory	16' OC	5' Ht. CG
<i>Carya tomentosa</i>	Mockernut Hickory	16' OC	5' Ht. B&B/CG
<i>Fagus grandifolia</i>	American Beech	16' OC	5' Ht. B&B/CG
<i>Liriodendron tulipifera</i>	Yellow Poplar	16' OC	2" Cal. B&B
<i>Populus deltoides</i>	Cottonwood	16' OC	5' Ht. B&B/CG
<i>Platanus occidentalis</i>	American Sycamore	16' OC	1 1/2" Cal. B&B/CG
<i>Quercus alba</i>	White Oak	16' OC	1 1/2" Cal. B&B/CG
<i>Quercus palustris</i>	Pin Oak	16' OC	1 1/2" Cal. B&B/CG
<i>Quercus rubra</i>	Northern Red Oak	16' OC	1 1/2" Cal. B&B/CG
<i>Quercus velutina</i>	Black Oak	16' OC	5' Ht. B&B/CG
<i>Tilia americana</i>	Basswood	16' OC	1 1/2" Cal. B&B/CG
Minor Species (Flowering Deciduous Trees)			
<i>Amelanchier arborea</i>	Downy Serviceberry	15' OC	6' Ht. CG
<i>Amelanchier canadensis</i>	Shadblow Serviceberry	15' OC	6' Ht. CG
<i>Cercis canadensis</i>	Eastern Redbud	15' OC	6' Ht. CG
<i>Chionanthus virginicus</i>	White Fringetree	15' OC	6' Ht. CG
<i>Cornus florida</i>	Flowering Dogwood	15' OC	6' Ht. CG
<i>Hamamelis virginiana</i>	Common Witchhazel	15' OC	6' Ht. CG
<i>Prunus serotina</i>	Black Cherry	15' OC	6' Ht. CG
<i>Rhus typhina</i>	Staghorn Sumac	6' OC	3' Ht. CG
<i>Sassafras albidum</i>	Sassafras	15' OC	6' Ht. CG

<i>Cercis canadensis</i>	Eastern Redbud	15' OC	6' Ht. CG
<i>Chionanthus virginicus</i>	White Fringetree	15' OC	6' Ht. CG
<i>Cornus florida</i>	Flowering Dogwood	15' OC	6' Ht. CG
<i>Hamamelis virginiana</i>	Common Witchhazel	15' OC	6' Ht. CG
<i>Magnolia virginiana</i>	Sweetbay Magnolia	15' OC	6' Ht. CG
<i>Sassafras albidum</i>	Sassafras	15' OC	6' Ht. CG
Understory Species (Evergreen Trees)			
<i>Ilex opaca</i> (approved varieties)	American Holly	15' OC	4' Ht. CG
<i>Juniperus virginiana</i>	Eastern Red Cedar	15' OC	5' Ht. CG
<i>Pinus taeda</i>	Loblolly Pine	15' OC	5' Ht. CG
<i>Pinus strobus</i>	White Pine	15' OC	5' Ht. CG
Understory Species (Shrubs)			
<i>Aronia arbutifolia</i>	Red Chokeberry	6' OC	3' Ht. CG
<i>Cornus amomum</i>	Silky Dogwood	5' OC	3' Ht. CG
<i>Cornus racemosa</i>	Gray Dogwood	5' OC	3' Ht. CG
<i>Cornus sericea</i>	Redtwig Dogwood	5' OC	3' Ht. CG
<i>Ilex verticillata</i>	Winterberry	5' OC	3' Ht. CG
(Provide adequate # of male plants)			
<i>Itea virginica</i>	Virginia Sweetspire	4' OC	3' Ht. CG
<i>Lindera benzoin</i>	Spicebush	5' OC	3' Ht. CG
<i>Rhus aromatica</i>	Fragrant Sumac	5' OC	3' Ht. CG
<i>Rhus glabra</i>	Smooth Sumac	6' OC	3' Ht. CG
<i>Rhus typhina</i>	Staghorn Sumac	6' OC	3' Ht. CG
<i>Physocarpus opulifolius</i>	Eastern Ninebark	6' OC	3' Ht. CG
<i>Viburnum acerifolium</i>	Mapleleaf Viburnum	5' OC	3' Ht. CG
<i>Viburnum dentatum</i>	Southern Arrowwood	5' OC	3' Ht. CG
<i>Viburnum lentago</i>	Nannyberry Viburnum	6' OC	3' Ht. CG
<i>Viburnum prunifolium</i>	Blackhaw Viburnum	6' OC	3' Ht. CG

Note: CG indicated Container Grown, B&B indicates Balled and Burlap, OC indicates On Center Spacing.

4.1.10 Street Tree (RFP Landscape Concept Plan Symbol "RS")

The intent is to provide street trees on roadways that intersect the Intercounty Connector within the limits of disturbance. All street tree plantings shall be in accordance with requirements of the property owner and local jurisdiction. It is the responsibility of the Design-Builder to determine street tree locations based on existing and proposed signs, utility locations, and adjacent land uses. The Design-Builder shall employ this planting association along the roadside, as indicated on the conceptual Landscape Plans. The Design-Builder shall submit a site analysis plan indicating the planting opportunities for this category. The Design-Builder shall maximize planting whenever possible. The plantings shall, at a minimum, consist of a single row of shade trees, planted in long groups of the same genus. Areas of separation between groups of plants shall serve as the starting point for changing to a different plant genus. Density of plantings shall be as indicated below and as presented to the Administration for consultation and written comment. Plant selections shall be appropriate for the field environmental conditions of the planting site. The design shall maintain sight lines at all times. The approved plant species, minimum acceptable sizes, and maximum spacings are listed below:

PLANT MATERIAL: Street Tree – "RS"

Botanical Name	Common Name	Maximum Spacing	Minimum Size
----------------	-------------	-----------------	--------------

Shade Trees

Acer rubrum ‘Red Sunset’	Red Sunset Maple	30’ OC	2-1/2” Cal. B&B
Acer rubrum ‘Bowhall’	Bowhall Maple	30’ OC	2-1/2” Cal. B&B
Ginkgo biloba ‘Autumn Gold’ (Male only)	Maidenhair Tree	30’ OC	2-1/2” Cal. B&B
Metasequoia glyptostroboides	Dawn Redwood	30’ OC	2-1/2” Cal. B&B
Platanus x acerfolia ‘Bloodgood’	London Planetree	30’ OC	2-1/2” Cal. B&B
Quercus phellos	Willow Oak	30’ OC	2-1/2” Cal. B&B
Quercus rubra	Red Oak	30’ OC	2-1/2” Cal. B&B
Ulmus parvifolia	Paperbark Elm	30’ OC	2-1/2” Cal. B&B
Tilia tomentosa	Silver Linden	30’ OC	2-1/2” Cal. B&B
Ulmus parvifolia cultivars	Chinese Elm Cultivars	30’ OC	2-1/2” Cal. B&B

Flowering Trees

Amelanchier laevis	Allegheny Serviceberry	20’ OC	8’ Ht. B&B
Craetegus crusgalli	Hawthorn	20’ OC	8’ Ht. B&B
Lagerstroemia indica ‘Natchez’	Natchez Craemyrtle	20’ OC	8’ Ht. B&B
Malus sp.	Crabapple	20’ OC	2” Cal. B&B
Prunus x Okame	Okame Cherry Tree	20’ OC	2” Cal. B&B

Deciduous Trees Acceptable for Under Overhead Utilities

Acer campestre	Hedge Maple	20’ OC	2-1/2” Cal. B&B
Acer ginnala ‘Flame’	Flame Amur Maple	20’ OC	2-1/2” Cal. B&B
Amelanchier laevis ‘Majestic’	Majestic Serviceberry	20’ OC	2-1/2” Cal. B&B
Cladrastis kentukea	Yellowwood	20’ OC	2-1/2” Cal. B&B
Cornus kousa	Kousa Dogwood	20’ OC	2-1/2” Cal. B&B
Crateagus viridis ‘Winter King’	Winter King Hawthorn	20’ OC	2-1/2” Cal. B&B

Note: CG indicated Container Grown, B&B indicates Balled and Burlap, OC indicates On Center Spacing.

4.1.11 Storm Water Management Areas (RFP Landscape Concept Plan Symbol “SWM”)

Planting plans shall be prepared for stormwater management (SWM) facilities and shall be integrated with the Landscape Concept Plan for the roadway corridor and compatible with the existing landscape of the adjacent land uses and surroundings. Plant selections at SWM areas shall be as appropriate for each facility type.

The goal of planting at SWM facilities is to provide maximum environmental value (water quality, wildlife, bio-diversity) while providing low maintenance, native landscapes within curvilinear-shaped SWM facilities. In order to create a highway corridor that maximizes Maryland’s native beauty, fall color shall be maximized in the choice of native trees and shrubs, and the winter structure shall be maximized in the choice of native grasses and forbs.

See the Drainage Performance Specification for engineering requirements at SWM facilities.

4.1.12 SWM Minimum Planting Requirements

Planting configurations for native SWM landscape schemes shall not be uniform, static patterns such as grids or lines. Instead, the planting configurations shall mimic natural colonization in natural plant communities. A relaxed sense of order shall be provided while avoiding the appearance of plants randomly dotted about the terrain. The arrangement of species in planting zones that require uniform

cover of plant material (e.g., emergent, floating aquatic or shallow marsh areas) shall be arranged in homogenous groupings that intermingle with groupings of other species.

Reference Figure 4.1.11.A – Natural Plant Placement, in Landscape Concept Plans. Each shape and size represents a different species. The placement of each species relative to the others involves intermingling while forming somewhat homogenous colonies at the same time.

The arrangement of species in plant zones that require loose arrangements of individual plants (e.g., perimeter shade zone) shall be placed in naturalistic drifts of same species intermingled with individual species providing ornamental interest.

Reference 4.1.11.B – Naturalistic Drifts of Trees and Shrubs, in Landscape Concept Plans. Groups of plants are placed in loose drifts interspersed with individual plants of different species that provide ornamental interest. Drifts flow parallel to the contours.

4.1.13 Naturalistic Drifts of Trees and Shrubs

The Design shall adhere to the following list of minimum planting requirements. A concept sketch of the planting zones follows each facility type. Lists of approved species for each facility type and planting zone are provided in the next section.

The table below for SWM ponds and wetlands, Table 4.1A, lists all the possible planting zones for these types of SWM facilities. The design shall provide planting according to the zones required by the particular facility being designed. Ponds shall have aquatic benches that are emergent & floating aquatic zones; water depths greater than 48 inches that are submerged aquatic zones and storm elevations for up to the 10-year storm that are frequently fluctuating zones. Wetlands shall have micro-pools or deep pools that are submerged aquatic zones, shallow wetland areas that are emergent & floating aquatic zones and water fluctuations up to the 10 year storm that are frequently fluctuating zones. Both SWM ponds and wetlands are required to have the perimeter shade planting, which covers the emergent zone through the frequently fluctuating zone.

**Table 4.1A
 Minimum Planting Requirements at SWM Ponds
 and Wetland Hydrologic Zones**

Min. Quantity/ Placement Considerations	Min. Size/Rate	Root Condition
Submerged Aquatic Zone (48 in. or greater depth permanent water)		
1 plant per 9 cu. ft. of water volume for water depths 48 in. or deeper. Min. 2 species with no one species being greater than 60% of the total plants in this zone	8 in. ht./length	Bare root
Emergent & Floating Aquatic Zone (up to 18 in. depth permanent water)		
24 in. centers max. spacing (2.9 plants per 10 sq. ft.) Min. 3 species shall be provided with no one species being greater than 50% of the total plants in this zone Min. 30% of the species shall be broadleaved or floating leaved	24 in. ht.	Container grown
Frequently Fluctuating Zone (permanent water surface to 10 yr. water storm elev.)		
Live Fascines or Wattles 3 species in each fascine bundle Place parallel to contours Min. one layer of fascines at water's edge Do not use when facility is lined	4 in. diameter by 6 ft. length	Bound bundles

Table 4.1A
Minimum Planting Requirements at SWM Ponds
and Wetland Hydrologic Zones

Min. Quantity/ Placement Considerations	Min. Size/Rate	Root Condition
Plug Planting Min. 3 species of plugs shall be provided with no one species being greater than 50% of the total plants in this zone Plugs shall be spaced at max. 24 in. centers (2.9 plants per 10 sq. ft.)		
Seed and Mulch Shall be included to provide permanent stabilization SWM Seed Mix SHA Special Purpose Mix Mulch shall be according to Standard Specification for Construction Materials (SSCM) 2001, Section 705.03.01(f). No straw mulch shall be used at SWM facilities	16 lbs./ac. 10 lbs/ac.	
Perimeter Shade Planting (emergent & floating aquatic zone to 10 yr. water storm elev.)		
Canopy Trees 1 tree if areas is ≤ 4,000 SF (measured at 10 YR water surface contour line) 3 trees if (4,000 SF < area ≤ 8,000 SF) 5 trees if (8,000 SF < area ≤ 12,000 SF) If area > 12,000 SF, add 1 additional tree for each additional 4,000 SF If facility is lined, do not plant trees or woody shrubs within the limits of the liner	3 inch cal.	B & B
Understory or Flowering Trees 2 if area is ≤ 4,000 SF, add 1 additional tree for each additional 1,000 SF Multiple stemmed trees shall have a min. of 3 trunks.	2 in. cal.	B & B
Woody Shrubs 5 for every understory or flowering tree required	24 in. ht. or spread	Container Grown
Planting Bed Preparation Mulched beds shall not be used at SWM facilities below the 10 YR water surface elevation. Instead, individual plants shall be installed in plant pits that are not mulched. Areas between planting pits shall be stabilized with seed and mulch		
Seed and Mulch See Frequently Fluctuating Zone seed and mulch requirements.		

Table 4.1B
Minimum Planting Requirements for SWM Filtering Practices

Min. Quantity/ Placement Considerations	Min. Size/Rate	Root Condition
Sod Flow shall be diverted from filter practices until 2 in. ht. of permanent turf stabilization has been established. In cases where flow cannot be diverted, sod shall be applied to the filter surface. Sod shall be applied to all grass weirs except emergency spillways (which shall be established in permanent turf).	Section 708 Section 920 (SSCM 2001)	
Seed and Mulch SWM Seed Mix Special Purpose Mix	8 lbs / ac. 10 lbs / ac.	

Table 4.1B
Minimum Planting Requirements for SWM Filtering Practices

Min. Quantity/ Placement Considerations	Min. Size/Rate	Root Condition
No straw mulch shall be used at SWM facilities. Mulch shall be according to Section 920.05, SSCM 2001.		
Bioretention		
Trees min. 0.76 trees per 100 SF (filter surface area measurement) If the facility has underdrains or is lined, large canopy trees shall not be placed directly in the bioretention facility. Instead, they shall be used adjacent to the facility to provide shade to understory plants. In this case, plant large trees 5 feet away from the perimeter of the filter medium/underdrains or liner.	2 inch cal.	B&B
Shrubs Min. 2.8 shrubs per 100 SF (filter surface area measurement)	24 in. ht. or spread	Container Grown
Herbaceous layer 3 perennials or grasses can be substituted for 1 required shrub No more than 50% of plants shall be perennial or grasses	#1 container	Container Grown
Mulch 3 in. depth shredded hardwood mulch, evenly distributed and raked smooth	Section 920 (SSCM 2001)	

Reference Figure 4.1.11.C – Stormwater Pond Planting Zones, and Figure 4.1.11.D – Stormwater Pond Planting Plan Based on Minimum Planting Requirements, in Landscape Concept Plans.

Table 4.1C
Minimum Planting Requirements for SWM Open Channels

Min. Quantity/ Placement Considerations	Min. Size/Rate	Root Condition
Dry Swale		
Seed and Mulch SWM Seed Mix SHA Special Purpose Mix No straw mulch shall be used at SWM facilities. Mulch shall be according to Section 920.05, SSCM 2001.	8 lbs / ac. 10 lbs / ac.	
Wet Swales		
Emergent Species Grasses, rushes or grass-like species. No broadleaf species. 24 in. centers max. spacing (2.9 plants per 10 sq. ft.)	#SP4	Container Grown

4.1.14 Suggested Plant Material at SWM Areas

Plant selections for SWM areas can come from the following list. Native species are preferred but non-natives can be used if compelling reasons exist. The Design-Builder shall solicit Administration approval before using non-native plant material or material not on the following lists.

Submerged Aquatic Planting Zone

Botanical Name	Common Name
Elodea canadensis	Waterweed
Potamogeton pectinatus	Sago Pond Weed
Potamogeton perfoliatus	Redhead Grass
Vallisneria americana	Wild Celery

Emergent & Floating Aquatic Planting Zone

Botanical Name	Common Name
Emergents	
Acorus calamus	Sweet Flag (broadleaf)
Iris versicolor	Blue Flag (broadleaf)
Juncus canadensis	Canada Rush
Juncus effuses	Soft Rush
Nuphar luteum	Spatterdock (broadleaf)
Osmunda regalis	Royal Fern (broadleaf)
Peltandra virginica	Arrow Arum (broadleaf)
Pontederia cordata	Pickereelweed (broadleaf)
Sagittaria latifolia	Duck Potato (broadleaf)
Scirpus cyperinus	Woolgrass
Scirpus pungens	Common Three-square
Floating Aquatics	
Nelumbo lutea	Lotus
Nymphaea odorata	Fragrant Water Lily

Frequently Fluctuating Zone

Botanical Name	Common Name
Live Fascines:	
Salix nigra	Black Willow
Salix sericea	Silky Willow
Cornus amomum	Silky Dogwood
Cephalanthus occidentalis	Buttonbush
Plugs: (Note: Inclusion on this list does not guarantee availability in plug form)	
Chelone glabra	White Turtlehead
Dennstaedtia punctilobula	Hay-Scented Fern
Erythronium americanum	Trout Lily
Eupatorium dubium	Joe-Pye Weed
Eupatorium perfoliatum	Common Boneset
Lilium canadense	Canada Lily
Lilium superbum	Turk's Cap Lily
Lobelia cardinalis	Cardinal Flower
Lobelia siphilitica	Great Blue Lobelia
Oenothera fruticosa	Narrow-leaved Sundrops
Osmunda cinnamomea	Cinnamon Fern
Osmunda regalis	Royal Fern
Panicum virgatum	Switchgrass
Sisyrinchium atlanticum	Coastal Blue-eyed Grass
Solidago rugosa	Wrinkle Leaf Goldenrod
Thelypteris palustris	Marsh Fern
Tripsacum dactyloides	Gama Grass
Verbena hastate	Blue Vervain

Perimeter Shade Planting

Botanical Name	Common Name	Fall Color
Emergent Zone		
Canopy Trees:		
Acer rubrum	Red Maple	Yellow to Brilliant Red
Betula nigra	River Birch	Yellow

Botanical Name	Perimeter Shade Planting Common Name	Fall Color
<i>Carya cordiformis</i>	Bitternut Hickory	
<i>Carya glabra</i>	Pignut Hickory	Rich Golden Yellow
<i>Liquidambar styraciflua</i>	Sweetgum	Rich Yellow-Purple-Red
<i>Nyssa sylvatica</i>	Blackgum	
<i>Platanus occidentalis</i>	American Sycamore	
<i>Populus deltoides</i>	Eastern Cottonwood	
<i>Populus heterophylla</i>	Swamp Cottonwood	
<i>Quercus bicolor</i>	Swamp White Oak	Yellow (Red-purple)
<i>Quercus michauxii</i>	Swamp Chestnut Oak	
<i>Quercus phellos</i>	Willow Oak	Yellow, Bronze-Orange, Yellow-brown, Russet-red
Understory and Flowering Trees:		
<i>Alnus serrulata</i>	Smooth Alder	
<i>Amelanchier canadensis</i>	Serviceberry	
<i>Magnolia virginiana</i>	Sweetbay Magnolia	
<i>Viburnum prunifolium</i>	Black haw	
Shrubs:		
<i>Aronia arbutifolia</i>	Red chokeberry	
<i>Cephalanthus occidentalis</i>	Buttonbush	
<i>Hypericum densiflorum</i>	Dense St. John's Wort	
<i>Rhododendron maximum</i>	Rose Bay Rhododendron	
<i>Rhododendron periclymenoides</i>	Pink Azalea	
<i>Rhododendron viscosum</i>	Swamp Azalea	
<i>Rubus allegheniensis</i>	Allegheny Blackberry	
<i>Sambucus canadensis</i>	Common Elderberry	
<i>Viburnum prunifolium</i>	Black Haw	
Frequently Fluctuating Zone		
Canopy Trees:		
<i>Betula lenta</i>	Sweet or Black Birch	Golden Yellow
<i>Carya alba (tomentosa)</i>	Mockernut Hickory	Deep Golden Yellow to Golden Brown
<i>Carya ovata</i>	Shagbark Hickory	Rich Yellow to Golden Brown
<i>Diospyrus virginiana</i>	Common Persimmon	Yellow-green, Yellow or Reddish Purple
<i>Fagus grandifolia</i>	American Beech	Golden Bronze
<i>Fraxinus americana</i>	White Ash	Yellow to Deep Purple/Maroon
<i>Juniperus virginiana</i>	Eastern Redcedar	Bronze to Yellow Brown
<i>Pinus echinata</i>	Shortleaf Pine	
<i>Pinus stroblis</i>	White Pine	
<i>Pinus virginiana</i>	Virginia Pine	
<i>Prunus serotina</i>	Black Cherry	
<i>Quercus alba</i>	White Oak	Russet, Bronze, Red
<i>Quercus coccinea</i>	Scarlet Oak	
<i>Quercus palustris</i>	Pin Oak	Russet, Bronze or Red
<i>Quercus rubra</i>	Northern Red Oak	Russet-red, Bright-red
<i>Quercus stellata</i>	Post Oak	
<i>Quercus velutina</i>	Black Oak	

Botanical Name	Perimeter Shade Planting Common Name	Fall Color
<i>Tilia americana</i>	American Basswood	
<i>Tsuga canadensis</i>	Eastern Hemlock	Evergreen
<i>Ulmus rubra</i>	Slippery Elm	
Understory and Flowering Trees:		
<i>Carpinus caroliniana</i>	American Hornbeam	
<i>Corylus americana</i>	American Hazelnut	
<i>Cercis canadensis</i>	Eastern Redbud	
<i>Chionanthus virginicus</i>	White Fringetree	
<i>Cornus florida</i>	Flowering Dogwood	
<i>Crataegus crus-galli</i>	Cockspur Hawthorn	
<i>Ilex decidua</i>	Possom Haw	
<i>Kalmia latifolia</i>	Mountain Laurel	
<i>Ilex opaca</i>	American Holly	Evergreen
<i>Juniperus virginiana</i>	Eastern Redcedar	
<i>Sassafras albidum</i>	Sassafras	
Shrubs:		
<i>Comptonia peregrina</i>	Sweet Fern	
<i>Cornus amomum</i>	Silky Dogwood	
<i>Euonymus americanus</i>	Strawberry Bush	
<i>Hamamelis virginiana</i>	Witchhazel	
<i>Hydrangea arborescens</i>	Wild Hydrangea	
<i>Leucothoe racemosa</i>	Fetterbush	
<i>Lyonia ligustrina</i>	Male-berry	
<i>Gaylussacia baccata</i>	Black Huckleberry	
<i>Rhus glabra</i>	Smooth Sumac	
<i>Vaccinium corymbosum</i>	Highbush Blueberry	
<i>Vaccinium stamineum</i>	Deerberry	
<i>Vaccinium vacillans</i>	Early Lowbush Blueberry	
<i>Viburnum acerifolium</i>	Maple-Leaved Arrowwood	
<i>Viburnum dentatum</i>	Southern Arrowwood	
Bioretention Planting		
Botanical Name	Common Name	
Trees:		
<i>Acer rubrum</i>	Red Maple	
<i>Betula lenta</i>	Sweet Birch	
<i>Carya glabra</i>	Pignut Hickory	(if no underdrains)
<i>Cercis canadensis</i>	Eastern Redbud	
<i>Chionanthus virginicus</i>	White Fringetree	
<i>Cornus florida</i>	Flowering Dogwood	
<i>Crataegus crus-galli</i>	Cockspur Hawthorn	
<i>Diospyrus virginiana</i>	Common Persimmon	(if no underdrains)
<i>Juniperus virginiana</i>	Eastern Redcedar	
<i>Nyssa sylvatica</i>	Black Gum	(if no underdrains)
<i>Pinus echinata</i>	Shortleaf Pine	(if no underdrains)
<i>Pinus strobes</i>	White Pine	(if no underdrains)
<i>Pinus virginiana</i>	Virginia Pine	(if no underdrains)
<i>Quercus rubra</i>	Northern Red Oak	(if no underdrains)
<i>Quercus velutina</i>	Black Oak	(if no underdrains)

Botanical Name	Bioretention Planting Common Name
Shrubs	
<i>Aronia arbutifolia</i>	Red Chokeberry
<i>Hamamelis virginiana</i>	Witchhazel
<i>Hypericum densiflorum</i>	Dense St. John's Wort
<i>Ilex decidua</i>	Possum Haw
<i>Kalmia latifolia</i>	Mountain Laurel
<i>Lindera benzoin</i>	Spicebush
<i>Rhus glabra</i>	Smooth Sumac
<i>Vaccinium corymbosum</i>	Highbush Blueberry
<i>Viburnum acerifolium</i>	Maple-leaved Arrowwood
<i>Viburnum dentatum</i>	Southern Arrowwood
Herbaceous	
<i>Aquilegia canadensis</i>	Eastern Columbine
<i>Asclepias incarnata</i>	Swamp Milkweed
<i>Asclepias tuberosa</i>	Butterflyweed
<i>Aster divaricatus</i>	White Wood Aster
<i>Aster ericoides</i>	Heath Aster
<i>Aster novi-belgii</i>	New York Aster
<i>Baptisia australis</i>	Blue False Indigo
<i>Eupatorium fistulosum</i>	Joe-Pye Weed
<i>Eupatorium rugosum</i>	White Snakeroot
<i>Heliopsis helianthoides</i>	Oxeye Sunflower
<i>Hepatica americana</i>	Round-lobed Hepatica
<i>Heuchera americana</i>	Alumroot
<i>Liatris graminifolia</i>	Grass-Leaf Blazingstar
<i>Monarda fistulosa</i>	Wild Bergomot
<i>Penstemon digitalis</i>	Beardtongue
<i>Physostegia virginiana</i>	Obedient plant
<i>Polygonatum biflorum</i>	Solomon's Seal
<i>Rudbeckia fulgida</i>	Early Coneflower
<i>Rudbeckia hirta</i>	Black-eyed Susan
<i>Rudbeckia laciniata</i>	Tall Coneflower
<i>Rudbeckia triloba</i>	Three-lobed Coneflower
<i>Saxifraga virginiana</i>	Early Saxifrage
<i>Silene stellata</i>	Starry Companion
<i>Solidago caesia</i>	Blue-stemmed Goldenrod
<i>Solidago rigida</i>	Rigid Goldenrod
<i>Solidago speciosa</i>	Showy Goldenrod

Code 378 Embankments

Botanical Name	Common Name
SHA Permanent Seed Mix	
SHA Special Purpose Mix	
<i>Andropogon virginicus</i>	Broomsedge
<i>Bouteloua curtipendula</i>	Sideoats Grama
<i>Dichanthelium clandestinum</i>	Deertongue
<i>Elymus canadensis</i>	Canada Wild Rye
<i>Elymus virginicus</i> L.	Virginia Wildrye
<i>Eragrostis curvula</i>	Weeping Lovegrass
<i>Panicum virgatum</i>	Switchgrass

Code 378 Embankments

Botanical Name	Common Name
Schizachyrium scoparium	Little Bluestem
Sorghastrum nutans	Indiangrass
Tripsacum dactyloides	Eastern Gama Grass

4.1.15 Additional Requirements for SWM Areas

4.1.15.1 SWM Visual Quality Monitor

The Administration will provide a SWM Visual Quality Monitor (SWM VQ Monitor) to review and provide written comment to SWM facility design plans, in addition to and to oversee grading, planting, outfall structure pigmentation and safety features. Visual and environmental quality and safety shall be accommodated in the final SWM facility designs. This shall be accomplished with input of the Design-Builder's Landscape Architect.

The Design-Builder shall coordinate visual quality review for SWM facilities with the Administration. This review shall consist of a meeting to discuss the SWM facilities as they relate to visual and environmental quality and safety.

Consultation and written comments offered by the Administration shall be incorporated into the SWM facility design. The Administration's written comments shall be satisfactorily addressed and resolved before finalizing the SWM facility plans.

4.1.15.2 Woody Plant Restrictions and Buffer Zones

Planting of woody species, including live fascines, shall be in accordance with Pond Code 378 requirements at SWM embankments and SWM outfall structures. No woody material shall be planted on the SWM embankment (roadway and non-roadway), within 15 feet of the toe of SWM embankment fill or within 25 feet of the SWM outfall structure.

A 15-foot buffer zone within Administration right-of-way shall be provided at the toe of SWM embankments (roadway and non-roadway) that shall be maintained free of woody vegetation.

4.1.15.3 Planting Height Restrictions at SWM Embankments

SWM embankments and buffer zones shall be planted with warm season grasses and/or turf grass that can be maintained to a height of 10 inches.

4.1.15.4 Soil Amendments (Fertilizer, Lime, Compost)

Soil amendments shall be applied as required according to soil testing to achieve healthy growth of plants and seed areas to ensure establishment. This includes turf establishment and plant pit amendments.

Areas targeted for warm season grass and native meadow establishment should not be amended with fertilization and other amendments.

4.1.15.5 Bioretention Soil Mix (BSM)

BSM is a blended mixture of sand, mulch and planting soil that is used at the filter medium in bioretention facilities, surface sand filters and dry swales. BSM shall be a homogeneous mix, free of stones, stumps, roots or other similar objects larger than 2 in. and shall be free from any parts of Bermuda grass, Quackgrass, Johnsongrass, Mugwort, Nutsedge, Poison Ivy, Canadian Thistle, Tearthumb, Phragmites or other noxious weeds as specified in COMAR 15.08.01.05

Care shall be taken when placing BSM and planting and watering within BSM to ensure that excessive compaction is avoided.

BSM shall consist of the following textural grading analysis:

Item	Criteria	Test Method
Sand (2.0 – 0.050 mm)	65 – 80%	T88
Silt (0.050 – 0.002 mm)	0 – 15%	T88
Clay (less than 0.002 mm)	1 – 5%	T88
Organic Matter	15 – 25%	T194

BSM shall also be sampled in conformance with MSMT 356 and meet the following criteria:

Item	Criteria	Test Method
pH	5.5 – 7.5	D4972
Magnesium	Minimum 35 ppm	*
Phosphorus (Phosphate – P ₂ O ₅)	Minimum 75 ppm	*
Potassium (K ₂ O)	Minimum 85 ppm	*
Soluble Salts	Not to exceed 500 ppm	*

* University of Delaware, College of Agriculture and Natural Resources, Soil Testing Program Test Method

4.1.15.6 SWM Seed Mix

The seed mix used at frequently fluctuating zone, surface sand filter and dry swale facilities shall be according to the following percentages. The rate of application is listed under Minimum Planting Requirements above.

Botanical Name	Common Name	Percent of Mix
Andropogon gerardii	Big Bluestem	50%
Bromus inermis	Smooth Brome	25%
Panicum virgatum	Switchgrass	25%

Seeding Seasons for SWM Seed Mix are listed in the following table.

REGIONS	SPRING AND FALL (MONTH/DAY)	SUMMER (MONTH/DAY)	LATE FALL (MONTH/DAY)
1. Montgomery County	3/1 to 5/15 and 8/1 to 10/20	5/16 to 7/31	10/21 to 11/20
2. Prince George's County	3/3 to 5/1 and 8/1 to 10/31	5/2 to 7/31	11/1 to 11/30
1 and 2	No Additives	Plus Additive A	Plus Additive B
	Plus Additive C for seeding: Slopes 4:1 and steeper		
3. ADDITIVES A = Lovegrass or Foxtail Millet B = Temporary Seed Mix C = Sericea Lespedeza			

NOTE: The Design-Builder shall supply substitute seed for Lovegrass, Foxtail Millet, and Sericea Lespedeza when seeding within 4 miles of a State airport.

Regions	Spring and Fall (Month/Day)	Summer (Month/Day)	Late (Month/Day)	Fall
1. Montgomery County	3/1 to 5/15 and 8/1 to 10/20	5/16 to 7/31	10/21 to 11/20	
2. Prince George's County	3/3 to 5/1 and 8/1 to 10/31	5/2 to 7/31	11/1 to 11/30	
1 and 2	No Additives	Plus Additive A	Plus Additive B	
	Plus Additive C for seeding: Slopes 4:1 and steeper			
3. ADDITIVES A = Lovegrass or Foxtail Millet B = Temporary Seed Mix C=Sericea lespedeza, unless within 1,000 feet of MNCPPS property.				

NOTE: The Design-Builder shall supply substitute seed for Lovegrass and Foxtail Millet when seeding within 4 miles of a State airport. Refer to Part 007-Engineering Data for seed mix to be used within 1,000 feet of MNCPPC property.

SWM Structure Color

Cleanouts and vents shall be black in color. Riprap stone used for aprons, channel lining, check dams, and outfall stabilization shall be brown or gray in color; no white riprap shall be used on the Project. All Concrete outfall structures that are visible from the roadway or adjacent property shall be stained with the same light brown or light grey color (Federal Standard 595B colors: 30277, 30145, or 30219).

SWM Facility Safety

The Administration discourages the use of fencing at SWM facilities wherever possible while ensuring safety. Safe design can be incorporated in many ways such as selection of appropriate facility types, flat side slopes, benches, planting, and proper design of the riser structure. Deterrent features such as fencing shall only be used after an attempt to design safety features has shown that fencing is warranted.

Facilities designed with permanent water levels, including forebays, of greater than 2 feet require design and construction of the following safety features:

- A) NO TRESPASSING signs shall be placed so as to be visible from all adjacent properties. At a minimum, one sign shall be placed for each facility at the access point, with additional signs added as necessary to ensure that potential trespassers from adjacent properties are alerted.
- B) Side slopes shall be 4:1 or flatter. This includes both the upstream and downstream sides of stand-alone SWM embankments and roadway SWM embankments. Cut slopes with reforestation can be steeper than 4:1 with Administration approval.
- C) Benches shall be placed around the perimeter of permanent pools that are 2 ft. or greater in depth. The benches shall be a minimum 15 ft. wide and centered at the permanent pool elevation with a grade of 12:1 or flatter.

Hydraulic Structures

Safety shall be considered in the design and placement of hydraulic structures including risers, weirs, headwalls and end walls. Structure design shall provide the safety features listed below in order to ensure that the facilities are safe without the use of railings.

- A) Control Riser & Weir Structures shall include a minimum 4ft.-2in. dimension or greater on two consecutive sides adjacent to the manhole cover shall be provided at the top of riser structures that are 30 in. or greater in height to allow maneuvering of the manhole cover from the frame. Reference Figure 3.1.13.E – Plan of Riser Structure, in Landscape Concept Plan.
- B) Riser and weir structure height shall be less than 48 inches to ground surface, even if

the ground surface is submerged. If the structure is placed on a bench, there shall be a minimum of 5 feet from the structure to edge of permanent water surface.

- C) Railings shall be provided at headwalls or end walls that are 48 inches or greater in height from top of wall to the ground surface. Fencing shall be 42 inches in height and black or brown coated chain link with a top rail. Reference Figure 4.1.1.F – Chain Link Railing at Outfall Structure, in Landscape Concept Plan.

Stabilized Maintenance Access

A stabilized maintenance access from a paved surface in a public right-of-way to all SWM facilities shall be provided and shall conform to the following:

- A) A 12 ft. wide maintenance access shall be provided to the facility bottom, forebay bottom, in flow and outflow structures. The maintenance access shall consist of stabilized soil constructed with a 6 inch depth cellular confinement system filled with open graded aggregate, topped with 4 inches of topsoil and seeded and mulched.
- B) Turnarounds shall be provided at the top and bottom of the access that allow large maintenance vehicles to turn completely around where possible. Room shall be provided at the entrance for a maintenance truck with trailer to pull completely off the roadway without blocking the maintenance access.
- C) The preferred maximum slope at maintenance access shall not exceed 8:1 (12%). The Administration may approve slopes as steep as 6.6:1 (15%) when conditions warrant.
- D) The surface of the maintenance access road shall be a minimum of 1 ft. above any permanent water surface.
- E) The entrance shall not be blocked with traffic barrier, parking or other permanent obstructions. A depressed curb and/or concrete apron shall be required at locations designated by the Administration.
- F) A 12 ft. wide double gate shall be provided where fencing is used at the stabilized maintenance access. A method to secure the gate in the closed position and an exterior grade padlock and with 2 keys shall be provided to the Administration for each gate.

SWM Planting Plan Requirements

The locations and depths of liners shall be shown clearly on planting plans. Woody trees and shrubs shall not be planted over liners.

A note shall be added to the plans when planting over liners that care shall be taken not to puncture them. No augers of any kind shall be used when digging plant pits over liners.

The planting zones (submerged aquatic, emergent & floating aquatic, frequently fluctuating) shall be shown on the plan and clearly labeled. The contour line and elevation label for the permanent water elevation and the 10 year storm elevation shall be shown and labeled.

Contour Grading and Mowability at SWM Facilities

Contour grading at SWM facilities shall incorporate curvilinear shapes with minimal straight lines and sharp angles. Landforms shall be graded into the facility shape to increase the flow path and provide visual interest. Landforms shall be natural in design and blend well with the SWM facility and surrounding landscape.

Grade steepness shall be dictated by safety (see above) and mowability. Areas that require routine

mowing shall be 4:1 or flatter. Routine mowing is required at the following areas:

- A) Maintenance Access;
- B) SWM embankment (both upstream and downstream faces);
- C) 15 foot clear zone at embankment toe;
- D) Around outfall structure;
- E) Emergency spillway;
- F) Bottom and side slopes of dry swales and surface sand filters; and
- G) Filter strips at grass channels, infiltration basins, infiltration trenches, dry swales and Bioretention.

Grading and planting design shall incorporate areas requiring mowing into the design and layout. Access shall be provided to all mowing areas from the maintenance access. Dimensions and turning requirements of standard mowing equipment shall also be accommodated in the design.

SWM As-Built Certification for Plant and Turf Survivability

In addition to requirements identified in the Drainage Performance Specification, the SWM as-built certification includes submission of documentation and verification of minimum survival rates for plants at SWM facilities and turf within conveyances to the facilities.

Inspections of planting installations and survival and final turf establishment shall be performed by a registered Landscape Architect in the State of Maryland and an Administration approved Environmental Analyst. The inspector shall have experience in stormwater management planting design and construction.

4.1.14 Plant and Turf Establishment Certification Package

The Design-Builder shall submit a plant and turf establishment certification package that consists of field photos, completed turf inspection checklists, completed planting checklists and the contract planting plans and details. If survivability percentages are not achieved, notation shall be made on the plans and report designating the plants or areas that are dead or exhibit patchy growth. A description of efforts taken to bring the plantings or turf up to the required survivability shall be included in the report. A schedule for implementing the remediation efforts and documentation of completion of the remediation efforts shall be included.

The plant and turf establishment certification process shall be completed and approved as a condition of Acceptance for Maintenance.

Stages for Plant and Turf Establishment Inspections.

At the two year care and replacement inspection, the plant and turf establishment inspection shall also be conducted and documented. Plants shall be inspected for species, size, quantity, health and location. Plants that measure smaller than the installed size shall be considered dead and replaced. Plant and turf establishment inspections shall be conducted in accordance with the Administration's standards.

The following planting and turf shall be inspected and documented:

- A) Ponds and Wetlands.
- B) SWM embankment (including roadway embankment if applicable) and clear zone 15 feet beyond toe of embankment cleared of woody vegetation and established with turf

or native grasses: During second growing (plant establishment phase inspection) season to verify a vegetation survival rate at submerged benches and wetlands of 50 %.

- C) Infiltration Trenches: Turf establishment with 95% coverage of SHA permanent seed mix inspected in conveyances, filter strips and other features draining to the trench that are within the Administration right-of-way and within the Project site. Off-site areas shall be visually observed and the location of off-site eroded or bare areas included in the report and photographed.
- D) Infiltration Basins: Woody plant clear zones listed for Ponds above. Plant, turf or native meadow establishment inspected at basin bottom and side slopes. Establishment of turf with 95% coverage on all conveyances draining to the facility within the Administration right-of-way and within the Project site. Off-site areas shall be visually observed and the location of off-site eroded or bare areas included in the report and photographed.
- E) Filtering Systems: Establishment of turf on weir, bottom and sides of facility, and all conveyances draining to the facility. At Bioretention Facilities, to verify a plant survival rate of at least 90 %. The mulch bed shall be inspected and replenished to constructed depth and condition.
- F) Open Channel Systems: For Dry Swales, inspect establishment of turf on weir, bottom, side slopes and conveyances draining to the facility. For Wet Swales, inspect establishment of turf on weirs, sides and all conveyances draining to the facility. Inspect planting at bottom of facility for 50 % survival rate.

4.1.15 Sound Barrier/Retaining Wall Treatment (Landscape RFP Plan Symbol "WA")

The Design-Builder shall prepare Landscape Plans for the Planting adjacent to the noise barriers; which includes only the side facing the roadway corridor. The planting shall be integrated with the Landscape Concept Plan chosen for the roadway corridor and compatible with adjacent plantings, land uses and surroundings. The Design-Builder shall employ this plant association within the restricted root zones adjacent to the tops and toes of all walls, whether cast-in-place, or mechanically-stabilized earth (M.S.E.) areas throughout the entire Project area. Shade trees and evergreens shall not be planted closer than 15 feet from the noise barrier/retaining wall face. Columnar shade trees and evergreens shall not be planted closer than 10 feet from the noise barrier/retaining wall face. Vines shall be planted along the walls at 4 feet on center. The density of plantings shall be 1 ornamental tree for each 100 square feet, 1 shrub for each 25 square feet, 1 ornamental grass for each 10 square feet, 1 herbaceous plant for each 2.25 square feet, and where possible, 1 shade tree for each 1500 square feet and 1 evergreen tree for each 3000 square feet. Within each WA planting zone, as illustrated on the Landscape Concept Plans or as defined by the final sound barrier design locations, a minimum of five herbaceous species and three shrubs shall be selected for use. Hemerocallis shall be used in groupings of 100 of the same cultivar. Reference Figure 1.1.12.A – Sound Barrier Sight Lines, and Figure 1.1.12.B – Sound Barrier/Retaining Wall Stepped Planting Condition, in Landscape Concept Plans. Plant selections shall be appropriate for the field environmental conditions of the planting site. The approved plant species, minimum acceptable sizes, and minimum spacing are listed below:

PLANT MATERIAL: Sound Barrier/Retaining Wall Treatment – "WA"

Botanical Name	Common Name	Maximum Spacing	Minimum Size
Shade Trees			
Acer rubrum	Red Maple	40' OC	2" Cal. B&B
Acer rubrum 'Armstrong'	Armstrong Maple	40' OC	2" Cal. B&B
Acer rubrum 'Bowhall'	Bowhall Maple	40' OC	2" Cal. B&B
Quercus palustris	Pin Oak	40' OC	2" Cal. B&B

Juniperus virginiana	Eastern Red Cedar	15' OC	6' Ht. B&B
Pinus strobus	White Pine	20' OC	6' Ht. B&B
Deciduous Shrubs			
Cornus sericea	Red-Osier Dogwood	5' OC	3' Ht. CG
Forsythia x intermedia	Border Forsythia	5' OC	3' Ht. CG
Ilex glabra	Inkberry Holly	5' OC	3' Ht. CG
Ilex verticillata	Winterberry	5' OC	3' Ht. CG
(OED approved sp.) (Provide adequate # of male plants)			
Ligustrum obt. regalianum	Regal Privet	5' OC	3' Ht. CG
Ligustrum ovalifolium	California Privet	5' OC	3' Ht. CG
Myrica pensylvanica	Northern Bayberry	6' OC	3' Ht. CG
Rhus aromatica	Fragrant Sumac	5' OC	3' Ht. CG
Rhus glabra	Smooth Sumac	5' OC	3' Ht. CG
Spirea sp.	Spirea (OED approved sp)	5' OC	3' Ht. CG
Viburnum acerifolium	Mapleleaf Viburnum	5' OC	3' Ht. CG
Viburnum dentatum	Arrowwood Viburnum	5' OC	3' Ht. CG
Viburnum prunifolium	Blackhaw Viburnum	5' OC	3' Ht. CG
Evergreen Shrubs			
Juniperus conferta hybrids CG	Shore Juniper	3' OC	15" Spread,
Juniperus sp. CG	Juniper	3' OC	15" Spread,
(OED approved sp.)			
Viburnum pragnense	Prague Viburnum	5' OC	3' Ht. B&B
Herbaceous Species			
Hemerocallis 'Hyperion'	Hyperion Daylily	24" OC	1 Gal. CG
Hemerocallis 'Catherine Woodbury'	Daylily	24" OC	1 Gal. CG
Hemerocallis 'Happy Returns'	Happy Return Daylily	24" OC	1 Gal. CG
Hemerocallis	Daylily	24" OC	1 Gal. CG
(OED approved sp) (Light colors only)			
Vines			
Parthenocissus quinquefolia	Virginia Creeper	4' OC	1 Gal. CG
Partheonocissus tricuspidata	Boston Ivy	4' OC	1 Gal. CG
Ornamental Grasses			
Calamagrostis acutiflora (OED approved sp.)	Feather Reed Grass	4' OC	1 Gal. CG
Deschampsia caespitosa	Tufted Hair Grass	24" OC	1 Gal. CG
Panicum virgatum (OED approved sp.)	Switch Grass	4' OC	1 Gal. CG
Sorghastrum nutans	Indian Grass	4' OC	1 Gal. CG

Note: CG indicated Container Grown, B&B indicates Balled and Burlap, OC indicates On Center Spacing.

4.2 LANDSCAPE REQUIREMENTS

(OED approved sp.)

Sorghastrum nutans

Indian Grass

4' OC

1 Gal. CG

Note: CG indicates Container Grown, B&B indicates Balled and Burlapped, OC indicates On Center Spacing.

4.2 LANDSCAPE REQUIREMENTS

4.2.1 Noxious Weed Control

The Design-Builder shall be responsible for the control of noxious weed species within the Project ROW, easements, and limits of disturbance. This shall apply to noxious weeds listed by the Maryland Department of Agriculture (MDA) and in accordance with MDA requirements. The Design-Builder shall prepare and submit a noxious weed control plan to the Administration prior to the commencement of eradication or removal work for consultation and written comments. If chemicals are proposed, they shall be applied by a Maryland Certified Pesticide Applicator, licensed by the MDA.

4.2.2 Contour Grading

The Design-Builder shall perform contour grading throughout the limits of the Contract. Contour grading for both cut and fill conditions shall be performed so that the resultant landforms are natural in appearance, blend well with the surrounding landscape and built features, facilitate positive drainage, and minimize opportunities for erosion. Grading shall be performed to maintain desirable existing vegetation and accommodate the Contract's landscape plantings. Changes in slopes shall be rounded to appear smooth and natural. Slopes to be routinely mowed shall be no steeper than 4:1.

4.2.3 Right of Way Fence

The ICC passes through an area with a large wildlife population. Therefore, it is imperative to prohibit animals from entering the ICC roadway. To prevent access of wildlife and pedestrians to the roadway, the Project shall be continuously fenced. Chain link right-of-way fence shall be constructed to direct deer and other animals to crossings at culverts or beneath bridges along the Project. Chain link fence shall be constructed such that ditch crossings are minimized to the greatest extent possible. Positive drainage and prohibiting access to the roadway shall be required where right-of-way fence crosses a ditch. Right-of-way fence shall be constructed such that the need for gates to the community side of the fence is minimized. Right-of-way fence shall be black vinyl coated chain link and constructed within 2 feet inside the Project right-of-way line, unless otherwise specified, and in accordance with Section 607 - Chain Link Fence of the SHA Standard Specifications for Construction and Materials. Alignment of right-of-way fence shall be adjusted to minimize clearing of and damage to existing trees.

East of the CSXT/MARC line, right-of-way fence shall have a minimum exposed height of 8 feet above grade and shall be buried a minimum 1 foot below grade to obstruct wildlife from burrowing under the fence. Construction methods utilized to bury the fence shall minimize to the greatest extent possible impacts to the critical root zone of trees beyond the limit of disturbance. The critical root zones of specimen trees shall not be impacted. The interchanges at the Metro Access Road and MD 97 shall be fenced with the same chain link fence to prevent wildlife from entering the interchanges.

West of the CSXT/MARC line, right-of-way fence shall have a minimum exposed height of 6 feet above grade, but is not required to be buried.

Right-of-way terminal posts shall be securely attached to noise barriers, headwalls, retaining walls, bridges and other structures to prevent wildlife and pedestrians from access to the roadway.

Existing right of way fencing within the Project limits shall be removed and replaced with the appropriate fence as specified in this section.

4.2.4 Shared Use Separation Fence

Chain link fence shall be constructed to separate the Shared Use Path, also referred to as the Bike Trail or Path, from the ICC mainline roadway and ramps. Shared Use Path Separation Fence shall be 3.5 feet in height and shall have knuckled selvage at the top and bottom of the fence. A tension wire shall be run continuously between terminal posts near the top and bottom of the fabric and attached to the chain link with hog ring fasteners at 18 inch intervals. Shared Use Path Separation Fence shall be black vinyl coated with fencing material installed on the Share-Use Path side of posts.

4.2.5 Wildlife Fence and Escape Requirements

Wildlife fence shall be required to prohibit small mammals, amphibians and reptiles from entering the Project roadway and intended to direct wildlife to culvert crossings and beneath bridges along the Project. Wildlife fence shall to the greatest extent possible be constructed to avoid ditch crossings.

Wildlife fence shall be 16 to 20 gauge black coated vinyl welded wire mesh with 0.25 inch x 0.25 inch openings installed with a minimum of 3 feet exposure above grade and buried a minimum of 6 inches below grade. Wildlife Fence shall be securely attached to the bottom of Right of Way Fencing constructed adjacent to forested areas. and applied along forested areas, streams and adjacent to stormwater management ponds. Wildlife Fence shall be installed on the side furthest from the roadway and shall have a 2 inch 90 degree lip at the top to obstruct small animals from scaling the Wildlife Fence. Limits of existing forest and streams are shown in the Final Environmental Impact Statement.

The Design-Builder may propose other designs to prohibit small mammal, amphibian and reptiles from entering the mainline roadway and ramps.

Earthen escape ramps shall be provided as escape points for wildlife trapped within the fences right-of-way areas. Earthen ramp locations shall be proposed by the Design-Builder and coordinated with the Administration. One-way gates will not be allowed.

4.2.6 Access Gates

Access Gates shall be provided for maintenance access. Access gates shall be 12 foot wide double gates (each leaf 6 feet wide) and shall match the height and material of adjacent fencing. An exterior grade padlock with 2 keys shall be provided for each gate. Gates shall not be blocked with guardrail, parking or any permanent obstructions. Right-of-way fencing shall have access gates located no further than 1,000 feet apart.

Access gate locations shall be coordinated with the Administration and utility owners.

4.2.7 SWM Fence

SWM fencing shall be constructed and consist of black vinyl coated chain link fencing. Chain link fencing shall be provided according to the Administration's Pond Fencing Guidelines with a height of 3.5 feet and be placed so as to be visually unobtrusive. Fencing shall be required and constructed at SWM facilities when safety features can not be incorporated into the design and construction.

When chain link fencing is used at stormwater management facilities a top rail shall run continuously between terminal posts at the top of the chain link. Chain link shall be tied to the top rail at 2 foot

padlock with 2 keys shall be provided for each gate. Gates shall not be blocked with guardrail, parking or any permanent obstructions. Right-of-way fencing shall have access gates located no further than 1,000 feet apart.

Access gate locations shall be coordinated with the Administration and utility owners.

4.2.7 SWM Fence

SWM fencing shall be constructed and consist of black vinyl coated chain link fencing. Chain link fencing shall be provided according to the Administration's Pond Fencing Guidelines with a height of 3.5 feet and be placed so as to be visually unobtrusive. Fencing shall be required and constructed at SWM facilities when safety features can not be incorporated into the design and construction.

When chain link fencing is used at stormwater management facilities a top rail shall run continuously between terminal posts at the top of the chain link. Chain link shall be tied to the top rail at 2 foot maximum spacing. The top rails shall conform to the brace rail and brace rail attachment specifications. No brace rail is required when top rails are used.

A tension wire shall be run continuously between terminal posts near the bottom of the fabric and be attached to the fabric with hog ring fasteners at 18 inch intervals. A 12 foot wide double gate shall be constructed at each SWM facility requiring fencing.

4.2.8 SWM Fence Requirements

See Figure 3.1.13.F – Black Vinyl Coated Chain Link Fence with Top Rail, in Landscape Concept Plans.

5.0 SUBMITTALS

5.1 FINAL ROADSIDE PLANTING PLAN

Final landscape planting plan shall include all plant types, sizes and locations for the Project. The plans shall include all proposed wetland and stream restoration plantings and shall be submitted at a scale of 1 inch equals 50 feet.

5.2 NUTRIENT MANAGEMENT PLAN/REPORT

The Design-Builder shall comply with the Maryland Nutrient Management Law and regulations.

Prior to performing turf establishment and sodding, the Design-Builder shall sample and test soils for texture, pH, organic matter, phosphorous and potassium needs in accordance with the procedures identified in the Administration's MSMT 356 "Sampling and Testing Soil for Nutrient Management Plan".

The procedures described in the above MSMT 356 shall be used in determining if stockpiles are suitable for use as furnished topsoil. Information on the rootmat and topsoil are included in the geotechnical boring logs contained in Part 7-Engineering Data.

The Design-Builder shall use the soil test results and obtain the services of a Maryland certified Nutrient Management Consultant to develop a Nutrient Management Plan for nitrogen, phosphorus, potassium, limestone, organic matter and sulfur input levels for the Project. A directory of certified Nutrient Management Consultants may be found by contacting the Nutrient Management Program at 410-841-5959.

The Design-Builder shall submit and soil test results and the Nutrient Management Plan to the Administration for consultation and written comments.

5.3 SOILS REPORTS

The Design-Builder submit all soil testing reports to the Administration. Soil testing shall be performed for texture, particle size gradation, pH and organic content. The soil report shall be completed and submitted in advance of the Nutrient Management Plan and coordinated with its requirements.

6.0 WARRANTIES

The Design-Builder shall provide warranty and maintain all landscape plantings for two years after Acceptance for Maintenance of plantings and landscape Work. Acceptance Maintenance for plantings and landscape Work shall be implemented after all plant materials in the Project have been planted, are true to species and minimum size, and are in a healthy and thriving condition. In addition, each plant pit or bed shall be properly filled, mulched, pruned and staked. During this two year Warranty period, the Design-Builder shall provide all required plant care and maintenance. This work shall include, but is not limited to: watering, weeding, fertilizing, pest control, invasive plant control, mulching, pruning, and replacement of any plant materials that are not in a healthy and thriving condition reflective of the species and in accordance with SHA Standard Specification for Construction and Materials section 705, 708, and 710.

This 2-year plant material warranty shall apply to all landscaping, reforestation, wetland, stormwater management and reforestation plantings required in the Project. The replacement of plants for SWM areas shall be as noted in Section 4.1.14-Stages for Plant and Turf Establishment Inspections of this Performance Specification.

At the end of the 2-year warranty period, the Design-Builder shall submit a turf establishment certification package that consists of field photographs and completed turf inspection checklists. All turf areas shall be of uniform color and density acceptable to the Administration.

PS 303 - DRAINAGE PERFORMANCE SPECIFICATION

1.0 GENERAL

The Project requires a combination of roadway reconstruction and new construction. Reconstruction areas shall require assessment to determine adequacy of existing drainage systems (e.g. capacity, outfall stability, system condition, and other parameters) to meet ICC drainage needs and future roadway needs as identified in the Roadway Performance Specifications. New construction areas shall require complete design and construction of new drainage systems. The Mainline of the proposed roadway is open section with median and roadside ditches. Segments of Mainline, ramps, local road connections, noise walls and bridges may require closed drainage systems, e.g. curb, gutter and storm drains.

2.0 STANDARDS AND REFERENCES

2.1 STANDARDS

Design and construct the drainage system in accordance with the relevant requirements of the Standards listed by priority in Table 1, unless otherwise stipulated in this specification. Standards specifically cited in the body of this specification establish requirements that shall have precedence over all others. Should the requirements in any standard conflict with those in another, the standard listed with the higher priority shall govern. The Design-Builder shall obtain clarification for any unresolved or perceived ambiguity prior to proceeding with design of construction.

Use the most current version of each listed standard as of the publication date of this RFP.

**TABLE 1
 STANDARDS FOR DRAINAGE**

Priority	Author or Agency	Title
1	SHA	Maryland Department of Transportation, publications entitled "Highway Drainage Manual" dated December 1981 or as amended herein and any revisions thereof.
2	MDE	Regulation COMAR 26.09.01, "Erosion and Sediment Control"
3	MDE	"Erosion and Sedimentation Guidelines for State and Federal Projects"
4	MDE	"1994 Maryland Standards and Specifications for Soil Erosion and Sediment Control"
5	MDE	MDE Regulation COMAR 26.08.04, "National Pollutant Discharge Elimination System General Permit for Construction Activity".
6	MDE	Regulations COMAR 26.17.02, "Stormwater Management"
7	MDE	"Stormwater Management Guidelines for State and Federal Projects"
8	MDE	"2000 Maryland Stormwater Design Manual", Volumes I and II.
9	Montgomery County Maryland	Code Section 19-65(a)(2)(B) "Special Protection Areas"
10	MDE	Regulations COMAR 26.17.04 "Construction on Nontidal Water and Floodplains."

**TABLE 1
STANDARDS FOR DRAINAGE**

Priority	Author or Agency	Title
11	MDE	"Guidelines for Construction on Nontidal Waters and Floodplains."
12	MDE	Regulation COMAR 26.08.02.10, "Water Quality Certification"
13	SHA	"Stormwater Management, Erosion and Sediment Control and Waterway Construction Permit Issues and Approaches"
14	SHA	Standard Specifications for Construction and Materials for items identified as Standard in Attachment A of Part 3-Design Requirements.
15	SHA	Book of Standard for Highways, Incidental Structures and Traffic Control Applications for items identified as Standard in Attachment B of Part 3-Design Requirements
16	FDOT	"State of Florida DOT Drainage Manual", January 2006, Tables 6.2 and 6.3 regarding service life of corrugated metal pipes

2.2 REFERENCES

Use the references listed in Table 2 as supplementary guidelines for the design and construction of the drainage system. These publications have no established order of precedence.

**TABLE 2
REFERENCES FOR DRAINAGE**

Author or Agency	Title
SHA	Standard Specifications for Construction and Materials for items identified as Reference in Attachment B of Part 3-Design Requirements
SHA	Book of Standard for Highways, Incidental Structures and Traffic Control Applications for items identified as Reference in Attachment B of Part 3-Design Requirements
SHA	"Guidelines for Preparing Stormwater Management Concept Reports", April 2003 draft.
SHA/MDE	"Stormwater Quality Management Banking Agreement" dated June 2, 1992, and amended March 1, 1994 and August 2003.
SHA	"ICC Water Quality Bank Summary and Definitions", December 2005
SHA	Grass Channel Credit Paper
SHA	"SWM Concept Report for ICC from I-370 to MD 97"
Coastal Resources	Memorandum, Subject: Resident Fish Speeds, dated February 1, 2006
SHA	Contract A – ICC Existing Inlet Survey
Montgomery County Maryland	"Interim Environmental Guidelines for Culvert Design" dated April 1998.
SHA	Contract A-ICC Existing Inlet Survey
SHA	Stormwater Management Criteria for the ICC, October 6, 2003
SHA	Drainage Design Scope Clarification-Draft February 2, 2004
SHA	ICC Linear SWM Concept for Montgomery County Special Protection Areas

3.0 REQUIREMENTS

3.1 SURFACE STORM DRAINAGE DESIGN, SUBMITTALS AND APPROVALS



The Design-Builder shall design all surface drainage conveyances including but not limited to open channels, inlets, closed storm drainage systems, cross culverts and entrance driveway pipes. The drainage design, in report form as indicated herein, shall be submitted to the Administration for review and concurrence prior to construction.

Waterway Construction (COMAR 26.17.04) review and approval is required for a number of cross culverts on the Project. Submittals for MDE approval shall be delivered to the Administration for review and coordination with MDE. The Administration has established a review and approval process with MDE for the ICC. Under that process, the Administration will review and comment on the Design-Builder's plans and, once satisfied that the plans will meet MDE requirements, the Administration will coordinate with MDE to obtain formal approval of the Design-Builder's Waterway Construction plans and calculations.

3.2 SURFACE DRAINAGE DESIGN - GENERAL REQUIREMENTS

All drainage design shall be performed in accordance with the following criteria and regulations:

- A) Surface drain ditches receiving roadway runoff shall be designed to meet Grass Channel Credit requirements, Section 5.5 of MDE's 2000 Maryland Stormwater Design Manual, to the extent practicable, as required to meet Project stormwater management water quality control needs.
- B) The design and construction of the drainage system shall include the repair and/or replacement of unstable or deteriorating outfalls, inlets, manholes, cross culverts or pipes, or other drainage structures, clean-out of existing clogged inlets, as well as replacement of any existing brick drainage structures regardless of condition within the Project limits. For information about known inlets in the Project vicinity, including as-built construction materials and depth to inside bottom from top of grate, refer to Part 7-Engineering Data. Design shall also include the repair of existing outfalls and the replacement of adversely sloped and level (zero gradient) pipes to remove adverse slopes and provide positive drainage.
- C) The drainage design shall provide positive drainage flow in all open and closed systems. The Design-Builder shall provide completed designs for all temporary and permanent pipe systems and obtain Administration approval prior to their construction.
- D) The Design-Builder shall not construct Work so as to trap water along any section. If during design or construction an area of the Project is identified as not having positive drainage in pre-construction conditions, the Design-Builder shall provide adequate measures to ensure positive drainage after construction.
- E) The Design-Builder shall provide adequate connections to maintain all existing drainage systems. Provisions shall be made to ensure that adequate drainage is provided during interim paving operations (e.g., constructing asphalt berms to divert flow from base course paving to storm drains in closed sections or other precautions as necessary).

3.3 SURFACE DRAINAGE DESIGN - SPECIFIC CRITERIA

This section contains criteria that are in addition to that contained under Drainage Design General Requirements. Where conflicts arise between these Specific Criteria and those contained in the General Requirements, these Specific Criteria will have precedence.

3.3.1 Cross Culverts

Refer to Structures Performance Specification, Section 3.10, and Environmental Performance Specification, Section 3.3.6.3, for additional cross culvert design requirements.

- A) Discharges for appropriate return period storms for cross culverts shall be calculated using USDA, SCS TR-55 and TR-20 hydrology models unless the drainage area exceeds 200 acres, then GIS Hydro is added as an acceptable model. For storm drain design, procedures found in the SHA Highway Drainage Manual shall be used. Floodplain modeling shall be performed with HEC-RAS.
- B) The 100 year headwater pool at new culverts shall remain within the right-of-way or easements, or the 100-year storm headwater elevation for the proposed conditions shall be at or below the existing 100-year water surface elevation.
- C) Wildlife passage accommodation at drainage cross culverts: A number of wildlife crossing locations have been identified in the Project. Anticipated culvert crossing locations and wildlife accommodation requirements are listed in Table 4. Wildlife crossing culverts shall meet any hydrologic and hydraulic requirements if at a stream crossing, as well as the applicable wildlife crossing criteria found in the Environmental Performance Specifications.

Table 4 is a list of anticipated major drainage cross culverts to be constructed within the Project and subject to MDE Waterway Construction Permits. Concept data for these crossings that contain site restrictions and other commitments are included in the RFP. This list is based on an alignment developed during conceptual studies and may vary according to the final documents developed by the Design-Builder. If the Design-Builder changes the following crossings list, the proposed changes shall be submitted in writing to the Administration. The Administration may then develop appropriate site specific requirements beyond those provided by the Design-Builder, to be used in the design of the crossing.

Centerline Station	Watershed	Deer*	Small Mammals*	Fish Passage Required	Comments
ICC Mainline					
112+78	Rock Creek		Yes	Yes	
615+50 I-370 Ramp F	Rock Creek		Yes	Yes	
123+84	Rock Creek			Yes	
129+77	Rock Creek			Yes	
150+00	Rock Creek	Yes		Yes	Major Crossing 1-1
162+62	Rock Creek			Yes	
173+30	Rock Creek	Yes		Yes	Major Crossing 1-2
207+01	Rock Creek			Yes	

275+47	Rock Creek	Yes		Yes	
300+70	Rock Creek		Yes	No	
312+50	Rock Creek	Yes		Yes	
313+89	Rock Creek			No	
358+38	Rock Creek		Yes	Yes	
366+33	Rock Creek			No	
377+35	Rock Creek			No	
110+24 Overhill Road	Rock Creek			No	
46+54 MD 97 Ramp C	Northwest Branch			No	
415+00	Northwest Branch			No	

* Small Mammal Passage accommodation may be within hydraulic structures if a shelf above the 2 yr normal flow depth is included, or may be a separate 72" pipe or equivalent structure. Deer passage shall be accommodated in separate structures from hydraulic crossings carrying baseflow, and may provide flood relief for storms in greater than the 2-year return period event. Stationing for these culverts is approximate.

- D) Where fish passage is required, culverts less than 72 inches in diameter shall be constructed with inverts depressed a minimum of 1 foot below the stream invert and culverts 72 inches or greater and box culverts (excluding those not for the purpose of hydraulic crossings) shall be constructed with inverts depressed a minimum of 2 feet below the stream invert to allow for natural sedimentation of the culvert bottom. The effects of invert depression on culvert hydraulic performance shall be accommodated and incorporated into design.
- E) Cross culvert design shall address fish passage in locations designated in Table 4. Fish passage design shall accommodate elements of fish biology including swim speed for species found in reference titled Resident Fish Speeds. Culvert design shall be in accordance with Interim Environmental Guidelines for Culvert Design.

3.3.2 Roadway Drainage Design

- A) The flow spread in a closed section for a 2 year storm event shall not exceed 8 ft. and in no case cover more than one half of any travel lane. Exceptions to these criteria

will be considered on a case by case basis.

- B) The maximum flow across entrances shall be 1 cfs for the 2-year storm event. Maximum flow from the end of curb and gutter shall be 0.5 cfs for the 2-year storm event.
- C) The side ditch criteria with respect to holding the 10-year water surface elevation at least 9 inches below the shoulder edge, as stated in the Highway Drainage Manual, Part I, Chapter 3 Open Drainage, Section A Ditches, Gutters and Channels, item number 6, paragraph 2 and item number 7, is waived for the ICC. The side ditch capacity shall remain based on the 10-year storm; however the 10-year flow shall not cause flooding of the roadway or shoulder. The 10-year flow in side and median ditches shall not wet guardrail posts.
- D) No inlet grates, manhole covers or other drainage structure tops shall be constructed within the travel lanes of the mainline ICC.
- E) Roadway inlets and drainage structures shall conform to the Administration's "Book of Standards for Highways, Incidental Structures and Traffic Control Applications" or approved equal(s). Type COG or COS are preferred. Other inlets and non-standard structures proposed shall receive concurrence from the Administration prior to construction. When grate inlets are used within the roadway section and where the roadway is subject to pedestrian or bicycle traffic, inlets shall be fitted with ADA compliant grates such as WR or curved vane grate.
- F) No break in curb, such as curb cuts, will be allowed for drainage purposes without concurrence from the Administration prior to construction.
- G) The Design-Builder shall prepare and provide storm drain profiles of all new storm drains and connections to existing storm drains, as outlined in SHA's Highway Drainage Manual, for the Administration's consultation and written comment prior to construction.
- H) Ditches shall be designed with minimum 0.5% slope to ensure positive drainage flow. Standing water will not be acceptable, except for stormwater management. Ditch inverts in cut shall be scarified prior to placement of topsoil to maximize infiltration potential.
- I) Ditch surface lining shall be Soil Stabilization Matting (SSM) rather than riprap, wherever possible. Type A matting is temporary matting and shall be used in ditches with 10-year storm discharge velocity of less than 5 fps or for slope stabilization. Type B matting is permanent matting and shall be used in ditches with 10-year storm discharge velocities ranging from 5 fps to 8.5 fps (refer to the Administration's "Standard Specifications for Construction and Materials").
- J) Riprap shall only be used as a ditch lining where SSM cannot be used or to provide velocity attenuation (e.g., outfall protection). Concrete lined ditches and concrete slope or channel protection will not be allowed because of long term maintenance concerns.
- K) Design of side ditches in fill/embankment greater than 5 feet in height should consider impervious liners or subsurface drainage controls at some depth below the topsoil so as to have sufficient material for vegetative growth but not to infiltrate surface water into fill material that could potentially cause fill slope failure.
- L) Effective side slopes within or adjacent to wetland areas and wetland buffers shall be

2:1 or steeper to minimize wetland impacts. Refer to Geotechnical Performance Specifications for slope design and construction requirements, and the Environmental Performance Specification for permitted wetland impacts and wetland avoidance..

- M) All existing pipes and drainage structures to be used in the Final Design shall be inspected and assessed for structural integrity and hydraulic capacity by the Design-Builder. Existing brick drainage structures shall be replaced with Administration approved cast-in-place or precast concrete structures (See Table 3). Inspection reports shall be compiled and submitted for concurrence and shall include photographs and a written report describing the structural integrity of the drainage structure. Those existing pipes and drainage structures failing to meet structural integrity requirements or those not having positive drainage shall be replaced.
- N) Conversion of existing drainage structures into junction boxes within the roadway shall not be incorporated into the design without the Administration's consultation and written comment prior to construction. Inspection report data shall be provided for the Administration's review and written comment.
- O) As a condition of Final Completion, all storm drains shall be cleaned to the satisfaction of the Administration at no additional cost to the Administration.
- P) Pipes shall conform to the following service life requirements:
 - 1) Culverts
 - a) Mainline Roadway-100 years;
 - b) Roadway pavement width greater than 27 feet or cover greater than 10 feet-75 years; and
 - c) Roadway pavement width 27 feet or less-50 years.
 - 2) Storm Drain
 - a) Beneath the Roadway Pavement-See Culvert criteria above; and
 - b) Outside the Roadway Pavement-50 years.
 - 3) Underground Storage(Stormwater Management)
 - a) Beneath the Roadway Pavement-See Culvert criteria above;
 - b) Outside the Roadway Pavement-50 years; and
 - c) Bottomless storage chambers shall not be used for underground storage.
- Q) The assumed service life for concrete pipe shall be 100 years. The service life for metal pipes shall be determined using Tables 6.2 and 6.3 from the "State of Florida, Department of Transportation, Drainage Manual, January 2006". The assumed service life for plastic pipe shall be 50 years.
- R) Horizontal Elliptical Reinforced Concrete Pipe (HERCP) may be specified when necessary to meet the minimum cover requirements as set forth in the Highway Drainage Manual.
- S) The pipe material shall conform to Table 5:

**TABLE 5
PIPE SELECTION CRITERIA**

Abbreviation	Description	Specification	Limitations	Soil and Water Range of Application	Backfill Material
CSP	Corrugated Steel Pipe - Aluminized Type 2	M 36, M274	15" to 60" - 2 2/3" x 1/2" Corrugations 54" to 60" - 3" x 1" Corrugations	Minimum resistivity shall be above 1500 ohm-cm. Minimum gauge is 14. Metal pipe shall not be used for culverts with baseflow because of varied bedloads.	Minimum Select Borrow for pipes within the roadway pavement. Minimum Common Borrow for all other pipe. Backfill envelope shall extend from 6" below pipe to 9" above pipe.
CSPA	Corrugated Steel Pipe Arch - Aluminized Type 2	M 36, M274	17" x 13" to 71" x 47" - 2 2/3" x 1/2" Corrugations 60" x 46" to 71" x 47" - 3" x 1" Corrugations		
SPP	Structural Steel Plate Pipe	M 167	60" to 96" diameter		
SPPA	Structural Steel Plate Pipe Arch	M 167	60" to 96" diameter equivalent.		
SRP	Steel Spiral Rib Pipe - Aluminized Type 2	M 36, M274	18" to 60" - 3/4" x 3/4" x 7 1/2" Corrugations		
SRPA	Steel Spiral Rib Pipe-Arch - Aluminized Type 2	M 36, M274	21" x 15" to 71" x 47" - 3/4" x 3/4" x 7 1/2" Corrugations		
PCSP	Corrugated Steel Pipe, Polymer Precoated	M 245	18" to 60" Not for use as culvert.	None	Minimum Selected Backfill for pipe within the roadway pavement. Minimum Select Borrow for pipe outside the roadway pavement. Backfill envelope shall extend from 6" below pipe to 9" above pipe.
CPP-S	Corrugated Polyethylene Pipe - Type 'S' (Smooth Interior)	M 294	18" to 48" diam. - 2' minimum cover. 6" min diam. for use as SWM underdrain.		
PPWP	Polyvinyl Chloride Profile Wall Pipe	M 304	18" to 36" - 2' minimum cover.		
PVCP-P	Polyvinyl Chloride Pipe - Perforated	M 278	4" to 12", underdrains		
PVCP	Polyvinyl Chloride Pipe	M 278	4" to 12", underdrain outlets	Chlorides more than 400 ppm and pH<4 required Class V minimum	Minimum Common Borrow for all pipe. Backfill envelope shall extend 6" below pipe to 9" above pipe.
HERCP	Horizontal Elliptical Reinforced Concrete Pipe	M 207	23" x 14" to 53" x 34", Class HE-IV minimum		
RCP	Reinforced Concrete Pipe	M 170	15" to 84" - Class IV minimum *		
RCPP	Reinforced Concrete Low- Head Pressure Pipe	C 361	Code 378 Spillways		
Box Culvert	Box Culvert	M 259, M 219	Concurrence from the Administration required prior to final design.		

Notes:

- 1.) Pipes greater than 84" diameter (or equivalent) require concurrence from the Administration prior to final design.
- 2.) Metal pipes greater than 96" (or equivalent) diameter require concurrence from the Administration prior to final design.
- 3.) All pipes qualifying as "Small Structures" require concurrence from the Administration prior to final design.
- 4.) Where unsuitable pipe foundation material exists, a minimum of 6" of selected backfill bedding shall be used.
- 5.) Borrow: All borrow excavation shall be a soil aggregate mixture and shall have a maximum dry density and optimum moisture content as specified in AASHTO T180, Method C, unless the material has more than 35 percent retained on the No. 4 sieve, in which case Method D shall be used.
- 6.) Common Borrow: Common Borrow shall have a maximum dry density of not less than 100 lb./cf.
- 7.) Select Borrow: Select Borrow shall conform to A-2, A-3, or A-2-4 material. The maximum dry density shall be a minimum of 105 lbs./cf.
- 8.) Select Backfill: Select backfill is classified as No. 57 aggregate or Crushed Run Aggregate CR-6.
- 9.) Maximum Cover Requirements:

TABLE 5
PIPE SELECTION CRITERIA

Abbreviation	Description	Specification	Limitations	Soil and Water Range of Application	Backfill Material
10.) Concrete Pipe: Consult appropriate height of fill tables, "SHA Highway Drainage Manual". 11.) Metal Pipe: Consult appropriate height of fill tables, "SHA Highway Drainage Manual", For special designs use "AASHTO, Standard Specifications for Highway Bridges", Section 12. 12.) Plastic Pipe: Use "AASHTO, Standard Specifications for Highway Bridges", Section 18.					

- T) Unsuitable pipe foundation material shall be replaced with No. 57 aggregate or crushed run aggregate CR-6. Pipe backfill shall be earth free from large lumps, clods, and rocks and shall be placed along the side of the pipe for the full width of the trench in layers not exceeding 6 inches uncompacted depth. Compaction shall conform to Roadway and Geotechnical Performance Specification requirements. Each layer shall be compacted simultaneously on both sides of the pipe. This method of filling and compacting shall continue until the backfill is completed to a minimum depth of 9 inches above the top of pipe. The Design-Builder shall protect all pipe from damage due to construction equipment or other vehicular traffic passing over the pipe. Backfill may be placed immediately after laying the pipe, provided that all joints have been sealed as specified.
- U) Pipes shall be laid with hubs up grade. A single lay hole through the shell of the pipe is permitted for installation with a lifting device. The lay hole shall be cast in the pipe during fabrication or cored without damaging any reinforcement, and plugged after installation with mortar, rubber plug or other means.
- V) All pipe joints shall be sealed in a manner appropriate to the type of pipe material. Reinforced Concrete Pipe shall be sealed with rubber type gaskets (circular pipe) conforming to AASHTO M198 or resilient type material (elliptical pipe). Metal pipe joints shall be sealed with rubber gaskets and coupling bands conforming to AASHTO M36. Plastic Pipe joints shall be integral bell and spigot with rubber or neoprene gaskets conforming to AASHTO F477..
- W) Pipe connections may be either prefabricated or constructed in the field. Corrugated pipe sections shall be butted together and sections joined with a band in accordance with manufacturer's recommendations to make a soiltight seal. Field connections for concrete or corrugated metal pipes shall employ concrete collars or welded connections for metal pipes may be substituted for concrete collars.
- X) When a pipe is to be laid on existing ground, on or under a fill, embankment shall be constructed to a height of at least 9 inches, but not more than 3 feet above the proposed top of pipe. The trench shall then be excavated to receive the pipe. The width of the trench shall be sufficient to permit thorough tamping of the backfill under the haunches and around the pipe. This width shall be twice the outside diameter of the pipe of the outside diameter plus 18 inches, whichever is less.
- Y) Underground drainage structures shall be completed before the roadway surface is placed. Manholes, catch basins, and inlets shall not be completed to final grade until the grading has been finished and necessary arrangements have been made to ensure suitable connections and tie-ins at proper grade and alignment with pavement, gutters and curbs.
- Z) Castings such as frames, grates, and covers for inlets and manholes (except PE

manholes) shall be set in full beds of mortar and rigidly secured in place to proper grade and alignment.

- AA) Pipe connections between inlet and outlet pipes at drainage structures shall be set or cut flush with the inside faces of the structures and shall extend to sufficient distance beyond the outside faces of these walls to provide ample room for making proper connections. Joints between pipes and structure walls shall be completely free and neatly closed with mortar.
- BB) Drainage structures having two or more pipes shall have channeled inverts.
- CC) Inlets and manholes shall contain two 8 inch diameter block-outs for underdrains. The drainage structure shall be backfilled with No. 57 aggregate for a width of 1.5 feet outside the structure and extend from the bottom of the structure to the subgrade.

3.4 GROUNDWATER

The Design-Builder shall develop a Spill Prevention Control and Countermeasure (SPCC) plan to prevent spilled chemicals from entering the groundwater or surface water by direct runoff into a stormdrain or stream or by infiltration into the subsurface during construction. The SPCC shall be in accordance with US EPA requirements found in 40 CFR 112. The Design-Builder shall make every effort to remediate spills before they can infiltrate into the groundwater system. Furthermore, as part of any spill remediation plan, contaminated soils shall be removed, disposed of properly with appropriate documentation, and replaced with clean fill. In case of a spill, the Administration and MDE shall be notified immediately.

3.5 FLOODPLAIN COORDINATION

The Design-Builder shall be responsible for coordinating analysis of applicable drainage crossings with FEMA and the Administration. Floodplain crossing requirements can be found in Structures Performance Specifications.

3.6 STORMWATER MANAGEMENT DESIGN AND APPROVALS

The Design-Builder shall coordinate all reviews and submissions with the Administration. The Administration has established a review and approval process with MDE for the ICC. Under that process, the Administration will review and comment on the Design-Builder's plans and, once satisfied that the plans will meet MDE requirements, the Administration will coordinate with MDE to obtain formal approval of the Design-Builder's Stormwater Management (SWM) plans and calculations. MDE will formally review the methodology in the Design-Builder's Preliminary SWM Report for critical path Earth Disturbance Areas (EDAs, see below for more information on EDAs) and issue a Letter of Intent to issue a formal approval for those areas based on this information. Once the Letter of Intent is issued by MDE, the Design-Builder shall be responsible for finalizing the SWM design. Pieces of the Work may be designed, submitted for review, and approved to address anticipated EDAs or phases required to complete the Project.

Once the MDE review process is complete, the Design-Builder shall submit 3 sets of the approved plans and reports to the Administration. The Design-Builder shall ensure that copies of the most current approved plans are available to all personnel involved in the construction and inspection of the Project.

Maryland Department of the Environment (MDE) SWM Review and Approval:

- A) The Design-Builder shall be responsible for demonstrating to the Administration that all of the stormwater management needs of the Project can be met within the right-of-

- way shown on the RFP Plates. The final design of each section or phase shall be acceptable to both the Administration and MDE prior to construction.
- B) A Pre-Permitting meeting will be held by the Administration once Limited Notice to Proceed for the Project has been issued. This meeting will be scheduled by the Administration upon request by the Design-Builder and will include the Design-Builder's Lead H&H Engineer, Construction Manager, Design Manager, Erosion and Sediment Control Manager (ESCM), and representatives from the Administration's Environmental Management Team (EMT), Independent Environmental Monitor (IEM) and MDE. The purpose of the meeting will be to preview and discuss stormwater management and erosion and sediment control concepts to be developed by the Design-Builder, submission schedules proposed by the Design-Builder, permitting timeframes, submission requirements and the Administration's quality expectations.
- C) A Preliminary SWM Report that addresses the earth disturbance areas (EDA) required for initial construction shall be prepared by the Design Builder and submitted to the Administration for review and comment. Once comments have successfully resolved and incorporated by the Design-Builder, the Preliminary SWM Report will be forwarded to the MDE for formal approval. Deviations from the MDE approve Preliminary SWM Report by the Design-Builder are the sole responsibility of the Design-Builder. The Administration will not pay for any additional design, MDE review coordination, construction or other costs incurred due to deviations from the Preliminary SWM Report. The Design-Builder shall supplement the Preliminary SWM Report as necessary to address subsequent EDAs required to continue construction.
- D) Structural stormwater management facility locations have been offered for consideration by the Administration as shown on the applicable RFP Plans by "SWM". The Design-Builder may identify other locations within the Project right of way such as within interchange loops, gore areas, extra land or other areas as appropriate and explore the feasibility of using those areas with the Administration's consultation and written comment. If the Design-Builder chooses locations for stormwater management facilities outside of Administration right-of-way, approval from the Administration shall be obtained during Definitive Design of SWM.
- E) The Preliminary SWM Report shall address SWM for each location where discharge leaves the Limit of Disturbance. The Letter of Intent from MDE will be issued based upon MDE's acceptance of the Preliminary Stormwater Management Report, and the use of SWM facilities described therein. Various types of SWM facilities may be used, but they shall meet all requirements of the 2000 Maryland Stormwater Design Manual and subsequent changes with concurrence from the Administration and formal approval from MDE prior to construction.

3.7 STORMWATER MANAGEMENT GENERAL REQUIREMENTS

Stormwater management (SWM) Best Management Practices (BMPs) shall conform to MDE's 2000 *Maryland Stormwater Design Manual* and *Stormwater Management Guidelines for State and Federal Projects*, and the following ICC commitments with regard to SWM:

- A) In calculating Water Quality Volume using the 2000 *Maryland Stormwater Design Manual*, the Design-Builder shall replace "P = rainfall depth in inches and is equal to 1.0" in the Eastern rainfall Zone and 0.9" in the Western Rainfall Zone (Fig. 2.1)" with "P = rainfall depth in inches and is equal to 1.5" for the ICC" in Table 2.1, and

throughout the manual.

- B) Within the Montgomery County Special Protection Areas (SPAs) and Use III watersheds, approximately between MD 115 and MD 97, in addition to MDE Grass Channel Credit criteria as found in Section 5.5 of the *2000 Maryland Stormwater Design Manual*, linear filtering devices shall be employed in outside and median ditches in accordance with “ICC Linear Stormwater Management Concept”.
- C) The Design-Builder shall capture and provide water quality and quantity control for runoff from roadway and bridge decks within the SPA through methods acceptable to the Administration and MDE.
- D) The Design-Builder shall demonstrate compliance with MDE’s 12-hour Channel Protection Volume (Cpv) requirements in accordance with Table 2.1, 2000 Maryland Stormwater Design Manual. Cpv storage shall be provided either in dry surface ponds or dry underground chambers depending on available right of way and with concurrence from the Administration prior to construction (refer to Table 6).
- E) Waivers of or variances from strict adherence with MDE requirements shall be evaluated on a case by case basis. No waivers from MDE’s Cpv requirements shall be granted unless a stable outfall is documented.

3.7.2 BMP Selection

The Design-Builder shall present SWM facility types during Definitive Design for the Administration’s consultation and written comment prior to advancing SWM design. The Administration will use the following criteria in evaluating proposed facilities:

- A) The best fit given the site context and minimization of footprint shall be considered.
- B) Grass Channels (see Grass Channel Credit paper included in this advertisement package for design guidance) and other non-structural practices shall be considered first when feasible.
- C) BMPs requiring lower maintenance shall be considered first. Potential maintenance needs shall be considered when designing SWM facilities.
- D) Maintenance access and frequency.

3.7.3 ICC Water Quality Bank

Impervious surface created for the Project shall be accounted from a stormwater management perspective in the ICC Water Quality Bank. The Project falls primarily within the Rock Creek Watershed, and as a result, must demonstrate a “0” or positive balance of impervious surface treated at the completion of the Project. The aggregate amount of new impervious surface added to the Project shall be treated for water quality according to the above-mentioned regulations and/or guidelines, and the treatment provided shall be tallied according to:

- A) MDE/SHA Stormwater Quality Management Banking Agreement dated June 2, 1992, and amended March 1, 1994, with revisions as described below:
 - 1) 100% credit for on-site (SHA) untreated impervious with any MDE approved BMP.
 - 2) Off-site (non-SHA) untreated impervious areas may be eligible for 80% credit with MDE concurrence.
 - 3) Non-structural BMPs qualify for only Project credit, not bank credit. Excess

grass channel credit cannot be applied to the bank.

- 4) Pavement removal with soil amendments to promote infiltration will be considered as redevelopment and will receive 80% credit. If it is demonstrated that the pavement removal is solely for water quality treatment purposes, then 100% credit will be applied.
- B) The ICC Water Quality Bank Summary and Definitions.

3.7.4 SWM Specific Engineering Criteria

- A) Proposed stormwater management facilities shall have coordinated detailing throughout the Project and they shall be worked into the concepts for the corridor landscaping. This means that facility types, outfall structure designs, detailing, colors, planting palette, landforms, surface area shapes and fencing (if required) shall be consistent. Refer to Planting and Landscape Architectural Performance Specifications for further information regarding landscaping design and SWM.
- B) All stormwater management ponds and constructed wetlands for stormwater treatment shall be located a minimum distance of 15 feet from the edge of pavement. This distance shall be measured from the 2-year water surface elevation limit at its closest point to the roadway. Though preferred, this criterion does not apply to existing SWM facilities within the Project.
- C) Design of linear SWM in fill/embankment greater than 5 feet in height should consider impervious liners or subsurface drainage controls at some depth below the topsoil so as to have sufficient material for vegetative growth but not to infiltrate surface water into fill material that could potentially cause fill slope failure.
- D) Riser structures and pipe outfall systems shall be concrete. Concrete structures that are visible shall meet the requirements set forth in the Planting and Landscape Architectural Performance Specifications.
- E) Concrete pipe used for stormwater management pond outfalls shall meet the requirements of ASTM C-361. Riser structures shall be set in embankments or placed so they are easily accessed for maintenance. Riser structures shall also be placed so they are visually unobtrusive. Risers shall be cast in place or precast as one unit. Refer to the 2000 Maryland Stormwater Design Manual for additional SWM specifications.
- F) Underground SWM structures anticipated to be used as shown in the Roadway Concept Plans or elsewhere on the Project:
 - 1) Shall not include manholes or other access structures within roadway paving section;
 - 2) Shall address groundwater recharge (Rev), water quality volume (WQv), and Channel Protection Volume (Cpv) as appropriate..
 - 3) Shall include safe, stable, long term maintenance access from off of the roadway shoulder including sufficient room for vehicular pull-off, with concurrence from the Administration prior to final design;
 - 4) That are designed to address water quality shall consider filter media design life/maintenance frequency and degree of maintenance difficulty, and selection of the device with concurrence from the Administration and comments satisfactorily addressed prior to Final Design. All water quality devices,

- proprietary or otherwise, must either be included in the 2000 Maryland Stormwater Design Manual or shall be approved by MDE in writing prior to use;
- 5) Shall meet design life requirements of pipes (reference Section 3.3.2 of these Specifications);
 - 6) That require vacuum truck maintenance access shall incorporate access manholes on 100 foot maximum center spacing; and
 - 7) Underground stormwater management facility needs are anticipated in the locations shown in the Roadway Concept Plans.
-
- G) The finish and appearance of trash racks where required on stormwater management pond risers visible from the roadway or adjacent communities shall be consistent with roadway aesthetic requirements found in the Planting and Landscape Architectural Performance Specifications. Trash racks not visible from the roadway or adjacent communities shall be hot-dipped galvanized metal, M 111-80. Trash racks shall be designed as flat-fronted cages that stand away from and completely enclose the riser opening(s). Ends of the steel rods shall be attached to a frame that attaches to the structure. Trash rack designs shall use similar detailing for all openings on the structure. Trash rack detailing shall be similar throughout the Project.
 - H) Open tops on outfall structures are not preferred. If they are used, a trash rack shall be designed that is not placed horizontally but is placed at an angle of not less than 1" vertical for every 12" horizontal in order to reduce the potential for clogging.
 - I) Low flow, perforated pipes shall be wrapped with galvanized wire mesh rather than geotextile. Pipes extending into ponds shall be anchored against flotation.
 - J) SWM embankments shall be planted in accordance with the Planting and Landscape Architectural Performance Specifications. No woody material shall be planted on pond fill embankments, within 15 feet of the toe of pond embankments, or within 25 feet of pond outfall structures. Material for the SWM embankments is required to

conform to NRCS Pond Code MD-378 as found in the 2000 Maryland Stormwater Design Manual, Appendix B1, embankment clay core and cut-off trench shall conform to A-2-7, A-7-2, A-4-7, A-7-4, or A-7. Maximum particle size shall be three inches.

- K) The maximum grade allowed for side slopes at stormwater management facilities shall be in conformance with Planting and Landscape Architectural Performance Specifications.
- L) Filter diaphragms shall be used for embankment seepage control in place of anti-seep collars within the SWM embankment when classified as embankment ponds under the 2000 Maryland Stormwater Design Manual, Appendix B1. The design criteria for filter diaphragms shall be as outlined in the 2000 Maryland Stormwater Design Manual, Appendix B1.
- M) A BMP number shall be obtained from the Administration for each structural BMP constructed on the Project.
- N) A minimum 15 foot clear zone shall be provided within the Project right-of-way at the toe of SWM pond embankments to keep woody vegetation clear.
- O) Fencing of SWM facilities shall meet requirements set forth in the Planting and Landscape Architectural Performance Specification.

3.7.5 SWM As-Built Certifications

This Work shall consist of inspecting stormwater management (SWM) facilities during various stages of construction and providing documentation to the Administration that certifies SWM facilities have been constructed as specified in the Contract Documents, including certification that the constructed SWM facilities meet the functionality as designed.

3.7.5.1 As-Built (AB) Inspector

The AB Inspector shall be a licensed Professional Engineer or Land Surveyor in the State of Maryland with experience in stormwater management design and construction.

3.7.5.2 As-Built Certification Package

The as-built certification package shall consist of photographs, completed as-built checklists for each SWM facility, completed as-built certification forms for each SWM facility, material testing reports for any soil, a copy of green-line revision plans for SWM facilities that include as-built survey information, a copy of completed planting checklists, and turf inspection data for SWM facilities and drainage conveyances areas (such as ditches and swales). Information about the person(s) that perform the plant and turf inspections shall be part of the as-built certification package and shall include, but not be limited to, name of person(s), employer name, brief description of related work history, contact information, and anticipated dates for plant and turf establishment inspections. The Design-Builder shall provide to the Administration two hard-copies and one digital copy in PDF format of the as-built certification package.

The AB Inspector shall perform minimum inspections for SWM facilities as follows:

- A) Ponds:
 - 1) Upon completion of excavation to sub-foundation and when required, installation of structural supports or reinforcement for structures, including, but not limited to:
 - a) Core trenches for structural embankments;

- b) Inlet (riser) and outlet structures, anti-seep collars or diaphragms, and watertight connections on pipes; and
 - c) Trenches for enclosed storm drainage facilities.
- 2) During placement of structural fill, concrete, and installation of piping and catchbasins;
- 3) During backfill of foundations and trenches;
- 4) During embankment construction; and
- 5) Upon completion of final grading and establishment of permanent stabilization.
- B) Wetlands. Refer to stages specified for pond construction. Additional inspections include:
 - 1) During and after wetland area planting; and
 - 2) During the second growing season to verify a vegetation survival rate of no less than fifty percent (50%).
- C) Infiltration Trenches:
 - 1) During excavation to subgrade;
 - 2) During placement and backfill of underdrain systems and observations wells;
 - 3) During placement of geotextile and all filter media;
 - 4) During construction of appurtenant conveyance systems such as diversion structures, pre-filters and filters, inlets, outlets, and flow distribution structures; and
 - 5) Upon completion of final grading and establishment of permanent stabilization.
- D) Infiltration Basins. Refer to stages specified for pond construction and add:
 - 1) During placement and backfill of underdrain systems.
- E) Filtering Systems. Filtering systems include bioretention, sand filters, organic filters, bio-filters, and dry swales:
 - 1) During excavation to subgrade;
 - 2) During placement and backfill of underdrain systems;
 - 3) During placement of geotextile and all filter media;
 - 4) During construction of appurtenant conveyance systems such as flow diversion structures, pre-filters and filters, inlets, outlets, orifices, and flow distribution structures; and
 - 5) Upon completion of final grading and establishment of permanent stabilization.
- F) Open Channel Systems. Open channel systems include wet swales and grass channels:
 - 1) During excavation to subgrade;
 - 2) During installation of diaphragms, check dams, or weirs; and
 - 3) Upon completion of final grading and establishment of permanent stabilization.
- G) Non-Structural Practices; and

- H) Upon completion of final grading and after the establishment of permanent stabilization.

The checklist for each SWM facility shall be completed in its entirety at the appropriate stages of construction as specified in the Contract Documents. The as-built certification shall be signed and dated by the AB Inspector upon completion of all SWM facility checklists.

3.7.5.3 As-Built Survey, Computations and Green-Line Drawings

Upon completion of the final grade and stabilization at each SWM facility, the Design-Builder shall survey each SWM facility, including contours, inflow and outflow ditches, limits of riprap, emergency spillway(s), outfall structure(s) (including elevations and dimensions at top, all orifices, weirs and openings), and all other pertinent features in and around the facility.

The constructed elevations shall be within 3 inches of design elevations. Elevation variance greater than 3 inches shall be corrected by the Design-Builder to meet the acceptable tolerance limits or the Design-Builder shall provide computations for the volumes, discharges, stage-storages, freeboard, detention times and other parameters deemed necessary by the Design-Builder or the Administration that demonstrate that the SWM facility meets the designed parameters. The Design-Builder shall resurvey any corrected areas.

3.7.5.4 Submission to and Acceptance by the Administration

The Design-Builder shall submit the completed as-built certification package to the Administration for final acceptance.

3.8 EROSION AND SEDIMENT CONTROL (ESC) DESIGN AND APPROVALS

The Design-Builder shall prepare and submit an Erosion and Sediment Control plan for the Project to the Administration for review, comment and coordination with MDE. The Administration has established a review and approval process with MDE for the ICC. Under that process, the Administration will review and comment on the Design-Builder's plans and, once satisfied that the plans will meet MDE requirements, the Administration will coordinate with MDE to obtain formal approval of the Design-Builder's Erosion and Sediment Control plans and calculations.

The Design-Builder shall assign an employee to serve in the capacity of primary Erosion and Sediment Control Manager (ESCM). The ESCM and the Construction Manager shall have successfully completed the Administration's Erosion and Sediment Control Certification Training for Contractors and Inspectors and obtained a completion certificate (Yellow Card) prior to beginning earth disturbance activities on the Project. This certification must be current at all times. If the certification is expired or revoked for either person, the Design-Builder shall immediately replace the personnel with appropriately certified persons acceptable to the Administration.

3.8.1 Erosion and Sediment Control Program

The Design-Builder shall be responsible for developing an ESC Program for earth disturbing activities and restoration of areas used for temporary impacts. Elements of the ESC Program shall include but not be limited to:

- A) ESC Plans: Plans meeting the requirements of MDE's Erosion and Sediment Control Guidelines for State and Federal Projects shall be submitted to the Administration for review, comment and coordination with MDE. The Design-Builder shall be responsible for addressing any comments supplied by the Administration. Upon approval of ESC plans by the Administration, the Administration shall submit the final plans to MDE for formal approval.

- B) A Pre-Permitting meeting must be scheduled as discussed under SWM Design and Approval section 3.6 above. Submittals for ESC approval shall be delivered to the Administration according to the review process for SWM approval described above under SWM Design and Approval.
- C) A written ESC Sequence of Construction, in concert with Traffic Control Plan (TCP) phasing, shall include:
 - 1) Detailed steps necessary to establish and maintain clear water diversions through or around any work area; and
 - 2) Proposers shall submit an Earth Disturbance Area (EDA) plan to demonstrate to the Administration that the proposed areas of ground disturbance will be consistent with proposed resources to grade in a timely and quality manner and, more importantly, to maintain sediment and erosion controls. An EDA is a Design-Builder defined work area within the Project limits that must be disturbed to carry out a contiguous grading operation. A grading operation is defined by the Design-Builder's ability to provide adequate resources to perform the grading in a timely manner and provide and maintain the proper erosion and sediment control measures for the duration of the earth disturbing activities and until final stabilization is accomplished. The Plan shall include a storm response plan depicting steps to be taken to assess, mobilize, and resolve ESC issues after a major storm event. Upon concurrence from the Administration that the EDA Plan is acceptable, each EDA must be substantially completed (greater than 75 percent graded and with final stabilization) before the Design-Builder can request in writing that subsequent EDA(s) can be disturbed. The Design-Builder shall not proceed if a score of less than 80 was received on the most recent quality assurance rating and until a quality assurance rating of A or B is obtained.
- D) Once the MDE review process is complete, the Design-Builder will be granted final approval from the Administration and shall submit a completed Notice of Intent (NOI) Form to MDE in accordance with the NPDES General Permit for Construction Activities.
- E) Design-Builder's Inspection and Maintenance Protocols for ESC devices, including plans for preemptive actions to address predicted severe weather events and sediment spills.
- F) Design-Builder's approach to stockpiling materials needed to perform emergency maintenance.

3.9 ESC QUALITY ASSURANCE RATINGS

ESC compliance will be monitored and surveyed during construction by the Administration/EMT (see Environmental Performance Specification) to ensure compliance with the approved ESC plan. The Design-Builder shall, after obtaining ESC approval for the earth disturbance area (EDA) required for a grading operation, demarcate limits of disturbance, wetlands and wetland buffers, floodplains, and tree protection areas, and shall proceed with clearing and grubbing of the earth disturbance area under approved ESC plans and schedules. The Administration's EMT will perform ESC surveys to ensure compliance with ESC plans at least once per calendar week, and assign one of the following ratings:

3.9.1 Rating A

The Project will receive an 'A' rating from the Administration if the score is equal to or greater than

90 on form number OOC61, ESC Field Investigation Report.

3.9.2 Rating B

The Project will receive a 'B' rating from the Administration if the score is 80.0 to 89.9 on Form OOC61, ESC Field Investigation Report.

3.9.3 Rating C

The Project will receive a 'C' rating from the Administration if the score is 70.0 to 79.9 on Form OOC61, ESC Field Investigation Report. A 'C' rating indicates that the Project is in compliance, however, deficiencies are noted and shall be corrected. Conditions for a shut down could arise quickly. If the Project receives a 'C' rating, it will be formally re-surveyed by the EMT within 72 hours.

3.9.4 Rating D

The Project will receive a 'D' rating from the Administration if the score is 60.0 to 69.9 on Form OOC61, ESC Field Investigation Report. A 'D' rating indicates that the Project is in non-compliance. All earthwork operations on the Project will be shut down by the Administration. All work efforts within Project limits shall focus on correcting ESC deficiencies. The Project will be formally re-surveyed by the EMT within 72 hours. All required corrective actions shall be completed within the 72 hour period for the Project to be upgraded to a 'B' rating. Failure to upgrade to a 'B' rating will result in the Project being rated an 'F'. ESC noncompliance triggers shutdowns (see Section 3.10 below) and liquidated damages (see Section 3.11 below).

3.9.5 Rating F

The Project will receive an 'F' rating from the Administration if the score is less than 60.0 on Form OOC61, ESC Field Investigation Report; or if the Design-Builder has not obtained all appropriate permits and approvals, demarcated limits of disturbances, wetland and wetland buffers, floodplains, and tree protection areas; or is not proceeding according to the approved ESC plan and schedules. An 'F' rating indicates that the Project is in noncompliance, and the ENTIRE Project will be shut down by the Administration until the Project receives a 'B' rating. All work efforts shall focus on correcting ESC deficiencies. The Project will be formally re-surveyed by the EMT within 72 hours of receiving an 'F' rating. ESC noncompliance triggers shutdowns (see Section 3.10 below) and liquidated damages (see Section 3.11 below).

3.10 SHUTDOWNS

When a 'C' rating is assigned to Project, the Design-Builder shall have all deficiencies corrected within 72 hours. The Project will be formally re-surveyed by the EMT at the end of this period. If it is found that the deficiencies have not been satisfactorily corrected, a 'D' rating will be assigned and all earthwork operations will be shut down until the Project receives a 'B' rating.

When a consecutive 'C' rating is assigned for other deficiencies and the original deficiencies were corrected, the Design-Builder will be alerted that the overall effort is marginal and a shut down of all earthwork operations for the Project is imminent if ESC efforts do not substantially improve within 72 hours. The Project will be formally re-surveyed by the EMT at the end of the 72 hour period. If it is found that the deficiencies have not been satisfactorily corrected or other deficiencies are identified by the EMT that result in a score of less than 80 on form number OOC61, a 'D' rating will be assigned and all earthwork operations will be shut down until the Project receives a 'B' rating.

When a disregard for correcting these deficiencies is evident, an 'F' rating will be assigned and the ENTIRE Project will be shut down until the Project receives a 'B' rating.

When degradation to a resource is imminent, or if the Design-Builder is unresponsive to to perform corrective action, the Administration may elect to have corrective actions performed by another contractor or by Administration staff. All costs associated with this corrective work will be billed to the Design-Builder.

3.11 INCENTIVE PAYMENT / LIQUIDATED DAMAGES

The Administration has included an incentive payment to be earned by the Design-Builder for exceptional erosion and sediment control performance. When an average score equal to or greater than 85 for the entire calendar quarter is assigned to the Project by the Environmental Management Team (EMT), a quarterly incentive payment will be made to the Design-Builder. No incentive will be paid for partial quarters or for quarters with less than four ESC surveys. No incentives will be paid for any quarter rated as “D” or “F” by the EMT. Measure for ESC incentive begins the month that the EMT performs their first QA oversight survey. If no rating of “D” or “F” is assigned for any quarter and the average quarterly rating for the entire Project duration is 85 or greater, a final ESC incentive payment will be made at Final Completion.

If the Project is assigned 2 consecutive quarterly ratings of “F”, the Erosion and Sediment Control Certification issued by the Administration will be revoked from both the Construction Manager and Erosion and Sediment Control Manger for a period of not less than six months and until such time that the individuals successfully complete the Administration’s Erosion and Sediment Control Certification Program again. Neither the Construction Manager nor Erosion and Sediment Control Manager will be allowed to oversee the installation and maintenance of erosion and sediment control for the period certification is revoked on any project funded by the Administration. The Design-Builder shall immediately provide appropriately certified personnel to replace the Construction Manger and Erosion and Sediment Control Manager. Work shall not commence until certified replacements are provided.

3.11.1 Incentive/Liquidated Damages Payment

The maximum cumulative ESC incentive that may be earned for the Project is \$4,000,000. The maximum quarterly ESC incentive that may be earned is \$250,000. A final incentive fee of \$1,000,000 may be earned, less any quarterly incentive payments earned for contract extensions, if no rating of “D” or “F” is assigned for any quarter and the average quarterly rating for the entire Project duration is 85 or greater.

If a “D” or “F” rating is assigned by the EMT for any quarterly period, the Administration will impose liquidated damages to the Design-Builder in the amount of \$15,644 per day until a “B” rating or better is achieved.

3.12 DESIGN-BUILDER RESPONSIBILITIES

The Design-Builder shall demarcate with stakes and flagging and maintain for the duration of the Project boundaries of all wetlands, wetland buffers, floodplains, tree protection areas, and the Limits of Disturbance (LOD) as specified. Prior to beginning any earth disturbing activity the Design-Builder shall have all demarcated wetlands, wetland buffers, floodplains, tree protection areas, and LOD inspected and approved by the Administration and MDE. The Design-Builder shall construct all ESC measures in conformance with this Specification. The Design-Builder shall have all control measures inspected and approved by the EMT and MDE Inspector prior to beginning any other earth disturbing activity. The Design-Builder shall ensure that all runoff from disturbed areas is directed to the sediment control measures. The Design-Builder shall not remove any demarcation device or erosion and sediment control measure without the consent of the Administration and MDE Inspector.

3.13 SCHEDULE

At least 14 days prior to initiating any earth disturbance on the Project, the Design-Builder shall submit an ESC Schedule to implement the ESC Plan to the Administration and MDE for approval. The schedule shall indicate the sequence of construction, implementation and maintenance of controls, temporary and permanent stabilization, and the various stages of earth disturbance. After acceptance of the schedule by the Administration, it will be forwarded to MDE for formal approval. The schedule shall, as a minimum, include the following:

- A) Demarcation (and maintain demarcation for the duration of the local earth disturbing activity) of all wetlands, wetland buffers, floodplains, tree protection areas, and the LOD prior to any earth disturbing activity;
- B) Clearing and grubbing of areas necessary for installation of perimeter controls specified in the Contract Documents;
- C) Construction of perimeter controls specified in the Contract Documents;
- D) Remaining clearing and grubbing;
- E) Roadway grading (including off-site work).
- F) If applicable, utility installation and whether storm drains shall be used or blocked after construction;
- G) Conversion of sediment basins to permanent SWM facilities;
- H) Final grading, landscaping, and stabilization; and
- I) Removal of perimeter controls.

No earth disturbing activities shall be started on-site or off-site until the ESC schedules and methods of operation have been accepted by the Administration and MDE. The Design-Builder's Project Superintendent and ESC Manager shall complete the Administration's ESC course successfully prior to initiation of any land disturbing activities on the Project.

3.14 SEVERE WEATHER EVENT

ESCs shall be maintained at all times. When a Severe Weather Event occurs, which for ESC purposes a Severe Weather Event is defined as 3.0 inches or more of rainfall within a 24 hour period, the Design-Builder shall maintain, repair or replace any damaged ESC devices within 48 hours or prior to the next rainfall event, whichever comes first. Qualification as a Severe Weather Event will be based upon rainfall data recorded at the Rockville 1 NE National Weather Service Station as reported by the National Climatic Data Center (NCDC), Asheville, NC. A lump sum payment of \$24,420 will be paid for each Severe Weather Event occurring between the start of grading operations and removal of the ESCs. The purpose of the lump sum payment is to mitigate the Design-Builder's risk with regard to maintenance, repair and/or replacement of any and all ESC devices damaged by the event provided that a minimum rating of "B" is maintained immediately before and within 48 hours following the rainfall event. The Design-Builder shall be responsible for submitting the official weather records documenting the event.

3.15 ESC SPECIFIC DESIGN CRITERIA

Prior to permanent seeding and mulching, slopes outside the roadway hinge point, flatter than and including 2:1 slopes, shall be covered with 2 inches of topsoil. Slopes within the roadway hinge points, flatter than and including 2:1 slopes, shall be covered with 4 inches of topsoil.

Slopes steeper than 2:1 shall be evaluated for slope stability and prepared to promote vegetative growth in accordance with Geotechnical Performance Specification and Planting and Landscape Architectural Performance Specification.

Daily stabilization for land disturbance within any drainage areas adjacent to wetlands and streams shall be accommodated in the design and implementation of the ESC plans.

In order to protect and maintain the high value of natural resources located within the Montgomery County Special Protection Area (SPA), the Design-Builder shall present to the Administration, prior to proceeding with any construction operations, a written erosion and sediment control narrative describing how construction operations in the SPA will be addressed including redundancy of protective measures and other safeguards to afford the highest level of protection from sediment pollution. The Design-Builder shall participate in coordination with Montgomery County regarding design and construction within SPAs. Efforts that exceed MDE requirements in the SPA are expected and shall be documented with photos, written descriptions and other evidence (material receipts, etc.) as part of an as-built record. The as-built record shall be maintained up to date throughout construction and submitted to the Administration on a monthly basis and in final form upon Project completion. At a minimum, the plan shall address measures to limit erosion potential, retain sediment on-site, and proactively manage the execution of grading operations, and maintenance and functionality of controls.

Potential strategies to limit the potential for erosion may include, but are not limited to, the following:

- A) The use of clear water diversions shall be used to the maximum extent feasible to limit the amount of area required to be controlled;
- B) More frequent stabilization than is currently required by MDE regulations to minimize the duration that disturbed soil is exposed;
- C) Staging the construction to limit clearing, grubbing and area of disturbance to what is necessary to carry on a grading operation (EDA) to minimize the area and duration of soil exposure;
- D) Providing artificial or organic erosion resistant ground cover on stockpiles, steep slopes, and other exposed or disturbed areas in sensitive locations, prior to the onset of a forecast rainfall event;
- E) Providing top of fill berms with pipe slope drains to convey discharge down steep slopes,
- F) Benching long cut or fill slopes to limit the risk of rilling on steep slopes and to lessen the slope of longitudinal ditches; and
- G) Other innovative techniques presented by the Design-Builder with prior written concurrence from the Administration and approval from MDE prior to construction.

The Design-Builder shall make every attempt to retain sediment generated by construction operations within the site. This shall minimally entail the use of both primary and supplementary sediment control measures. Some examples of these may include, but are not limited to, the following:

- 1) To address Sheet Flow discharge - A layer of primary sediment control, such as silt fence or Super Silt Fence plus a secondary layer of control such as mulch tubes, compost socks, or mulch berms to minimize the release of fine particles.
- 2) To address Concentrated Flow discharge - Within Use III Watersheds, all areas

within the limit of disturbance (LOD) must be protected by a layer of primary control such as a sediment trap or basin, supplemented by a secondary layer (or layers) of control such as:

- a) An additional trap or basin (space permitting) or additional trap or basin volume;
- b) Stone check dams, compost socks, linings, strip sod, or other erosion inhibitors in influent ditches to sediment traps;
- c) Ensuring effective drawdown and dewatering of sediment traps and basins prior to forecast rain events by pumping to filter bag(s) and mulch berm(s) or other approved devices to ensure that dewatered storage component of sediment trap is available for the future storm event(s);
- d) Efforts to minimize the potential for re-suspension of particulates; and
- e) Other innovative techniques presented by the Design-Builder with concurrence from the Administration and approval from MDE prior to construction.

4.0 SUBMITTALS

4.1 STORMWATER MANAGEMENT AND SURFACE DRAINAGE PLANS

The following items shall be included in the design plan documents:

- A) Pipe profiles for all storm drain systems. Profiles shall be at a scale of 1 in. = 50 ft. horizontal and 1 in. = 5 ft. vertical. The 25-year hydraulic gradient and existing and proposed ground, proposed pipe, existing utilities and existing structures shall be shown on all storm drain profiles;
- B) Details for all non-standard or modified drainage structures.
- C) Stormwater Management Systems including spot elevations, contours, drawings and views as specified in MD-378;
- D) Side, median and outfall ditch elevations, offsets, and configurations and surface treatments;
- E) Underdrain connections, locations (including linear filter clean outs), and outlets;
- F) Cross culvert locations, headwater pool areas, and channel changes required to adjust streams to culverts;
- G) In-stream measures required to maintain long term stream stability; and
- H) Spring box and outlet locations and configurations.

4.2 EROSION AND SEDIMENT CONTROL PLANS

The Design-Builder shall develop ESC Plans that include the following in addition to the highway plan requirements.

- A) At a minimum, plans for both initial and final stages of the construction are required. The plans will require 2 foot contouring and interim contours as needed for both existing (pre-construction) conditions and final grade at the same scale as the roadway plans.

- B) The initial phase plan will detail the implementation of ESC measures necessary to complete the clearing and grubbing and the initial stages of the TCP.
- C) Interim phase(s) of ESC may be required to address changes in drainage characteristics during construction or changes necessitated by multiple phase traffic control plans. Interim phase plans will require 2 foot contouring showing existing or previously constructed conditions and proposed grades to be established by each particular interim phase being addressed.
- D) The final phase will detail the control measures required to move to final grade and accommodate interim traffic control phases. Final phase shall also address conversion of temporary sediment control basins to stormwater management ponds where appropriate.
- E) Larger scale drawings (1 in. = 200 ft.) will be included in the plans depicting off-site drainage areas, sensitive environmental resource areas such as wetlands, woodlands, streams, and locations of major diversions and sediment controls.
- F) This plan will be coordinated with the MDE Non-tidal Wetland and Waterways Division to ensure compliance with ESC measures in areas subject to waterway construction permits. The Design-Builder shall be responsible for all revisions due to MDE review and comment.
- G) All plans shall be sealed and signed by a Maryland Registered Professional Engineer.
- H) Earth Disturbance Area (EDA) Plan as outlined in 3.8.1.C above.

4.3 STORMWATER MANAGEMENT REPORTS AND MANUALS

A SWM Engineering Report and SWM Maintenance and Operation Manual shall be completed for the Project. The SWM Engineering Report shall be prepared in conformance with MDE's Stormwater Management Guidelines for State and Federal Projects, July 2001, and these Specifications. The SWM Maintenance and Operation Report shall conform to these Specifications. Upon completion of Project, the Design-Builder shall submit 2 hard copies and 1-electronic copy in portable document format (.pdf) each of the approved, final Stormwater Management Engineering Report and Stormwater Management Maintenance and Operation Manual to the Administration. During the review and approval process, the SWM Engineering Report can be submitted in phases, as discussed below.

4.3.1 SWM Engineering Report Format

The report and accompanying mapping shall be compiled as follows:

- A) The report shall be written in a clear, well organized and concise manner with all the pages numbered and dated;
- B) The report shall be placed in an 8½ by 11 inch, 3-hole binder that allows for insertion of revisions and removal of deletions and old data;
- C) The Design-Builder shall make revisions to the report as required to keep reports current with design and construction activities. The date of the revision shall be placed on all pages and pages to be added, replaced or removed shall be designated. Revisions shall be 3-hole punched for easy placement in the reports; and
- D) The final, approved report shall be converted to a Portable Document Format (.pdf) file, including all mapping and exhibits. The electronic file shall be delivered to the Administration for their records.

4.3.2 SWM Engineering Report Contents

In addition to MDE requirements, the Stormwater Management Engineering Report shall contain the following:

- A) A thorough discussion explaining the extent of improvements at each outfall and the proposed quantitative and qualitative methods of SWM, including those reasons why others were not selected;
- B) An explanation of hydrologic/hydraulic analysis methodologies used (i.e., TR-20, HEC-RAS programs). Final supporting computations, maps, schematics, cross-sections, details and computer runs shall be included for each outfall location;
- C) Outfall stability analysis including pre- and post-construction photographs taken of each outfall and receiving channel;
- D) Computations for riprap sizing and outlet protection design;
- E) Maps and schematics clearly showing the location of subareas, structures, existing land use, time of concentration paths, soil types and SWM facilities. Maps shall be folded to 8-1/2" X 11" with map title showing and included in pockets within the report;
- F) Computer printout sheets in 8½ inch x 11 inch format. These sheets shall be clearly labeled for cross-reference to the supporting data and points of analysis;
- G) MDE Pond Summary Sheets (included with this package);
- H) ICC Water Quality Summary (included with this package) submitted to the Administration for signature, and maps detailing the types of impervious area treated and the amount of water quality treatment required and provided at each outfall;
- I) NOI Form (Included with this package) filled out and submitted to the Administration; and
- J) SHA BMP Summary Sheet (included in this package) with SHA BMP numbers indicated. The Design-Builder is responsible to obtain BMP numbers for all structural SWM facilities from the Administration.

4.4 SWM MAINTENANCE AND OPERATION MANUAL FORMAT

Because the ICC Stormwater Management Systems may require proprietary or specific maintenance procedures to ensure peak performance and long term effectiveness, the Design-Builder shall produce and submit to the Administration a written document for reference by future stormwater management maintenance forces.

The Manual shall be written in a clear, well organized and concise manner with all the pages numbered and dated.

The report shall be placed in an 8½ by 11 inch, 3-hole binder that allows for insertion of revisions, removal of old data, and addition of maintenance inspection field reports. Final manual sheets to be used for field reference shall be laminated to prevent damage from handling or the elements.

Revisions to report as required. The date of the revision shall be placed on all pages and pages to be added, replaced or removed shall be designated. Revisions shall be 3-hole punched for easy placement in the reports.

The final approved report shall be converted to a Portable Document Format (pdf) file, including all mapping and exhibits. The electronic file shall be delivered to the Administration for their records.

4.4.1 SWM Maintenance and Operation Manual Content

The SWM Maintenance and Operation Manual shall contain the following:

- A) An overview discussion explaining the BMPs included on the Project, as well as the purpose (quality or quantity control) of each;
- B) Design details including GIS points and datums required for adequate maintenance of each type of facility;
- C) Mapping and photos of maintenance vehicle parking and facility access locations;
- D) Removed material testing and disposal requirements, if any;
- E) Manufacturer and supplier information for proprietary devices, if any. Lists of maintenance materials and procedures required for non-proprietary items;
- F) Listing of special certifications or training required to safely perform maintenance activities. The Design-Builder shall provide for the training of up to 4 Administration designated staff required to safely and adequately maintain SWM facilities constructed on the Project;
- G) Maintenance Inspection Form; and
- H) Other information that the Design-Builder feels is necessary to adequately maintain each stormwater management facility.

4.5 (SURFACE) DRAINAGE REPORT

A Final Drainage Report shall be prepared by the Design-Builder and submitted to the Administration for review and acceptance prior to final Project close-out. The Drainage Report shall include all surface drainage design computations performed to demonstrate compliance with the SHA Highway Drainage Manual and these specifications, along with drainage area mapping and schematics necessary to complete the design of the stormwater conveyances for the Project.

4.5.1 Surface Drainage Report Format

- A) All the pages within the report shall be numbered and dated.
- B) The report shall be placed in an 8½ by 11 inch, 3-hole binder that allows for insertion of revisions and removal of old data.
- C) The Design-Builder shall make revisions to the report as required to keep reports current with design and construction activities. The date of the revision shall be placed on all pages and pages to be added, replaced or removed shall be designated. Revisions shall be 3-hole punched for easy placement in the reports.
- D) The final approved report shall be converted to a Portable Document Format (pdf) file, including all maps and exhibits. The electronic file shall be delivered to the Administration for their records.

4.5.2 Surface Drainage Report Contents

The report shall include but not be limited to the following:

- A) All drainage computations performed including clear references to the appropriate charts used;
- B) Culvert Analysis reports, when necessary for Waterway Construction Permit review and approval, shall be included as an attachment to the Drainage Report. The content shall be in conformance with COMAR 26.17.04 and MDE's Waterway Construction Guidelines, MDE comment letter(s) and approval, or subsequent requirements issued by MDE in the review and approval process;

- C) Storm sewer design computations including schematics, inlet drainage area maps, spacing, capacity and spread, and hydraulic gradients and structural design for special drainage structures;
- D) Culvert analysis including 2, 10, 25 and 100 year frequency storms and design storms;
- E) An explanation of hydrologic/hydraulic analysis methodologies used (i.e., TR-20, GIS-Hydro, HEC-RAS programs). Final supporting computations, maps, schematics, cross-sections, details and computer runs shall be included for each culvert location;
- F) Ditch computations and drainage area maps for ditch capacity, freeboard and lining stability;
- G) Evaluation of stable outfalls and outfall protection design; and
- H) Any deviations from the guidelines and SHA acceptance for the same.

PS 310 - ENVIRONMENTAL PERFORMANCE SPECIFICATION

1.0 GENERAL

The Design-Builder shall conduct its design and construction activities in accordance with these specifications such that no action or inaction on the part of the Design-Builder shall result in non-compliance with the requirements contained in the Intercounty Connector Final Environmental Impact Statement (FEIS), Record of Decision (ROD), Section 106 Memorandum of Agreement (MOA), 1989 MOU with M-NCPPC, Clean Water Act Sections 404 and 401 authorizations/permits, floodplain permits, approvals, and all other necessary permits and approvals required by the Project.

1.1 GENERAL ENVIRONMENTAL PHILOSOPHY

The Intercounty Connector Project passes through an area of rich and diverse environmental, community, and cultural resources. Protection of these resources is of paramount importance. The philosophy followed by the Federal Highway Administration, the Maryland Transportation Authority, and the Maryland State Highway Administration (Administration) during the development of the RFP Plans, the FEIS and the ROD was to incorporate environmental stewardship measures and avoid and minimize impacts to the natural, forest areas in Special Protection Areas, community, cultural resources (Section 106 Resources), and Parkland (Section 4f) to the greatest extent feasible and practical. The Design-Builder shall continue this environmentally sensitive approach and philosophy during the preparation of final design plans and through Project implementation. The Administration has implemented innovative approaches to reward the Design-Builder for high quality environmental performance, as stated in various sections of this Performance Specification. These innovative approaches include incentives for reductions to forest impacts, especially to forested areas adjacent to or continuous with Park boundaries, increases to on-site reforestation areas, and reductions to wetland and stream impacts with additional incentives paid for reductions to wetland and stream impacts within the Special Protection Areas.

2.0 STANDARDS AND REFERENCES

The Design-Builder shall design and implement Environmental requirements in accordance with the relevant requirements of the standards listed by priority in Table 1 unless otherwise stipulated in this specification. Standards specifically cited in the body of this specification establish requirements that shall have precedence over all others. Should the requirements in any Standard below conflict with those in another, the Standard listed with the higher priority shall govern. It is the Design-Builder's responsibility to obtain clarification for any unresolved or perceived ambiguity prior to proceeding with design or construction.

2.1 STANDARDS

Appropriate professional standards and regulations shall be utilized for design and construction implementation of all commitments, considerations, permit conditions and approval requirements.

Standards shall include, but are not limited to the following:

TABLE 1
STANDARDS FOR ENVIRONMENTAL

<i>Priority</i>	<i>Author or Agency</i>	<i>Title</i>
1		Section 106 of the National Historical Preservation Act (16 USC § 470f)
2		Section 4(f) of the US Department of Transportation Act (23 USC § 138)
3		Code of Federal Regulations (CFR)
4		Code of Maryland Regulations (COMAR)
5	USACE	Clean Water Act Section 404 Permit Application and Authorization
6	MDE	Clean Water Act Section 401, Water Quality Certification for ICC
7	MDE	Nontidal Wetland and Waterway Construction Permit Application and Authorization for ICC
8		Secretary of the Interior's Standards and Guidelines for Archeology and Historic Preservation (1983 and successors)
9		Standards and Guidelines for Archeological Investigations in Maryland (Shaffer and Cole 1994)
10		Standards and Guidelines for Architectural and Historical Investigations in Maryland (Maryland Historical Trust, 2000)
11		Recommended Approach for Consultation on Recovery of Significant Information from Archeological Sites, ACFIP 1999 (64 FR 27085-27087)
12		Secretary of the Interior's Standards for the Treatment of Historic Properties (36 CFR Part 68)
13	SHA	Standard Specifications for Construction and Materials for items identified as Standard in Attachment A of Part 3-Design Requirements
14	SHA	Book of Standard for Highways, Incidental Structures and Traffic Control Applications for items identified as Standard in Attachment B of Part 3-Design Requirements

2.2 REFERENCES

The discussion of environmental, community, parkland, and cultural resource impacts, mitigation measures, conditions and commitments included in the references listed below shall serve as a guideline/reference for the Design-Builder in developing strategies for avoiding impacts, minimizing impacts and working closely with the public. These technical reports can be obtained from the Administration.

TABLE 2
REFERENCES FOR ENVIRONMENTAL

<i>Author or Agency</i>	<i>Title</i>
FHWA/SHA/MdTA	Intercounty Connector Natural Environmental Technical Report for the ICC
FHWA/SHA/MdTA	Intercounty Connector Air Quality Technical Report
FHWA/SHA/MdTA	Intercounty Connector Environmental Stewardship Technical Memorandum
FHWA/SHA/MdTA	Intercounty Connector Impact Assessment Technical Report
FHWA/SHA/MdTA	Intercounty Connector Noise Quality Technical Report
FHWA/SHA/MdTA	Intercounty Connector Secondary & Cumulative Effects Analysis Technical Memorandum
FHWA/SHA/MdTA	Intercounty Connector Socioeconomic and Land Use

	Technical Report
FHWA/SHA/MdTA	Intercounty Connector Initial Site Assessment (ISA) Technical Report
FHWA/SHA/MdTA	Intercounty Connector Initial Site Assessment (ISA) Technical Report, Addendum I-Preliminary Site Investigation Screening
FHWA/SHA/MdTA	Intercounty Connector Supplemental ISA Technical Report
FHWA/SHA/MdTA	Intercounty Connector Final Environmental Impact Statement
FHWA	Intercounty Connector Record of Decision for the ICC
FHWA/MHT	Intercounty Connector Section 106 MOA
SHA	ISDT Stream Design Process Guidelines
M-NCPPC	Environmental Guidelines and Tree Handbook

2.3 OWNER'S ENVIRONMENTAL ROLES AND RESPONSIBILITIES

The Administration has conducted extensive coordination with various environmental and regulatory agencies and the public through the planning and permitting processes. During that time, commitments and considerations have been made that are recorded in the FEIS, ROD, Section 106 MOA and various permits and approvals. The Administration has compiled these commitments and considerations in a Commitment Tracking Database (CTD), which is included as Appendix C to this Part 3-Design Requirements. The database will be updated upon receipt of permits for the Project. The Administration will manage and update the database periodically.

The Administration will provide an Environmental Management Team (EMT) that will work with the Design-Builder's Environmental Manager and Staff to confirm the Design-Builder's plans and construction methods are in compliance with the CTD. The EMT will:

- A) Review plans as they are developed;
- B) Perform Erosion and Sediment Control Quality Assurance Ratings, as defined in the Drainage Performance Specification;
- C) Review the Design-Builder's environmental compliance implementation;
- D) Notify the Design-Builder's Environmental Manager of deficiencies in the compliance with the commitments, considerations, permits and approvals; and
- E) Coordinating and attending any meetings involving resource or regulatory agencies.

The Administration will provide an Independent Environmental Monitor (IEM), on behalf of the USACE and MDE, as required by permit conditions. The IEM will monitor the design and construction of the Project full-time to assure that all regulatory permit conditions and commitments are met.

2.4 DESIGN-BUILDERS RESPONSIBILITIES

The Design-Builder shall be responsible for compliance with the CTD throughout the design and construction of the Project. The Design-Builder shall demonstrate compliance by producing a CTD Compliance Checklist with memorandum and explanation of issues at each design milestone, which tracks and confirms compliance with each commitment applicable to the design of the Project. During construction, the Design-Builder shall produce a Compliance Report each quarter, which tracks and confirms compliance with each commitment pertaining to the construction of the Project, and also tracks impacts to wetlands and waters of the US. The checklist and memorandum shall be submitted

to the Administration within one week after the end of each quarter.

The Design-Builder shall provide an Environmental Manager (EM) as one of the key staff managers. The EM shall have a minimum of 10 years experience with demonstrated expertise in environmental permitting, environmental design, and construction management and compliance on large, complex transportation projects in environmentally sensitive areas.

The EM and his/her team shall be responsible for all environmental design and construction issues required for the Project. The EM shall report directly to the Design-Builder's Project Manager and will be the primary liaison to the Administration for environmental issues. The EM shall be committed full-time, on-site with environmental management as this individual's sole responsibility. The EM shall have the authority to stop and/or direct construction activities should the need arise.

The Design-Builder shall provide an Environmental Compliance and Awareness Training Program for all personnel, including those of subcontractors, whose duties require that they enter within the boundaries of the ROW and/or limits of disturbance established for the Project. The purpose of this training is to ensure that all personnel are educated on the environmental compliance requirements and environmental sensitivities of the Project. This training program shall cover the elements in PS 303-Drainage and this performance specification, including but not limited to the following:

- A) Implementing and maintaining erosion and sediment control;
- B) Maintaining approved limits of disturbance;
- C) Tree protection;
- D) Wetland and waterway protection;
- E) Wildlife protection;
- F) Time of year stream work restrictions;
- G) Pumping and dewatering operations; and
- H) Recognizing the consequences for departure from approved operating procedures.

The outline of the training program elements and procedures shall be developed into the Environmental Compliance and Awareness Training Program and shall be submitted to the Administration for review and written comment within 30 days of Notice to Proceed. The plan shall be finalized by the Design-Builder prior to initiating any Work within the ROW and/or limits of disturbance. No personnel shall be allowed to enter the Project ROW until they have completed the environmental training program. Continuing training shall be provided in the form of monthly tool-box sessions, similar to traditional monthly safety training programs. Documentation of attendance for orientation and monthly environmental training for all employees shall be provided to the Administration on a monthly basis.

2.5 PERMITS AND APPROVALS

The Administration will be relying on the Design-Builder to achieve and maintain commitments and permits through a strong Environmental Compliance Plan and partnering with the Administration. The Design-Builder is encouraged to consider environmental stewardship measures that exceed those in the CTD, while considering reasonable cost and practicality.

- A) The totals that are currently authorized to be impacted for the Project are listed below. Any increase to the impacts at the specific stream and wetland locations will require a permit modification (refer to Section 3.1 Permit Modifications and Approvals of this

Performance Specification for the requirements). Decreases in wetland and/or stream impacts may not require a permit modification. A portion of the Project is located in the Upper Rock Creek Special Protection Area (refer to the Drainage Performance Specification for special requirements). The totals that are currently authorized are:

- 1) 10,609 linear feet of permanent and 274 linear feet of temporary impacts to perennial/intermittent nontidal streams;
 - 2) 5.82 acres of permanent impact to nontidal wetlands;
 - 3) 2,138 linear feet of permanent and 25 linear feet of temporary impacts to nontidal ephemeral streams;
 - 4) 0.28 acre of permanent impact to nontidal open water;
 - 5) 16.50 acres of permanent impact to 100 year floodplain;
 - 6) 206 acres of forest impacts;
 - 7) 20.2 acres of direct habitat impact and 52.1 acres of converted habitat to Forest Interior Dwelling Species (FIDS); and
 - 8) 1.6 acres of impact to the Redland Spring Ecologically Sensitive Area.
- B) The Administration will provide the following permits and approvals based on the RFP Plans:
- 1) U.S. Army Corps of Engineers - Section 404 Clean Water Act Permit;
 - 2) Maryland Department of the Environment- Section 401 Clean Water Act - Water Quality Certification;
 - 3) Maryland Department of the Environment- Nontidal Wetland and Waterways Permit;
 - 4) Maryland Department of the Environment - Coastal Zone Management

- Program Federal Consistency Determination;
- 5) Maryland Department of Natural Resources- Scenic and Wild Rivers Approval;
 - 6) Maryland Department of Natural Resources- Forest Impacts and potential on-site reforestation areas approval; and
 - 7) State Board of Public Works- Priority Funding Areas law compliance
- C) The Design-Builder shall obtain the following permits and/or approvals:
- 1) Maryland Department of the Environment General Mineral Mining Permits (for batch plants);
 - 2) Maryland Department of the Environment Water Appropriations Permits (for withdrawals from surface and groundwater);
 - 3) Maryland Department of the Environment Erosion and Sediment Control Approval;
 - 4) Maryland Department of the Environment Stormwater Management Approval;
 - 5) Maryland Department of the Environment Air Quality/Emissions permits during construction;
 - 6) National Pollutant Discharge Elimination System (NPDES) Notices of Intent (NOI);
 - 7) Administration approval for noise compliance during night and holiday construction;
 - 8) Maryland Department of Natural Resources Roadside Tree Permit
 - 9) M-NCPPC Technical Review and Park Permit for construction on M-NCPPC property;
 - 10) All other approvals, permits and licenses, pay all charges, fees and taxes and give notices necessary or appropriate for the implementation of the Project beyond those obtained by the Administration. This includes but is not limited to approvals for on or off-site staging, stockpiling areas, disposal sites and borrows pits; and
 - 11) Maryland Department of Natural Resources fish collection permit for capturing and relocating fish with sampling equipment.
- D) The Design-Builder shall conduct a pre-work meeting with the Administration, USACE, and MDE to discuss permit conditions, compliance measures, design review and coordination, and scheduling.

3.0 PERFORMANCE REQUIREMENTS

3.1 PERMIT MODIFICATIONS AND APPROVALS

The Design-Builder shall obtain approvals from the Administration for any changes in design and/or construction activities that affect any permit conditions and would require a modification approval from the regulatory agencies.

All conditions in the permits shall be adhered to unless modifications are accepted and approved by

the Administration and the regulatory agencies.

Delays due to permit modification approval for permits listed in Section 2.5B, requested by the Design-Builder, will not result in additional costs to the Administration nor will the Contract be extended.

The Design-Builder shall not alter the design in such a manner that increases or creates new impacts to forest, cultural resources, parkland, wetland, wetland buffer, waterway, or floodplain compared to those impacts which were authorized by the permits, illustrated in the RFP Plans and defined in the Joint Permit Application tables. If the Design-Builder determines that changes to impacts are to be considered through design and/or construction, the Design-Builder shall be responsible for providing the Administration with all necessary information required to request and obtain the permits, approvals or modifications from the regulatory agencies. The Administration will be responsible for requesting regulatory agency approval for modifications to permits listed in Section 2.5B of this Performance Specification. The Design-Builder shall be responsible for obtaining modifications to permits listed in Section 2.5C of this Performance Specification. Request for modification to the permits listed in section 2.5B shall be accompanied by documentation provided by the Design-Builder to demonstrate that there is no practical alternative. Additional mitigation required with approval of modifications shall be the responsibility of the Design-Builder.

3.2 ENVIRONMENTAL SUMMARIES

Modifications and/or design changes proposed by the Design-Builder, which occur inside or outside of the planning study area that were not evaluated in the FEIS, such as staging areas, borrow pits or alignment shifts, etc., shall be evaluated by the Design-Builder for NEPA clearance, including evaluations of the natural, social and cultural environments.

The Design-Builder shall provide the above evaluations in a narrative to the Administration. The Administration will coordinate approvals of the environmental summaries with FHWA.

3.3 NATURAL RESOURCES

3.3.1 Groundwater

For details of groundwater protection during construction and stormwater management, see the Drainage Performance Specification.

The Design-Builder shall be responsible for design measures that maintain and discharge natural groundwater flows and seeps associated with waters of the US and wetlands. Special care shall be given to maintaining the existing seep at approximately Station 174+00. The design measures will be reviewed by the Administration prior to implementation.

The Design-Builder shall provide protective measures at cut slopes or ditching adjacent to non impacted or temporarily impacted wetlands to ensure that the source of hydrology to that wetland is preserved. If it is determined that the wetland has been altered hydrologically, it will be considered an additional impact, for which the Design-Builder shall be responsible for providing permit modification documentation as well as mitigation at the designated ratios, per COMAR, for the impacts.

Within one year of the completion of the construction, an inspection will be conducted by the Administration and the regulatory agencies to determine whether any remnant wetlands have lost their hydrology. If it is determined that remnant wetlands are no longer functioning as a jurisdictional wetland, the Design-Builder shall be responsible for costs associated with the additional mitigation

required. Mitigation ratios for the lost wetlands shall be in accordance with COMAR

3.3.2 Surface Water

For details on Erosion and Sediment Control and Stormwater Management, see the Drainage Performance Specification.

The Design-Builder shall not discharge or allow the release of any sediment laden construction water unless properly treated. The Design-Builder shall obtain Administration approval of all dewatering operations prior to pumping and discharge. Water to be pumped and discharged shall be in conformance with the COMAR Standards.

To minimize potential for untreated discharge, the Design-Builder shall designate, design and construct, utilize, maintain and upon conclusion of operations, properly close concrete wash-out pits for all concrete production, transport and placement operations. The location of concrete wash-out pits shall be approved by the Administration prior to use. The pits shall be managed such that no concrete waste or wash water is discharged into waters of the US. This may include the implementation of drying beds with proper sediment controls and treatment of excess wash water on-site or proper off-site disposal.

The Design-Builder shall be responsible for furnishing automated water quality data loggers as well as the installation, maintenance, calibration, data downloading and handling, reporting, and all incidentals. The water quality data loggers shall record baseline data, during-construction data and post-construction data for pH, Turbidity, Temperature, conductivity, and Dissolved Oxygen levels every 15 minutes from one month after Notice to Proceed of the Project until one year after all contributory watersheds are deemed fully stabilized by the Administration. Upon Administration approval, the Design-Builder shall remove data loggers. The Design-Builder shall monitor water quality at the upstream and downstream Right-of-Way limit of all perennial/intermittent streams (Stations 5051+00, 209+00 Ramp B I-370, 114+00, 123+50, 129+00, 151+00, 173+00, 174+50, 110+50 Needham Road, 207+00, 276+50, 239+00, 300+00, 312+00, 313+50 NBSVP, 328+00 NBSVP, and 415+00) within the Project. Data shall be downloaded and submitted unaltered to the Administration with a narrative report each quarter. The Design-Builder shall review the data and make adjustments daily.

If construction discharges exceed water quality standards identified in COMAR, the Design-Builder shall immediately notify the Administration and resolve any Project related deficiencies within 24 hours.

The Administration will request spot-check downloads at any time to verify compliance.

3.3.3 Aquatic Biota

The Design-Builder shall:

- A) Conduct all work so as to avoid/minimize fish mortality from both construction related water quality impairment and in-stream activities. The Design-Builder shall notify the Administration 48 hours prior to the commencement of any stream dewatering or other in-stream activities.
- B) Perform fish relocation, which shall include at least two passes with a net and/or an electrofishing unit of the dewatered work area. Fish screening over the pump intake shall be used to prevent uptake of aquatic biota during dewatering. Fish relocated by electrofishing shall be collected in buckets and allowed to regain consciousness before being returned to the stream. All fish shall be released downstream of the work area.

The Design-Builder shall provide to the Administration documentation in the form of a memorandum within one week of the work detailing the fish relocation activities.

- C) Comply with all water quality standards stated in the COMAR for the protection of aquatic biota.
- D) Conduct all in-stream work for culverts and bridges in compliance with the Maryland mandated stream closure periods for the designated use class of the stream stated in the MDE Water Quality Certification. Temporary crossings, permanent culverts and any riprap placed shall be constructed so as not to obstruct the movement of aquatic species, unless the purpose of the activity is to temporarily impound water.

3.3.4 Wetlands and Waters of the US

Direct impacts to wetlands and waterways are anticipated to occur under the Project. The Tables in the Joint Permit Application present the total impacts permitted for the ICC Project. All wetlands and waterways were identified, delineated and surveyed within the Project. A summary of the delineation information can be obtained from the Final Environmental Impact Statement, the RFP Plans, and the ICC Jurisdictional Determination. Surveyed boundaries of waterways and wetlands are depicted on the RFP Plans. Prior to performing any work on the Project, the Design-Builder shall be responsible for installing temporary orange safety fence and prohibitive signage in English and Spanish adjacent to non-impacted areas of wetlands and their buffers, identified in the Section 404 Permit, along the limits of disturbance and/or right of way. The orange safety fence shall be installed at a maximum of 25 feet from the proposed toe of cut/fill adjacent to wetlands as depicted on the RFP Plans. The wetland fencing locations should be staked prior to the pre-construction meeting. All personnel of the Design-Builder or subcontractors shall be alerted to these designated protection areas.

3.3.4.1 Occupying Wetlands/Waterways

The Design-Builder is hereby alerted to the importance of protecting waterways and wetland areas. The Administration, in conjunction with the various environmental regulatory agencies, have developed RFP Plans, which minimized or eliminated disturbance and damage to existing waterways and wetland areas. To the extent practical, the Design-Builder shall further avoid and minimize impacts to wetlands and streams in the development of final design plans and during construction. In order to accomplish this, the following must be adhered to:

- A) The Design-Builder shall not impact any wetland or waterway, whether it is permanent or temporary unless permitted and approved as an authorized action by the appropriate regulatory agency.
- B) The Administration shall be immediately notified of inadvertent impacts to wetlands or waterways for which activities are not permitted. Areas shall be immediately restored to the full satisfaction of the Administration and the environmental regulatory agencies. The cost of restoration and mitigation of the impacted areas shall be the responsibility of the Design-Builder.
- C) The Design-Builder shall prepare and submit a revised permit package at the conclusion of construction for the Administration's use in coordinating with the environmental regulatory agencies. The Design-Builder shall survey as-built conditions of the entire Project and submit the information on standard 11x17 half-scale plans in the same format as the RFP Plans. In addition the Design-Builder shall revise the tables in the Joint Permit Application to reflect the final wetland and waterway impacts.

3.3.4.2 Best Management Practices for Work in Nontidal Wetlands, Wetland Buffers, Waterways, and 100-Year Floodplains

- A) The Design-Builder shall not stockpile or store excess fill, construction material, equipment nor debris in un-permitted nontidal wetlands, nontidal wetland buffers, waterways, or the 100-year floodplain.
- B) The Design-Builder shall not place materials in a location and manner, which adversely impacts surface or subsurface water flow into or out of nontidal wetlands, nontidal wetland buffers, waterways, or the 100-year floodplain.
- C) The Design-Builder shall not use excavated material as backfill if it contains waste metal products, unsightly debris, toxic material, or any other deleterious substance. If additional backfill is required, the Design-Builder shall use clean materials that are free of waste metal products, debris, toxic material, asphalt, or any other deleterious substance.
- D) The Design-Builder shall not operate heavy equipment in a manner that will damage un-permitted nontidal wetlands, nontidal wetland buffers, waterways, or the 100-year floodplain.
- E) The Design-Builder shall repair and maintain any serviceable structure or fill so there is no permanent loss of nontidal wetlands, nontidal wetland buffers, or waterways, or permanent modification of the 100-year floodplain in excess of that lost under the originally permitted structure or fill.
- F) The Design-Builder shall restore any nontidal wetlands, wetland buffers, waterways, or 100-year floodplain temporarily impacted by any construction to the full satisfaction of the Administration, regulatory agencies, and in accordance with the requirements of the USACE permit.
- G) The Design-Builder shall use the following species for all stabilization in the nontidal wetland and nontidal wetland buffer: annual ryegrass (*lolium multiflorum*), millet (*setaria italica*), barley (*hordeum sp.*), oats (*uniola sp.*), and/or rye (*secale cereale*). Other non-persistent vegetation may be acceptable, but must be approved by the Administration and MDE Nontidal Wetlands and Waterways Division. Kentucky 31 fescue shall not be utilized in wetland or buffer areas. Areas shall be seeded and mulched to control erosion after construction activities have been completed. Refer to the Drainage and Planting and Landscape Architectural Performance Specifications for details.
- H) The Design-Builder shall make post construction grades and elevations the same as the original grades and elevations in temporarily impacted areas after construction has been completed.
- I) The Design-Builder shall protect aquatic species. In-stream work is prohibited as determined by the classification of the stream and the time of year restrictions specified in the MDE Water Quality Certification.
- J) The Design-Builder shall control stormwater runoff from impervious surfaces to prevent the washing of debris into the waterway.
- K) The Design-Builder shall use disposal areas for excess excavation that do not impact wetlands or waterways. The Design-Builder shall track the disposal of all excess excavation to ensure that there is no unauthorized discharge of fill in regulated wetlands or waterways and shall notify the Administration of the intended disposal

site location for excess excavation or rubble waste removed from the Project.

3.3.4.3 Conversion from Forested and Scrub-Shrub Wetlands to Emergent Wetlands

Several palustrine forested and/or scrub-shrub wetland areas were identified under proposed bridges. Wetlands under bridges with greater than 30 foot clearance are classified as temporary impacts. Wetlands under bridges with less than 30 foot clearance are considered wetland conversion from palustrine forested or scrub-shrub wetlands to emergent wetlands. In temporary and converted wetlands areas, vegetation may be cleared but shall not be grubbed except for areas excavated for bridge piers. The topography and hydrology connections shall remain the same as or be restored to pre-construction conditions.

The specific location of conversion to emergent wetlands for this Project is between RFP Plans station 325 and 330, west of MD 97, wetland 1Z. The conversion impact is 436 square feet (0.01 acre). The area shall be revegetated with a native wetland emergent seed mix that has been submitted to, and approved by the Administration prior to its use. Additional emergent wetland remediation efforts shall be implemented by the Design-Builder, if after three years the area is not a functioning wetland. The Design-Builder shall be responsible to mitigate at a 1:1 ratio for the lost resource if remediation does not prove successful one year after the remediation efforts were implemented at no additional cost to the Administration.

3.3.4.4 Temporary Impacts to Streams

Temporary stream impacts are anticipated by the construction of the Project. Temporary impacts are defined as waterways that are temporarily altered during construction, but are restored to pre-construction conditions after construction is completed. Additional stream stabilization measures may be required to ensure stability of the restored section. Impacts shall be avoided and/or minimized to the greatest extent possible. No grubbing of vegetation that grows beneath the proposed bridges over Rock Creek and North Branch Rock Creek will be allowed, except where needed to construct foundations or to place slope protection. The Design-Builder shall minimize the impacts to wetland areas beneath structures that are designated for slope protection/riprap to the greatest extent possible.

Restoration of temporarily impacted waterways to pre-construction elevations shall be performed by the Design-Builder. There are NO temporary wetland impacts identified or permitted in the Project. However, if pre-construction topography and hydrology connections are restored, the impact may be considered temporary rather than permanent.

The specific location of the anticipated temporary stream impacts are provided in the tables in the Joint Permit Application. Construction details of any temporary stream crossings, temporary stream diversions, temporary stream relocations, and utility installations across waterways shall be prepared for Administration review and for MDE authorization prior to proceeding with construction. Earthen materials will not be permitted in the construction of temporary stream diversions; stream crossings; or cofferdams, due to the potential for washout during storm events.

Only one temporary stream crossing shall be constructed at each bridge or culvert location. At Rock Creek (station 240), North Branch Rock Creek (station 319) and the tributary to North Branch Rock Creek (station 328) temporary stream crossings shall be accomplished using bridges that completely span the stream; no other type of temporary crossing shall be considered.

3.3.4.5 Temporary Impact-Stream, Wetland and Floodplain Restoration Efforts

The restoration plan for the temporary impacts shall include the following elements:

- A) Removal of all construction and temporary fill material;
- B) De-consolidation and/or scarification of compacted soils;
- C) Replacement of topsoil and/or organic matter lost to erosion and sediment control measures;
- D) Re-establishment of grades to preconstruction conditions;
- E) Removal of temporary stream crossings;
- F) Restoration of stream banks with woody vegetation as specified in Planting and Landscape Architectural Performance Specification and Drainage Performance Specification;
- G) Avoid disturbance to riparian vegetation, particularly within 30 feet of stream banks; and
- H) Replant any area within 30 feet of a stream bank that was disturbed temporarily, and that was vegetated pre-construction, with native vegetation similar to pre-construction species composition, with the exception of underground utility corridors. Refer to Planting and Landscape Architectural Performance Specification for details.

Monitoring by the Administration to ensure successful restoration of temporary impacts will continue for one year following the restoration effort. Additional remediation efforts shall be implemented by the Design-Builder if it is determined necessary, after three years. The Design-Builder shall be responsible to mitigate for the lost resource if remediation does not prove successful one year after the remediation efforts were implemented.

3.3.4.6 Stream Relocations

The Design-Builder shall relocate the tributary to North Branch Rock Creek at centerline Station 328+05 beneath the structure. Retaining walls or wing walls shall be used to ensure that the structure and fill are no closer than 20 feet to any streambank and that the impact to wetland 1Z is minimized in accordance with the RFP Plans. If riprap is required to be placed on the floodplain floor, it shall be buried so as not to impede wildlife passage.

Other locations for anticipated stream relocations are at: Station 174 (Mill Creek), Station 370 (1DD), MD 97 Interchange (4A) and Station 110 (Overhill Road (IIA)). During design, the Design-Builder shall evaluate whether it is possible to avoid stream channels (or to relocate, if not possible to avoid) throughout the Project, especially at I-370 Metro Access Road (Ramp B) Station 200-216.

All stream relocations shall be designed to the geomorphic characteristics of stable local streams to avoid downstream scour, channel degradation, and shall not create fish blockages. Where the RFP Plans show a right-of-way bump-out for a stormwater management pond or erosion and sediment control basin in the vicinity of a stream, the pond or basin shall be constructed in a manner that does not impound the stream. For any stormwater management pond constructed in the vicinity of a stream, the pond shall be located a sufficient distance from the stream to maintain a 15 foot wide cleared area beyond the toe of any berms surrounding the pond, plus an additional 30 foot wide, or larger, vegetated buffer along the stream. All stream relocation designs shall be approved by the Administration and MDE prior to implementation.

3.3.4.7 Vernal Pools

The Project will directly impact 11 vernal pools, located in the North Branch Rock Creek watershed and one vernal pool in the Upper Rock Creek watershed, approximately 764 square feet. Vernal pools

shall be constructed to replace vernal pool habitat being impacted by the Project. The Administration will coordinate these locations with the M-NCPPC. If the location of the vernal pool(s) is identified in the Project area, the Administration will provide the location(s) of the proposed vernal pools to the Design-Builder within the LOD/Right of Way or on Park-land.

3.3.4.8 Avoidance and Minimization

The Administration proposed avoidance and minimization techniques during the planning and preliminary engineering phase consisted of alignment shifts, replacement of culverts with bridges where practicable, avoiding placement of piers in stream channels, avoiding skewed stream crossings where possible, increased headwall heights for culverts, and reductions in overall roadway section width at stream crossings where safety considerations allow.

The Design-Builder shall focus its efforts to continue to minimize impacts to wetlands, waterways, floodplains, parks and forest in all areas of the Project, especially sensitive areas. Engineering designs shall continue to emphasize avoidance and minimization of impacts as the feasibility and effectiveness of using measures such as retaining walls, steeper fill slopes, increased headwall heights, reduced roadway sections and any other feasible minimization efforts are evaluated.

Side slopes shall be 2:1 or steeper wherever the fill material is adjacent to wetlands or waterways. Refer to the Geotechnical Performance Specification. Bridges are required as shown in the RFP Plans at the major stream crossings. No in-stream bridge piers shall be constructed in any major stream crossing.

3.3.4.9 Wetland and/or Waterway Impact Reduction Incentive

Upon Final Acceptance of the constructed Project, including completion of as-built plans and approval of permit modification by the agencies, the Design-Builder will be provided additional compensation for any wetland impact net reduction in minimum increments of 0.25 acre and will be provided additional compensation for any perennial/intermittent stream impact net reduction in minimum increments of 100 linear feet. Perennial/intermittent stream locations for the Project are identified in Section 3.3.2-Surface Water of this performance specification. This incentive applies to relocation of stream channels in place as long as the function and value of the stream remains unchanged. The additional compensation only pertains to reduced impacts within the limit of disturbance below the permitted thresholds, minus any impact increases that were approved through modifications. This determination will be made by comparing the verified impacts submitted in the as-built plans against the impacts permitted by the agencies in the initial Permits. This incentive will be paid at \$100,000/acre and \$150/LF net saved outside of the Special Protection Area boundary and \$150,000/acre and \$225/LF net saved inside the Special Protection Area boundary.

3.3.4.10 Wetland and/or Waterway Impact Increase Disincentive

Onsite and offsite wetland or stream mitigation will be constructed under separate contracts and are not included in this Project. However, the Design-Builder shall be responsible for the mitigation for any additional wetland or stream impacts proposed within the Design-Builder's Work beyond those originally permitted for the Project. This responsibility may include a site search, agency reviews and approvals, design, obtaining right-of-way and construction. In addition, the Design-Builder shall be responsible for any regulatory imposed wetland restoration/restitution for permit violations, and that such violations will involve a doubling of the normal replacement ratios. The Design-Builder may take advantage of any excess mitigation acreage that is available at the Administration's wetland mitigation sites by appropriately compensating the Administration for the acreage. No mitigation will be required for additional reaches of stream that are determined to require grade control or other bio-engineered stabilization measures to control downstream velocity or tractive force, or to prevent head-

cutting, since these measures are generally considered beneficial to the stream. Increase in wetland and stream impacts beyond the permitted threshold is strongly discouraged and will not be approved by the Administration, unless the Design-Builder can demonstrate that no practicable alternative exists.

3.3.4.11 Permit Modifications

Changes to the RFP Plans may result in the need for a permit modification, in which case the Design-Builder shall be responsible for supplying to the Administration all information needed to obtain approval and authorization from the regulatory agencies for permits that are listed in Section 2.5 (B) as the responsibility of the Administration. The Design-Builder shall be responsible for addressing any comments or issues the regulatory agencies and/or the Administration may have, including those pertaining to avoidance and minimization measures. The Design-Builder shall also be responsible for any cost associated with providing the additional mitigation which may be required by the permit agencies. If available and compensation agreed, the Administration may allow the Design-Builder to use excess acreage at the approved mitigation sites. It is not the responsibility of, nor guaranteed by, the Administration that approval or authorization of the proposed permit modification will be granted by the regulatory agencies. All time delays and costs that result from obtaining a modification approval shall be borne by the Design-Builder. In accordance with the Memorandum of Agreement signed by the permitting agencies, the permit agencies have agreed to respond to all requests for approval within five (5) calendar days. However, it should be noted that a response by a permit agency may involve a request for additional information.

The Design-Builder shall be solely responsible for the permits listed in Section 2.5(C) and modifications.

3.3.5 Reforestation

Reforestation work shall include the performance of all required and applicable Maryland Roadside Tree Law, Reforestation Law and Maryland Forest Conservation Act work associated with the Project.

Approximately 206 acres of direct impacts to forest vegetation have been approved by the Maryland Department of Natural Resources (DNR).

3.3.5.1 Forest Avoidance and Minimization

Before reforestation is approved by the DNR, every reasonable effort shall be made by the Design-Builder to minimize the cutting or clearing of trees. Only the minimum number of trees may be cut, and sound design practices shall be utilized.

Prior to performing any Work, the Design-Builder shall be responsible for performing all tree preservation measures in accordance with Section 120-Tree Preservation of the Standard Specifications for Construction and Materials.

Specimen trees (trees greater than 30" diameter at breast height measured 4.5' above the ground) were identified and evaluated during the FEIS. The Design-Builder shall avoid as many specimen trees as possible without affecting resources with equal or greater regulatory protection. As the design advances, it may be found that specimen trees are located near the outer edge of the required LOD/ROW or just outside the LOD/ROW. If this condition exists, the Design-Builder shall coordinate with the Administration to mark and provide a buffer for any such tree to avoid its removal during clearing and grubbing activities. An adequate buffer is defined as the critical root zone (drip line).

The Design-Builder shall also be responsible for additional mitigation and cost required as a result of

additional forest impacts. If available and compensation agreed, the Administration may allow the Design-Builder to use excess mitigation at approved mitigation sites.

A plan and memorandum shall be prepared that shows the tree and forest locations and impacts and describes the alternative measures that the Design-Builder proposes to use to avoid or reduce impacts to these trees and forest, including alignment or typical section modifications or protective measures. The Administration will review and provide written comments to plans and memorandum in conjunction with the grading plans.

3.3.5.2 Existing Reforestation Areas

There are two recently constructed reforestation areas within the I-370/Shady Grove Road Interchange (southwest quadrant). The Design-Builder shall implement measures to protect these new planting areas. If the Design-Builder impacts these areas, the Design-Builder shall replant two trees for each tree impacted in the same location where the impact occurred.

3.3.5.3 Forest Impact Reduction Incentive

Upon Final Acceptance of Work, completion of as-built plans and approval of modifications by the DNR, the Design-Builder will be provided additional compensation for the net reduction of an area of upland forest impacts with a minimum width of 25 feet inside the the LOD, where the LOD is immediately adjacent to, or contiguous with park boundaries. This incentive will be paid at a rate of \$100,000 per acre for forest area within SPA and at a rate of \$75,000 per acre outside SPA and in increments of 0.25 acre. The additional compensation only pertains to a net reduction of impacts within the limits of disturbance and for a swath of forest a minimum of 25 feet wide. This determination will be made by comparing the impacts determined in the as-built plans against the impacts impacts shown in the RFP Plans. Special care shall be provided to minimize loss of high priority forest at the following locations:

ICC STATION	NATURAL RESOURCE
150-155 (N&S) Mill Creek	Forested stream valley with amphibian populations and wetlands
160-164 (S) Mill Creek	Mature forest on steep slopes within stream valley buffer with amphibian crossing
172-177 (S) Mill Creek	Mature forest on steep slopes within stream valley buffer with amphibian crossing
240-243 (N) Rock Creek	Mature forest within stream valley buffer in Biodiversity Area
321-326 (N) east of North Branch	Mature forest within stream valley buffer in Biodiversity Area
320-324 (S) east of North Branch	Mature forest within stream valley buffer in Biodiversity Area
323-326 (S) west o North Branch	Edge of interior forest buffer, Best Natural Area and Biodiversity Area
333-340 (S) east of North Branch	Mature forest within stream valley buffer

3.3.5.4 Forest Mitigation

Land disturbed by construction activities shall be revegetated as soon as practical after construction is completed in accordance with the Drainage and Planting and Landscape Architectural Performance Specifications. On-site reforestation shall be the responsibility of the Design-Builder. Approximately 74.5 acres of reforestation shall be accomplished on-site for the Project.

Mitigation shall be the responsibility of the Design-Builder for additional impacts proposed beyond those originally approved by DNR for the Project, and may include a site search, agency reviews and approvals, design, and obtaining right of way and construction. If available and compensation agreed, the Administration may allow the Design-Builder to use excess mitigation at the approved mitigation sites.

The Administration will pay an incentive bonus of \$5,000 per 0.50 acre for additional on-site upland reforestation, which meets DNR requirements that is accomplished beyond the approximately 74.5 acres of on-site reforestation specified.

3.3.5.5 Forest Permit Modification

The Administration has approved the upland forest impacts shown in the RFP Plans (approximately 206 acres). Changes to the RFP Plans may result in modifications to forest impacts, which are subject to Administration approval.



The Design-Builder shall prepare and document the request for modifications for submission by the Administration to the DNR for approval of impacts greater than those shown in the RFP Plans.

The Design-Builder shall request a field review with the Administration and provide the Administration with justification if additional trees are requested to be removed. The Design-Builder shall comply with terms of the modified approval(s) from DNR at no additional cost to the Administration.

3.3.6 Terrestrial Wildlife (TW)

3.3.6.1 TW Direct Impacts

Direct impacts to Forest Interior Dwelling Bird Species (FIDS) were determined by measuring the impact to forest interior habitat. Under the Project, 20.2 acres of forest determined to be FIDS habitat is anticipated to be directly impacted and another 52.1 acres of forest interior to be converted to edge habitat. FIDS impacts will occur in two areas, approximately between Station 238+00 and Station 244+00, and Station 312+50 and Station 329+00 in the RFP Plans.

Direct impacts to seasonal pool amphibians, including wood frogs and spring peepers are anticipated to occur through the disturbance of spring seep breeding habitat of these two species on the east side of the Station 174+00 stream crossing.

3.3.6.2 TW Time of Year Restrictions

All clearing of interior forest habitat should be avoided, if possible, from April 1 to August 31 of any year, which is the breeding season for most FIDS.

The Design-Builder should avoid disturbance to the seasonal pool habitat for pool breeding amphibians between April 1 and June 30 of any year at the following locations: 170+00 to 175+00, 205+00 to 212+00, 275+00 to 280+00, and 315+00 to 330+00. The Design-Builder should monitor the seasonal pools weekly beginning in early March to evaluate the presence of seasonal pool breeding amphibians. Monitoring should continue through April 30 or until frog or salamander egg masses are discovered. If egg masses are discovered, the Design-Builder shall coordinate with the Administration to revisit the pools in mid June and determine whether larvae have transformed and vacated the pools. If no seasonal pool amphibian egg masses are discovered by April 30, it will be assumed that breeding of these species will not occur, and construction may continue upon Administration concurrence and assuming all other permits, regulations, and time of year restrictions for other resources are met. Impact to vernal pools should be minimized by reducing impacts to adjacent forest and by providing fencing to prevent amphibians and reptiles from entering the highway (See Planting and Landscape Architectural Performance Specification).

3.3.6.3 TW Avoidance and Minimization

The Design-Builder shall minimize impacts to interior forest and FIDS habitat in Upper Rock Creek and North Branch Rock Creek.

The Design-Builder shall maintain connectivity between wildlife communities to the extent feasible and provide structures with adequate underpass space to allow safe passage of large wildlife under the roadway. Minimum size for deer culverts is a 12' x 12' box, with a one-foot minimum natural substrate covered bottom. Minimum clear opening, if located in a floodplain, shall be set at an elevation that will result in no more than two foot thickness of natural sediment or no less than 10' of vertical clearance. The design shall take into account any filling that may occur due to sediment deposition on the floodplain. There shall be no exposed riprap in either the bottom of the culvert or on the

approaches to the culvert that would make the culvert inaccessible by deer. If other than a rectangular-shaped culvert is used, the cross section of the alternative-shaped culvert shall be large enough that a 12-foot by 12-foot box could fit inside it. Refer to the Drainage Performance Specification for locations of deer culverts.

Small mammal culverts shall be specially designed to accommodate small mammal passage. These culverts could include the use of a two-foot wide “shelf” alongside the waterway, which would not be submerged during normal base flow conditions, or the addition of a dry culvert cell with a minimum diameter of 72 inches alongside the culvert that carries the primary stream flow. Refer to the Drainage Performance Specification for locations of small mammal culverts.

The Design-Builder shall submit wildlife crossing details to the Administration for review and written comment.

Culverts shall provide natural bottom substrates and a smooth bed transition from upstream to downstream allowing for reptile and amphibian crossing as well as fish movement. The Design-Builder shall provide protection for wildlife by installing wildlife and small animal exclusion fencing in appropriate areas along the highway. Refer to Planting and Landscape Architectural and Structures Performance Specifications for details.

If riprap is determined necessary on the floodplain floor under any bridges, the riprap shall be buried with material that is approved by the Administration and easily traversable by wildlife. In addition, the use of slope protection under bridges shall be minimized to retain as much of the natural terrain as possible for wildlife movement and to minimize the disturbance of earthwork in the vicinity of streams. If riprap is needed for energy dissipation at either end of a stream culvert or to protect a buried utility, riprap and stream substrate material shall be placed together to establish a stream invert elevation that will not impede fish passage during low flows.

3.3.7 Rare, Threatened and Endangered Species (RTE)

3.3.7.1 RTE Direct Impacts

No federally listed rare, threatened, or endangered (RTE) species are anticipated to be directly impacted by construction of the Project. One state listed species, the trailing stitchwort (endangered) will be impacted under the Project within the North Branch Rock Creek watershed. In addition, the state listed Comely Shiner (threatened) could be impacted by work within the North Branch Rock Creek watershed. Other species of state or local concern that may also be impacted by the Project occur in the Rock Creek (shingle oak, Small’s ragwort) and North Branch Rock Creek (low bindweed and shingle oak) watersheds.

3.3.7.2 RTE Time of Year Restriction

A special closure period is required by MDE and DNR, as the agency responsible for protection of the state-threatened Comely Shiner. A closure period to protect the spawning of the Comely Shiner, which only applies to North Branch Rock Creek watershed, north of Maryland Route 115, is from April 15 through July 31 during which the Design-Builder shall perform no in-stream work within these limits. No in-stream work shall be interpreted as prohibiting the Design-Builder from installing a stream diversion, dismantling a stream diversion, or performing any Work within the channel, except on the dry side of a previously established stream diversion.

3.3.7.3 RTE Avoidance and Minimization

The Design-Builder shall complete surveys before construction begins for shingle oak and Small’s ragwort within the alignment through the Rock Creek watershed and for shingle oak, low bindweed,

and trailing stitchwort through the North Branch Rock Creek watershed prior to construction to locate and determine if further avoidance and/or minimization is feasible. The Design-Builder shall complete surveys for the herbaceous Small's ragwort (May to June), trailing stitchwort (May to June), and low bindweed (June to August) during the appropriate flowering period for each species to locate and identify further avoidance and/or minimization. However, if the construction is not consistent with the flowering season, these surveys shall not delay the construction of the Project. All plants shall be marked and individuals outside of the zone of direct impact shall be protected by orange fencing or other means.

To minimize impacts to the Comely Shiner, the Design-Builder shall adhere to the best available practices, approved by the Administration, to control erosion and sediment, to prohibit in-stream construction during the closure period and to protect water quality during construction of the North Branch Rock Creek crossing. Silt loads, accidental in-stream disturbance, or other activities lending themselves to an outcome that might reduce water quality in any way shall be strictly avoided.

3.3.8 Section 4(f) Parklands

Avoidance/minimization of the parkland impacts shall include, but are not limited to: minimization of clearing and grading to the extent possible; use of BMPs for stormwater management and sediment and erosion control measures; minimization of habitat fragmentation to the extent reasonable; utilization of bridges to minimize ecological impacts; accommodation of trails; reforestation/revegetation of graded slopes and other disturbed areas; and coordination of Project design affecting parklands with the Maryland National Capital Park and Planning Commission (M-NCPPC), the Administration and the Design-Builder.

- A) Three Section 4(f) Parkland resources are identified in the Project. Parkland impacts have been identified and specific measures shall be used to avoid, minimize or mitigate impacts to parklands. The parks impact area for the Project for which mitigation is required are:
 - 1) Rock Creek Regional Park;
 - 2) North Branch Stream Valley Park; and
 - 3) Mill Creek Stream Valley Park.
- B) Minimization/mitigation measures in Park land and shown in the RFP Plans are intended to accomplish the following:
 - 1) Reduce Project footprint to the extent practicable;
 - 2) Construct retaining walls to minimize impacts, where they have previously been determined appropriate and feasible;
 - 3) Place stormwater facilities underground within the footprint of the ICC within the Special Protection Area;
 - 4) Utilize culverts designed with a deer passage cell to encourage safe wildlife crossing at select locations (see Drainage Performance Specification); and
 - 5) Maintain trail connectivity and safe passage between sections of park bisected by the Project (see Maintenance of Traffic and Planting and Landscape Architecture Performance Specification).

The Administration intends to minimize use of land in areas that were Park-land or Designated Transportation Area (DTA) adjacent to Park land prior to acquisition for this Project.

Upon Final Acceptance of Work, including completion and submission of as-built plans, the Design-Builder will be provided additional compensation for any net reduction in areas of disturbance within land that was previously Park land or DTA as stipulated herein. The incentive will be paid at \$50,000/acre with increments measured in 0.25 acre. The areas within previously owned Park-land or DTA to which this incentive applies are as follows:

- C) Right Sta. 157+50 to Sta. 182+00
- D) Left Sta. 169+80 to Sta. 176+40
- E) Left Sta. 230+00 to Sta. 245+60
- F) Right Sta. 236+60 to Sta. 245+40
- G) Left Sta. 326+10 (west of North Branch Rock Creek) to Sta. 345+10
- H) Right of Sta. 326+10 (west of North Branch Rock Creek) to Sta. 347+00

This incentive will be provided in addition to any incentive(s) paid in the affected areas for reduction in forest or wetland impacts. This additional compensation only pertains to reduced net impacts within the limits of disturbance shown on the RFP Plans. This determination will be made by comparing the net impacts determined in the as-built plans against the impacts shown on the RFP Plans.

3.4 CULTURAL RESOURCES

The Administration conducted a multi-phase Cultural Resources Management program to identify and evaluate cultural resources within the Project's Area of Potential Effects (APE). The purpose of this program was to:

- A) Identify cultural (historic and archaeological) resources listed on or eligible for the National Register of Historic Places (NRHP);
- B) Assess the potential Project effects on these resources; and
- C) Develop measures to avoid, minimize or mitigate potential adverse effects.

This program was developed in consultation with the Maryland State Historic Preservation Officer (MD-SHPO), and the Federal Highway Administration (FHWA). The treatment of the identified historic and archaeological resources was formalized in a Section 106 -Memorandum of Agreement (MOA). Refer to the CTD for specific Project requirements.

3.4.1 General Roles and Responsibilities

Except where otherwise noted below, the Administration will be responsible for conducting all cultural resources activities. These activities will include all historic and archaeological testing and data recovery, coordination with the Administration staff and consultation with all federal, state and local historic preservation agencies and public parties, including affected landowners.

- A) Unauthorized Project Impacts are prohibited;
- B) Material changes to the highway alignment that result in impact beyond those identified in the RFP Plans will not be allowed without the prior written consent of the Administration;
- C) Proposed changes shall be supported by the necessary investigations, documentation, and submittals needed for these approvals by applicable resource management agencies; and

- D) Time and cost implications resulting from design changes shall be solely borne by the Design-Builder.

3.4.2 Work Area Access During Design-Build Activities

The Design-Builder shall provide the Administration access to the work site to conduct cultural resources investigations as needed. The Design-Builder shall be responsible for coordinating an access plan that supports the timely completion of the required investigations. The Administration will make every effort to develop plans that avoid or minimize restriction of construction activities.

3.4.3 Discovered Archaeological Resources

Based on the Phase I identification study conducted by the Administration, one archeological site (18MO595-east of MD 97) was discovered within the Project, which is potentially National Historic Register-eligible and has been recommended for Phase II evaluation. The Administration will initiate the Phase II evaluations prior to any Design-Build activity and will provide the results to the Design-Builder as soon as they are known.

3.4.4 Unanticipated Discovery of Archaeological Resources

Prior to the initiation of any construction related activity, it is anticipated that all portions of the Project Limits of Disturbance (LOD) will have been the subject of formal cultural resources survey by the Administration to identify and evaluate any subsurface archaeological resources. Despite these efforts, it is possible that unidentified archaeological resources may exist within the LOD. In accordance with the stipulations of the Section 106 - MOA, the Design-Builder shall report the discovery of potentially significant archaeological resources and coordinate with the Administration for investigation and evaluation.

Any evidence of human skeletal material or burials shall require construction to stop. The occurrence shall be reported immediately to the Administration. Construction shall be suspended in the effected areas until the materials are examined and removed by appropriate archeological personnel.

Work shall be avoided in areas of significant intact subsurface archeological features such as stone/brick structural foundations, brick/stone-lined shaft features, trash filled pits and concentrated areas of burnt soil/charcoal. The Design-Builder shall immediately notify the Administration of the discovery of archeological features. The Administration will examine all reported features within 24 hours of being reported, and any necessary salvage investigations will proceed immediately, with anticipated time for examination/removal estimated as 2 to 4 working days. The Administration will be responsible for the retrieval of unanticipated artifacts. The Design-Builder shall accommodate this impact in their schedule. Excavation assistance requested from the Design-Builder will be compensated through a Contract Modification.

A number of previously identified archeological sites are known to be located in the Project area. The discovery of small amounts of low-density concentrations of scattered prehistoric and historic period cultural material, such as glass, pottery, brick, stone tools can be expected, and do not require avoidance or notification of the Administration. The Design-Builder shall consult with the Administration if there is uncertainty whether uncovered items or features are archeologically significant.

3.4.5 Mitigation of Adverse Effects to Cashell Farms

The FHWA has determined that the Project will have an adverse effect on J. H. Cashell Farm (MIHP No. M: 22-25). Refer to Section 106-MOA and Planting and Landscape Architectural Performance Specification for the details on appropriate treatment of Cashell Farm.

3.5 AIR QUALITY

3.5.1 Off-Road Diesel Emission

In 2004, EPA released the latest in a series of regulations (called Tiers) requiring off-road diesel engine companies, such as Catapillar, Detroit and International, to manufacture engines with reduced emissions. In light of significant environmental and public concerns associated with the Project, the Administration has implemented a Diesel Emissions Reduction Program. Accordingly, the Design-Builder shall prepare a plan demonstrating means and methods for compliance with the strategies below and/or prepare a similar program for review by the Administration.

3.5.2 Control Methods

Diesel powered construction equipment with engine horsepower (HP) ratings of 60HP and above that are assigned to the contract for a period in excess of 30 days, shall meet the following requirements by engine manufacturer, or be properly retrofitted with Emission Control Devices and/or use Clean Fuels in order to meet the requirements. The total off-road diesel fleet (prime contractor and subcontractors) shall meet, as a minimum, the following EPA Tiered percent usage requirements:

- A) EPA Tier 0: 0-10;
- B) EPA Tier 1: 0-60;
- C) EPA Tier 2: 20-90; and
- D) EPA Tier 3: 10-100.

All motor vehicles and/or construction equipment shall comply with all pertinent State and Federal regulations relative to exhaust emission controls and safety.

Any and all retrofit equipment shall consist of oxidation catalysts, or similar retrofit equipment control technology, that is included in the EPA Verified Retrofit Technology List.

Clean Fuels may consist of low NOx and PM emission diesel fuel.

The Design-Builder shall submit a list prior to the start of construction and each quarter during construction of the off-road 60+ HP diesel powered construction equipment which specifically demonstrates and details compliance with the numbers above. The list shall include:

- 1) The equipment number, type, make, and contractor/sub-contractor name;
- 2) Any emission control device make, model and EPA certification number; and
- 3) The type and source of fuel to be used.

Unnecessary idling of delivery and/or dump trucks, or other diesel powered equipment will not be permitted.

Noncompliance with the diesel emissions reduction program will require the Design-Builder to immediately submit a plan to regain compliance for review by the Administration. If the plan does not meet requirements and/or the Administration's comments are not satisfactorily resolved or not successfully implemented within 5 working days, the Design-Builder shall discontinue use of any and all equipment necessary to regain compliance.

3.5.3 Control of Odors and Dust

The Design-Builder shall to the best of their ability limit hazardous odors and nuisance odors

encountered or created during Work on this Contract, including odors associated with site sanitation.

The Design-Builder shall also allay dust within the Project limits. Fugitive dust (beyond Project limits) is strictly prohibited and shall be immediately addressed. Dust control shall include practices that will reduce or prevent the surface and air transport of dust during construction. Dust control measures for construction activities may include minimization of soil disturbance, applying mulch and establishing vegetation, water spraying, surface roughening, applying polymers, spray-on tackifiers, and barriers.

The practices shall be used to:

- A) Reduce wind erosion and dust,
- B) Minimize deposition of dust and wind transported soils into water bodies through run-off or wind action,
- C) Reduce respiratory problems, and
- D) Minimize low visibility conditions caused by airborne dust.

Dust Control measures shall be applied at any portion of the Project with dry exposed soils, that may be exposed to wind or vehicular traffic.

The Design-Builder shall comply with applicable federal, state and local laws, rules and regulations and permit requirements governing dust control during construction.

This specification establishes the minimum standards for design, installation, and the following performance requirements:

- 1) The implementation of dust control shall limit the area of exposed dust generation;
- 2) Asphalt and petroleum based products shall not be used for dust abatement;
- 3) Mulch and vegetation-mulch or seed and mulch may be applied to protect exposed soil from wind erosion;
- 4) Water shall be applied until the surface is wet. Repeat as needed. Water shall be applied at rates so that run-off does not occur. Treated soil surfaces that receive vehicle traffic require a stone tracking pad or tire washing at all points of access;
- 5) Polymers can be an effective practice for areas that do not receive vehicle traffic. Dry polymers shall be initially watered for activation to be effective for dust control;
- 6) Tackifiers and Soil Stabilizers Type A –Products shall be selected from and installed at rates conforming to Administration and MDE standards;
- 7) Barriers may be placed at right angles to prevailing wind currents at intervals of about 15 times the barrier height. Solid board fences, snow fences, burlap fences, crate walls, bales of hay and similar material may be used to control air currents and blown soil.; and
- 8) Tillage is a control measure performed with chisel type plows on exposed soils. Tillage shall begin on the windward side of the site and is only applicable to flat areas.

- 9) Pavement shall be regularly cleaned where trucks enter and leave the Project. If the Administration determines the Design-Builder is not performing an adequate job of controlling such sediments, the Design-Builder shall install erosion and sediment controls to preclude and adjacent aquatic resources from receiving sediment laden runoff.

The Design-Builder shall maintain opacity limits of 20% on site and 15% at the right of way line. The Design-Builder's Opacity Monitor shall be certified through EPA approved opacity training and certification course.

The Design-Builder shall document compliance by conducting regular monitoring, which is defined as daily or as reasonably requested by the Administration, in accordance with EPA standards. The Administration will be conducting quality assurance monitoring for dust control to ensure compliance.

Noncompliance with this performance specification shall require timely modification and/or mitigation of activities to bring the operation into compliance within 2 hours of discovery, or cessation of any and all operations in sufficiency to bring the overall operation into full compliance with opacity thresholds.

3.6 HAZARDOUS MATERIALS

- A) The Design-Builder shall prepare and implement a plan for management and disposal of controlled hazardous materials and contaminated soil and groundwater that may be encountered during structure demolition, land clearing, or excavation activities.
- B) The plan shall address worker safety and health in accordance with applicable federal, state, and local regulations.
- C) The plan shall provide procedures for management, handling, transportation, and disposal of demolition debris and contaminated soils and groundwater that contain controlled hazardous substances in accordance with applicable federal, state, and local regulations.
- D) Structure demolition will be required at 28 properties (21 residences, 4 state-owned properties and 2 businesses) within the Project. The Design-Builder shall perform a pre-demolition survey to determine the presence of asbestos containing materials (ACM), lead based paint (LBP), universal wastes, and other regulated materials in each structure to be demolished. Results of the pre-demolition survey will be the basis for determining appropriate methods for structure demolition and management, transportation, and disposal of demolition debris. The Design-Builder shall provide a copy of the pre-demolition survey results to the Administration for review and comment before demolition proceeds.

3.7 CONSTRUCTION ACCESS AND MOBILITY PLAN

The Design-Builder shall diligently work to minimize impact upon the local environment and community. The Design-Builder shall prepare an Access and Mobility Plan depicting major haul routes and access points. This plan shall include potential material staging areas, truck staging areas, and access routes through the Project limits. All documentation and/or permitting for off-site areas shall be the responsibility of the Design-Builder including but not limited to NEPA, NHPA, Section 7 of ESA, Section 401/404 of CWA, and MDE ESC/SWM.

The Design-Builder shall prevent the tracking of sediment onto private and public roads and shall

ensure that any sediment laden runoff is controlled to prevent entry into streams and wetlands. The Design-Builder shall prevent fugitive dust and quickly resolve dust and air quality related issues during construction.

3.7.1 Tracking of Sediment

The Design-Builder shall implement means to reduce tracking of sediment such as:

- A) Elongated and widened stabilized construction entrances;
- B) Use of wash racks;
- C) Use of street cleaning equipment;
- D) Increased maintenance of entrances; and
- E) On-site concrete wash-out pits in proximity to all major pour sites.

3.8 CONSTRUCTION NOISE AND WORK HOURS

To minimize the potential disruption of daily human activity from construction related noise yet facilitate a flexible work schedule for ICC construction in a noise-sensitive context, the Design-Builder shall implement the following noise control strategy program:

- A) Noise limit criteria, as measured from the nearest sensitive receptor* to the loudest component of a given operation:

CONSTRUCTION NOISE LIMITS IN DBA, RMS FAST					
Daytime (7 AM - 7 PM)		Evening (7 PM - 10 PM)		Night time (10 PM - 7 AM)	
Leq	Lmax	Leq	Lmax	Leq	Lmax
None	85dBA (excluding pile driving)	65 dBA Ambient+5 (whichever is louder)	85 dBA	Ambient+5 (if<60) Ambient (if>60)	Ambient

* Sensitive Receptor: An entity, geographic area, and/or structure that requires reduced noise levels to fulfill an intended purpose. Sensitive receptors include residences, nursing homes, and hospitals. Sensitive receptors also include schools, libraries, parks, and recreational areas during hours of operations or use.

- B) Proposed work from 7:00 PM on Saturdays to 7:00 AM on Mondays and all work on Holidays will be considered “Night time” hours.
- C) Pile driving shall be limited to daytime hours only (i.e. 7:00 AM to 7:00 PM) from Monday through Friday unless approved by the Administration.
- D) Pile driving shall be limited to 10:00 AM to 4:00 PM on Saturdays and prohibited on Sundays and holidays unless approved by the Administration.
- E) The Design-Builder shall notify the Administration at least 24 hours prior to working during evening hours. Notification shall include the work activity and proposed equipment, ambient and projected noise level, and noise monitoring plan.
- F) The Design-Builder shall submit a work plan for activities during night time hours to the Administration for review that documents ambient and anticipated construction

noise levels and means and methods of compliance with the noise criteria. This plan shall include ambient and anticipated noise levels, equipment to be used, public outreach, and mitigation to be used to stay within the noise threshold. The plan shall be submitted at least one week (five working days) prior to anticipated start of work. The Design-Builder shall submit a noise monitoring report 24 hours after the start of the operation to confirm compliance with the Noise Limits (ambient and construction noise data, as necessary). Additional reports shall be submitted should conditions or operational parameters increase the potential for noise upon receptors. For extended operations (longer than 5 working days) a final report shall be prepared and submitted to the Administration documenting consistent compliance with the Noise Limits.

- G) For known construction activities that will exceed the noise limits (i.e. blasting, etc.), the Design-Builder shall submit a justification for the activity, including public outreach, which must be reviewed by the Administration prior to commencing work. Potential noise reduction measures shall be considered and implemented to the extent possible and practical. The justification shall be submitted at least one week (five working days) prior to anticipated start of work.
- H) Night work shall be limited to five consecutive nights in a specific area, after which there must be a period of two consecutive nights at ambient levels or less.
- I) The Design-Builder shall consider establishing a hotel voucher program for night work which is anticipated to generate excessive noise or night work that generates valid complaints from neighboring residential areas.
- J) The Design-Builder shall construct permanent noise barriers as a first order of work, where feasible.
- K) The Design-Builder shall consider using manually adjusted or ambient sensitive back-up alarms.

The above stated construction noise criteria are applicable to Design-Builder's staging, layover, and lay down areas, as well as batch plants, casting yards, borrow/fill pits, and other areas established to fully support and facilitate construction of the ICC, which may be located beyond the Project limits-of-disturbance.

Noncompliance with this Performance Specification shall require immediate modification and/or mitigation by the Design-Builder to bring the operation into compliance or cessation of any and all operations in sufficiency to bring the overall operation into full compliance.

4.0 SUBMITTALS

The Design-Builder shall provide the following:

- A) Surveyed as-built 11x17 plans of post construction conditions in the same format as the RFP Plans and the revised impact tables that were included in the Joint State/Federal Nontidal Wetlands and Waterways Permit application.
- B) Forest Impact Plans at a frequency commensurate with the amount of forest impacted as design and construction proceeds.
- C) Environmental Compliance Plan, which includes as a minimum, within one month of limited Notice to Proceed and prior to beginning construction the following for Administration review:

- 1) Comprehensive plan of how the Design-Builder's environmental compliance team (Environmental Manager and staff and the environmental compliance firm) will achieve full compliance with the environmental commitments, considerations, permit conditions and approval requirements for design and construction.
- 2) Plan of how and where the Design-Builder's environmental compliance team will further avoid and/or minimize impacts to forests, 4(f) parklands, wetlands, and waters of the United States.
- 3) Narrative and graphics that clearly describe the Design-Builder's environmental compliance team's process, structure, organization chart identifying key environmental compliance team members under the Environmental Manager, location and methods to be used for documentation, communication and environmental QC.
- 4) A paragraph (no more than half a page each) for each of the key environmental compliance team member identified on the organization chart specifying their experience related to the Project (from the Technical Proposal submittal).
- 5) Plan of how impacts to animals (especially box turtles) will be minimized, including relocating animals and restricting access both before clearing of the Right-of-Way and during construction.
- 6) Water Quality Monitoring Plan that identifies how and where the Design-Builder will monitor water quality at the upstream and downstream Right-of-Way limit of all perennial streams within the Project.
- 7) Spill Prevention Control and Countermeasures Plan (SPCC) and Stormwater Pollution Prevention Plan in accordance with CFR and COMAR
- 8) Air Quality Plan (Off Road Diesel Emissions Reduction Program).
- 9) Hazardous Materials Plan.
- 10) Access and Mobility Plan.
- 11) Environmental Compliance and Awareness Training Program



Maryland Department of Transportation

*State Highway Administration
Baltimore, Maryland
Competitive Sealed Proposals
Step 2: Request for Proposals (RFP)*

Contract No. AT3765960

F.A.P. No. *(See Cover Sheet)*

**ICC CONTRACT 'A'
DESIGN-BUILD PROJECT**

MD 200

From I-270/I-370 to MD 97

Montgomery County

Part 4, Special Provisions

THIS PAGE INTENTIONALLY BLANK

**SPECIAL PROVISIONS
INDEX**

SP 103	PROJECT HUB OFFICE
SP 109	BASELINE SCHEDULE
SP 111	COORDINATION OF CONTRACTORS
SP 112	CSXT REQUIREMENTS
SP 113	RIGHT OF WAY PROVISIONS
SP 114	PRICE ADJUSTMENTS
SP 115	KEY MANAGER AND KEY PERSONNEL RESPONSIBILITIES
SP 116	NOTICE TO PROCEED
SP 117	DECK OVER STRUCTURES
SP 118	HAZARDOUS MATERIALS
SP 119	EMERGENCY VEHICLE ACCESS RAMPS
SP 120	RESTORATION OF GEOTECHNICAL STAGING AREA

SECTION 115 – KEY MANAGERS AND KEY PERSONNEL QUALIFICATIONS REQUIREMENTS

In the qualifications specified below, the word “shall” indicates a required minimum qualification. The word “should” indicates the Administration’s preferred qualifications, but such qualification is not a mandatory requirement. Refer to Special Provision 103-Project Hub Office and Field Offices for location requirements relative to the performance of their functions.

Principal-in-Charge: Key person who shall be designated at the discretion of the Design-Builder and shall have the authority to represent, make decisions for, and oversee the performance of the Design-Builder. Should have demonstrated a minimum of fifteen (15) years experience in construction and management of construction on highway projects that included work of a similar scope, nature, and complexity as included in this Project. The Principal-in-Charge shall have Design-Build experience.

Project Manager: Key manager who shall have a minimum of ten (10) years demonstrated experience in construction and management on in construction and management of construction on highway projects with similar size, type of work, and complexity as this Project, including environmental sensitivity, compressed timelines, and community information requirements. The Project Manager can only hold this one key manager position. The Project Manager shall possess Design-Build experience and extensive project management experience.

Project Quality Manager: Key manager who shall be under the authority of the Design-Builder’s corporate management or JV Board with overall responsibility for development and management of the Design-Builder’s Quality Plan and responsible for the overall Quality Control program, including the quality of management, design and construction. The Project Quality Manager may be an employee of a consultant firm, not the QC Engineer or Designer. The Project Quality Manager shall be a registered professional engineer and shall have demonstrated experience in highway design and/or construction with at least ten (10) years experience in quality assurance/quality control activities, including preparation and implementation of Quality Plans, and procedures for design and/or construction. The Project Quality Manager shall only hold this key manager position. The Project Quality Manager shall possess significant experience with the Administration’s quality control system and documentation.

Environmental Manager: Key manager who shall be the designated by the Design-Builder and under the authority of the Design-Builder’s Project Manager, with overall responsibility for environmental compliance of the Project during design and construction. The Environmental Manager may be an employee of a consultant firm of the Designer. The Environmental Manager shall have a minimum of ten (10) years demonstrated experience in environmental permitting, environmental design, construction management, and compliance on large complex transportation projects in environmentally sensitive areas. The Environmental Manager should have experience in managing others in environmental activities. The Environmental Manager shall have experience with highway engineering drawings and concepts, and shall have experience working cooperatively and effectively with design engineers and construction staff.

Construction Manager: Shall be a registered professional engineer and shall have demonstrated construction experience in civil works projects with experience in managing site work on large, complex highway construction projects. Experience shall include work of the nature anticipated for this Project, and should include design/build, public and environmental sensitivity, utility relocation, and maintenance of traffic. The Construction Manager shall have a minimum of ten (10) years demonstrated experience in

construction and management of construction on highway projects that included work of similar scope, nature, and complexity as this Project.

Design Manager: Shall be a Maryland-registered professional engineer who is an owner or employee of the Designer. The Design shall have a minimum of fifteen (15) years demonstrated experience in managing design for multi-disciplinary highway projects of similar scope and complexity as this Project. The Design Manager shall possess significant experience with highway design, bridges, design in environmentally sensitive (natural and community) areas, retaining structures, drainage structures, and projects of similar type, magnitude and complexity as this Project. The Design Manager shall have Design-Build experience.

Community Outreach Manager: Shall have demonstrated public outreach and public facilitator experience for major transportation projects in environmentally sensitive community areas. The Community Outreach Manager shall have demonstrated experience in organizing and participating in public forums, notification of construction activities to the public, and documentation of interface with the public. The Community Outreach Manager should have experience in managing others in public relations activities. The Community Outreach Manager should be familiar with highway engineering drawings and concepts and working cooperatively and effectively with design engineers and construction staff.

Design Quality Control Manager: Shall be a Maryland-registered professional engineer who is an employee of the Designer or a firm on the design team. The Design QC Manager shall have a minimum of eight (8) years documented experience in QC/QA activities on large highway design projects with similar scope and complexity of the Project.

Construction Quality Control Manager: Shall be a Maryland-registered professional engineer who is an employee of the independent firm responsible for construction QC. The Construction Quality Control Manager shall possess a minimum of eight (8) years documented experience in QC/QA activities, including management of construction QC programs, on large highway construction projects that have incorporated the type of construction included in this Project.

Safety Manager: The Design-Builder shall designate a primary Safety representative who will report directly to the Design-Builder's Project Manager. The Safety Manager shall be dedicated to this Project and have no other duties or job assignments on this Project. The Safety Manager shall have a minimum of three (3) years documented experience managing a safety program similar to the magnitude and complexity of this project.

Environmental Stream and Wetlands Specialist: Shall be designated by the Design-Builder and shall be under the authority of the Environmental Manager, with a minimum of ten (10) years of practical stream restoration, fish passage restoration and wetland identification and construction experience. The Environmental Stream Wetland Specialist should have experience in natural channel design, Rosgen Stream Classification Systems, stream diversions, stream and fish relocations, wetland delineations, water quality monitoring, RTE species identification, proficiency in working with survey data and instruments, grading operations, grade controls and planting operations. The Environmental Stream and Wetland Specialist shall be familiar with Maryland streams, soils and plants.

Utilities Coordinator: Shall have demonstrated experience with a minimum of five (5) years of practical experience in utility design, construction and coordination for the types of utilities encountered on this Project. The Utilities Coordinator shall have significant experience in utility designations, coordination with utility agencies, right-of-way requirements, and preparation of as-built drawings.

Lead Geotechnical Engineer: Shall be a Maryland-registered professional engineer who is an employee of the Designer or a firm on the design team. The Lead Geotechnical Engineer shall have a minimum of ten (10) years documented experience in geotechnical investigations and design on highway projects that included work of a similar scope, nature, and complexity as this Project.

Maintenance of Traffic Manager: Shall be a Maryland-registered professional engineer with ten (10) years of practical experience with consulting firms or government agencies on projects of similar magnitude and complexity. Shall be continuously available during construction until Final Completion. The Maintenance of Traffic Manager shall have demonstrated working knowledge of traffic signal timing, construction traffic control on freeways, construction work zone traffic safety, the Manual of Uniform Traffic Control Devices (MUTCD), computer simulation and optimization models, and freeway management techniques. The Maintenance of Traffic Manager shall have successfully completed the Administration approved Temporary Traffic Control Traffic Managers Training Course.

Traffic Engineer: Shall be a Maryland-registered professional engineer and ITE licensed Professional Traffic Operations Engineer with a minimum of ten (10) years of documented and progressive experience in traffic analysis (including computer traffic simulation and optimization models), traffic control device design (signing, signals, pavement markings, lighting), traffic signal timing, and freeway traffic management techniques. The Traffic Engineer shall have demonstrated experience in design of traffic control devices for public agencies, and shall have passed the Maryland Traffic Management Course.

Landscape Architect. Shall be a Maryland licensed Landscape Architect with ten (10) years of documented and progressively responsible architectural design experience related to highway corridor design and construction. The Landscape Architect shall have demonstrated working knowledge and experience with the implementation process for Context Sensitive Design/Solutions, be familiar with native vegetation of the Mid-Atlantic Region, be familiar with the requirements of the Maryland reforestation law and Maryland Forest Conservation Act, and be familiar with stormwater management/bioretention planting.

Lead H&H Engineer: Shall be a Maryland-registered professional engineer who is an employee of the Designer or a firm on the design team. The Lead H&H Engineer shall have a minimum of fifteen (15) years documented experience in water resources engineering including hydrology and hydraulic investigations, analysis and design. The Lead H&H Engineer shall have documented experience with the MDE (non-tidal wetlands, waterways, water quality certification, erosion and sediment control, and storm water management), FEMA and US Army Corps of Engineers (CWA Section 401 and 404) permitting and design requirements.

Erosion and Sediment Control Manager: Shall be designated by the Design-Builder and shall report directly to the Construction Manager. The Erosion and Sediment Control Manager shall be Maryland State Highway Administration “Yellow Card” certified to demonstrate successful completion of the Administration’s “Erosion and Sediment Control Training for Contractors and Inspectors”. The Erosion and Sediment Control Manager shall have a minimum of eight (8) years documented experience in erosion and sediment control (ESC) design, construction, inspection, or a combination of ESC design construction and inspection for construction of similar magnitude and environmental sensitivity as this Project.

Project Controls Manager: Shall have demonstrated experience in development of Work Breakdown Structures (WBS), scheduling and schedule analysis, cost estimating and cost control, budget development, reporting, and record/document control, as well as the implementation of Earned Value

methodologies. The Project Controls Manager shall have demonstrated high level reporting skills plus experience in developing and updating schedules with a minimum of seven (7) years of documented experience in project controls for design and construction activities similar in magnitude and complexity as this Project. Experience with Primavera 5.0 for Engineering & Construction is preferred. The Project Controls Manager should possess a Bachelor degree in Business Administration, Construction Management or related field. Advanced knowledge of cost engineering concepts is highly desirable.

Lead Scheduler: Shall have demonstrated critical path method scheduling skills and the ability to develop complex construction schedules, perform monthly updates, analyze schedules to determine duration and logic issues and have an understanding of cost and resource loaded schedules. The Lead Scheduler shall be familiar with change impact analysis and be well versed in Primavera scheduling products. Experience with Primavera 5.0 for Engineering & Construction is preferred. The Lead Scheduler shall possess a degree in Construction Management or a related field, and a minimum of seven (7) years documented scheduling experience in highway construction of similar magnitude and complexity as this Project.

Lead ITS/ETC Engineer: Shall be a Maryland-registered professional engineer or shall be a Maryland-registered professional engineer within 6 months of Contract Award with a minimum of ten (10) years experience of progressively responsible experience in Intelligent Transportation Systems (ITS) and Electronic Toll Collection (ETC) design, construction, operations, and maintenance,. The Lead ITS/ETC Engineer shall have demonstrated experience with the National ITS Architecture and advanced knowledge of Electronic Toll Collection systems.

Lead Pavement Specialist: Shall be a Maryland-registered professional engineer and shall have a minimum of five (5) years of documented experience in pavement investigation, pavement type selection, new pavement design, pavement rehabilitation design and material selection.

Lead Structures Engineer: Shall be a Maryland-registered professional engineer and shall be the responsible for all structural design efforts. The Lead Structures Engineer shall have a minimum of fifteen (15) years demonstrated experience in the design of a structures, including steel and concrete bridges, scour analysis, abutments, approach slabs, deep foundations, bearings, top-down retaining walls, noise barriers and culverts.

Bridge Engineer for BR-17 (concrete arch bridge over Rock Creek): Shall be a Maryland-registered professional engineer and shall be the responsible engineer for the design of bridge structure BR-17. The Bridge Engineer for BR 17 shall have a minimum of fifteen (15) years demonstrated experience in the design of concrete arch bridges of similar magnitude and complexity as bridge structure BR-17, including construction sequence, erection procedures, calculation of construction loads and design of false-work.

Lead Roadway Engineer: Shall be a Maryland-registered professional engineer who is an employee of the Designer or firm or the design team. The Lead Roadway Engineer shall have a minimum of ten (10) years documented experience in the planning and design for highway projects with a similar scope, nature and complexity as this Project. The Lead Roadway Engineer shall have strong experience in the selection and application of AASHTO roadway design guidelines and experience coordinating the multi-disciplinary elements of the roadway typical section.



Maryland Department of Transportation



DESIGN BUILD

COMPETITIVE SEALED PROPOSALS
PROCUREMENT
STEP TWO: REQUEST FOR PROPOSALS
(RFP)

PLANS OF PROPOSED HIGHWAY

S.H.A. CONTRACT NO. AT3765960

FEDERAL AID PROJECT NO. AC-NH-ICC-1(1)N

INTERCOUNTY CONNECTOR (ICC) CONTRACT 'A' I-270 / I-370 TO MD 97

FINAL: JULY 2006

(A) LIMIT OF WORK
ICC
STATION 6+20+05

(B) LIMIT OF WORK
ICC
STATION 45+00

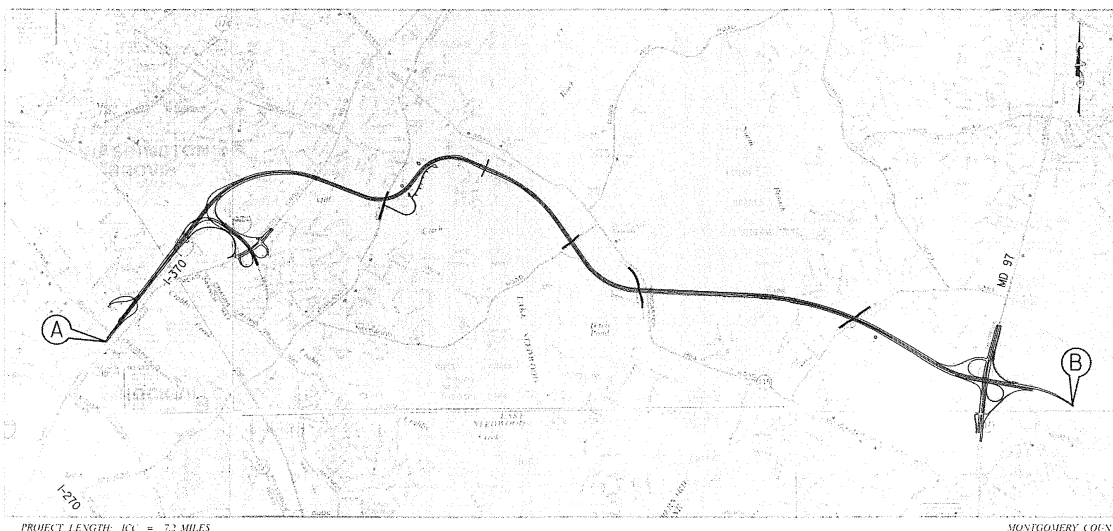

PROJECT LENGTH: ICC = 32 MILES

MONTGOMERY COUNTY



REVIEWED AND APPROVAL RECOMMENDED

APPROVAL RECOMMENDED

APPROVED



SHA

- Maryland Transportation Authority
- Maryland State Highway Administration

TITLE SHEET

July 2006

Plate G-1

INDEX OF ICC CONTRACT A RFP PLANS

PLATE NO. DESCRIPTION

GENERAL INFORMATION

- G-1 TITLE SHEET
- G-2 INDEX SHEET
- G-3 ABBREVIATIONS AND LEGEND
- G-4 PLAN DEFINITIONS

ROADWAY STANDARD DETAILS

- RSD-1 ONE AND TWO LANE EXIT RAMP DETAILS
- RSD-2 ONE AND TWO LANE ENTRANCE RAMP DETAILS

TYPICAL SECTIONS

- TS-1 ONE & TWO LANE RAMP TYPICAL SECTIONS & ROUNDING DETAIL
- TS-2 ICC MAINLINE - 30' MEDIAN & 36' MEDIAN TYPICAL SECTIONS
- TS-3 ICC MAINLINE - 36' MEDIAN & 50' MEDIAN W/BIKE PATH TYPICAL SECTIONS
- TS-4 ICC MAINLINE - 26' MEDIAN TYPICAL SECTIONS
- TS-5 ICC MAINLINE - 50' MEDIAN & METRO ACCESS ROAD
- TS-6 MD 97 TYPICAL SECTIONS
- TS-7 EMORY LANE & FUTURE CRABBS BRANCH WAY TYPICAL SECTIONS
- TS-8 NEEDWOOD ROAD & MUNCASTER MILL ROAD TYPICAL SECTIONS
- TS-9 OLDE MILL RUN & OVERHILL ROAD TYPICAL SECTIONS
- TS-10 REDLAND ROAD TYPICAL SECTIONS

ROADWAY PLANS

- RP-1 STA 5000+00 TO STA 5060+00 ROADWAY CONCEPT PLAN
- RP-2 STA 5060+00 TO STA 150+00 ROADWAY CONCEPT PLAN
- RP-3 STA 150+00 TO STA 215+00 ROADWAY CONCEPT PLAN
- RP-4 STA 215+00 TO STA 265+00 ROADWAY CONCEPT PLAN
- RP-5 STA 265+00 TO STA 315+00 ROADWAY CONCEPT PLAN
- RP-6 STA 315+00 TO STA 345+00 ROADWAY CONCEPT PLAN
- RP-7 STA 345+00 TO STA 385+00 ROADWAY CONCEPT PLAN
- RP-8 STA 385+00 TO STA 415+00 ROADWAY CONCEPT PLAN
- RP-9 STA 415+00 TO STA 472+00 CONTRACT B CONCEPT PLAN

ROADWAY PROFILES

- PR-1 ICC MAINLINE STA 5020+00 TO STA 104+00 ROADWAY PROFILE
- PR-2 ICC MAINLINE STA 104+00 TO STA 156+00 ROADWAY PROFILE
- PR-3 ICC MAINLINE STA 156+00 TO STA 210+00 ROADWAY PROFILE
- PR-4 ICC MAINLINE STA 210+00 TO STA 262+00 ROADWAY PROFILE
- PR-5 ICC MAINLINE STA 262+00 TO STA 314+00 ROADWAY PROFILE
- PR-6 ICC MAINLINE STA 314+00 TO STA 348+00 ROADWAY PROFILE
- PR-7 ICC MAINLINE STA 348+00 TO STA 398+00 ROADWAY PROFILE
- PR-8 ICC MAINLINE STA 398+00 TO STA 430+00 ROADWAY PROFILE
- PR-9 M.A.R. RAMP B & M.A.R. RAMP A PROFILES
- PR-10 M.A.R. RAMP C PROFILE
- PR-11 M.A.R. RAMP D, RAMP E, RAMP F & RAMP F1 PROFILES
- PR-12 M.A.R. RAMP G, RAMP H & RAMP I PROFILES
- PR-13 MD 355 RAMP L & MD 355 RAMP M PROFILES
- PR-14 MD 97 RAMP A, MD 97 RAMP B & MD 97 RAMP C PROFILES
- PR-15 MD 97 RAMP CC, MD 97 RAMP D & MD 97 RAMP E PROFILES
- PR-16 MD 97 RAMP F & MD 97 ROADWAY PROFILES
- PR-17 MD 97 ROADWAY PROFILE
- PR-18 REDLAND ROAD & OVERHILL ROAD PROFILES
- PR-19 OVERHILL ROAD EXTENDED PROFILE
- PR-20 OLDE MILL RUN ROAD & NEEDWOOD ROAD PROFILES
- PR-21 MUNCASTER MILL ROAD & EMORY LANE PROFILES

BRIDGE KEY PLANS

- SG-1 KEY PLAN - 1
- SG-2 KEY PLAN - 2

BR-1 (I-370/ICC Over MD 355)

- S1-1 GENERAL PLAN AND ELEVATION
- S1-2 SITE INFORMATION
- S1-3 TYPICAL SECTION

PLATE NO. DESCRIPTION

BR-2 (I-370/ICC Over Ramp M)

- S2-1 GENERAL PLAN AND ELEVATION
- S2-2 SITE INFORMATION
- S2-3 TYPICAL SECTION

BR-3 (Ramp L Over Ramp M)

- S3-1 GENERAL PLAN AND ELEVATION
- S3-2 SITE INFORMATION
- S3-3 TYPICAL SECTION

BR-4 (I-370/ICC Over Oakmont Avenue)

- S4-1 GENERAL PLAN AND ELEVATION
- S4-2 SITE INFORMATION
- S4-3 TYPICAL SECTION

BR-5 (I-370/ICC Over CSXT/MARC)

- S5-1 GENERAL PLAN AND ELEVATION
- S5-2 SITE INFORMATION
- S5-3 TYPICAL SECTION

BR-6 (Ramp B Over Crabbs Branch Way)

- S6-1 GENERAL PLAN AND ELEVATION
- S6-2 SITE INFORMATION
- S6-3 TYPICAL SECTION

BR-7 (ICC Over Crabbs Branch Way)

- S7-1 GENERAL PLAN AND ELEVATION
- S7-2 SITE INFORMATION
- S7-3 TYPICAL SECTION

BR-8 (Ramp A Over Crabbs Branch Way)

- S8-1 GENERAL PLAN AND ELEVATION
- S8-2 SITE INFORMATION
- S8-3 TYPICAL SECTION

BR-9 (Ramp A Over ICC)

- S9-1 GENERAL PLAN AND ELEVATION
- S9-2 SITE INFORMATION
- S9-3 PIER PLAN AND ELEVATION
- S9-4 TYPICAL SECTION

BR-10 (Ramp A Over Ramp C)

- S10-1 GENERAL PLAN AND ELEVATION
- S10-2 SITE INFORMATION
- S10-3 TYPICAL SECTION

BR-11 (Ramp H Over Ramp C)

- S11-1 GENERAL PLAN AND ELEVATION
- S11-2 SITE INFORMATION
- S11-3 TYPICAL SECTION

BR-13 (ICC Over Ramp C)

- S13-1 GENERAL PLAN AND ELEVATION
- S13-2 SITE INFORMATION
- S13-3 TYPICAL SECTION

BR-14 (ICC Over Shady Grove Road)

- S14-1 GENERAL PLAN AND ELEVATION
- S14-2 SITE INFORMATION
- S14-3 TYPICAL SECTION

PLATE NO. DESCRIPTION

BR-15 (Redland Road Over ICC)

- S15-1 GENERAL PLAN AND ELEVATION
- S15-2 SITE INFORMATION
- S15-3 PIER PLAN AND ELEVATION
- S15-4 TYPICAL SECTION

BR-16 (Olde Mill Run Deck Over)

- S16-1 GENERAL PLAN AND ELEVATION-1
- S16-2 GENERAL PLAN AND ELEVATION-2
- S16-3 GENERAL PLAN AND ELEVATION-3
- S16-4 GENERAL PLAN AND ELEVATION-4
- S16-5 SITE INFORMATION-1
- S16-6 SITE INFORMATION-2
- S16-7 SECTIONS AND DETAILS
- S16-8 CONCEPTUAL GRADING PLAN AND ELEVATION-1
- S16-9 CONCEPTUAL GRADING PLAN AND ELEVATION-2
- S16-10 CONCEPTUAL GRADING PLAN AND ELEVATION-3
- S16-11 CONCEPTUAL GRADING PLAN AND ELEVATION-4
- S16-12 RENDERING

BR-17 (ICC Over Rock Creek)

- S17-1 GENERAL PLAN AND ELEVATION
- S17-2 RENDERING
- S17-3 SITE INFORMATION
- S17-4 CAP BEAM 1 PLAN, ELEVATION AND SECTION
- S17-5 CAP BEAM 2 PLAN, ELEVATION AND SECTION
- S17-6 TYPICAL SECTION

BR-18 (Needwood Road Over ICC)

- S18-1 GENERAL PLAN AND ELEVATION
- S18-2 SITE INFORMATION
- S18-3 PIER PLAN AND ELEVATION
- S18-4 TYPICAL SECTION

BR-19 (Muncaster Mill Road Over ICC)

- S19-1 GENERAL PLAN AND ELEVATION
- S19-2 SITE INFORMATION
- S19-3 PIER PLAN AND ELEVATION
- S19-4 TYPICAL SECTION

BR-20 (ICC Over North Branch Of Rock Creek)

- S20-1 GENERAL PLAN AND ELEVATION
- S20-2 SITE INFORMATION
- S20-3 TYPICAL SECTION

BR-21 (ICC Over Trib. Of North Branch Of Rock Creek)

- S21-1 GENERAL PLAN AND ELEVATION
- S21-2 SITE INFORMATION
- S21-3 TYPICAL SECTION

BR-22 (Emory Lane Over ICC)

- S22-1 GENERAL PLAN AND ELEVATION
- S22-2 SITE INFORMATION
- S22-3 PIER PLAN AND ELEVATION
- S22-4 TYPICAL SECTION

BR-23 (MD 97 Over ICC)

- S23-1 GENERAL PLAN AND ELEVATION
- S23-2 SITE INFORMATION
- S23-3 TYPICAL ABUTMENT
- S23-4 PIER 1 PLAN AND ELEVATION
- S23-5 PIER 2 PLAN AND ELEVATION
- S23-6 TYPICAL SECTION

PLATE NO. DESCRIPTION

STRUCTURAL STANDARDS

- SS-51 ABUTMENT, WINGWALL AND FENCE DETAILS
- SS-52 PARAPET AND PILASTER DETAILS
- SS-53 PARAPET DETAILS
- SS-54 PARAPET DETAILS
- SS-55 BICYCLE BARRIER DETAILS
- SS-56 GIRDER HAUNCH GEOMETRY DETAILS
- SS-57 STRIP SEAL JOINT DETAILS
- SS-58 SLOPE PROTECTION DETAILS
- SS-59 CONCRETE COATING
- SS-S10 RETAINING WALL, HEAD WALL, AND LIGHT POLE DETAILS
- SS-S11 CANTILEVER SIGN STRUCTURE
- SS-S12 OVERHEAD SIGN STRUCTURE
- SS-S13 HIKER/BIKER PATH TRANSITION AT BRIDGE

CONCEPT BRIDGE RENDERINGS

- SF-1 GRANITE OVERPASS
- SF-2 STONE OVERPASS
- SF-3 GATEWAY OVERPASS
- SF-4 NOISE BARRIERS
- SF-5 SIGN STRUCTURES

LANDSCAPE PLANS

- LS-00 LANDSCAPE KEY SHEET
- LS-01 STA 5020+25 TO STA 5040+50 LANDSCAPE CONCEPT PLAN
- LS-02 STA 5040+50 TO STA 104+00 LANDSCAPE CONCEPT PLAN
- LS-03 STA 104+00 TO STA 133+50 LANDSCAPE CONCEPT PLAN
- LS-04 M.A.R. STA 1116+50 TO STA 1102+00 LANDSCAPE CONCEPT PLAN
- LS-05 STA 133+50 TO STA 162+50 LANDSCAPE CONCEPT PLAN
- LS-06 STA 162+50 TO STA 191+00 LANDSCAPE CONCEPT PLAN
- LS-07 STA 191+00 TO STA 220+00 LANDSCAPE CONCEPT PLAN
- LS-08 STA 220+00 TO STA 250+00 LANDSCAPE CONCEPT PLAN
- LS-09 STA 250+00 TO STA 279+50 LANDSCAPE CONCEPT PLAN
- LS-10 STA 279+50 TO STA 306+50 LANDSCAPE CONCEPT PLAN
- LS-11 STA 306+50 TO STA 319+00 LANDSCAPE CONCEPT PLAN
- LS-12 STA 319+00 TO STA 347+00 LANDSCAPE CONCEPT PLAN
- LS-13 STA 347+00 TO STA 376+00 LANDSCAPE CONCEPT PLAN
- LS-14 MD 97 STA 224+00 TO STA 238+50 LANDSCAPE CONCEPT PLAN
- LS-15 STA 376+00 TO STA 405+50 LANDSCAPE CONCEPT PLAN
- LS-16 MD 97 STA 208+50 TO STA 47+50 LANDSCAPE CONCEPT PLAN
- LS-17 STA 405+50 TO STA 415+00 LANDSCAPE CONCEPT PLAN
- LS-18 LANDSCAPE CONCEPT PLAN
- LS-19 LANDSCAPE CONCEPT PLAN

INTELLIGENT TRANSPORTATION SYSTEM (ITS) PLANS

- ITS-1 ITS CONCEPT PLAN
- ITS-2 ITS CONCEPT PLAN
- ITS-3 ITS CONCEPT PLAN
- ITS-4 ITS CONCEPT PLAN

ELECTRONIC TOLL COLLECTION PLANS

- ETC-1 TOLL GANTRY PLAN
- ETC-2 TOLL GANTRY ELEVATION
- ETC-3 TOLL GANTRY SECTIONS
- ETC-4 TOLL GANTRY RENDERING
- ETC-5 TOLL GANTRY CONCEPT PLAN



• Maryland Transportation Authority
• Maryland State Highway Administration

ADMINISTRATIVE PLAN



**CONTRACT A
AT3765960
INDEX OF RFP PLANS**

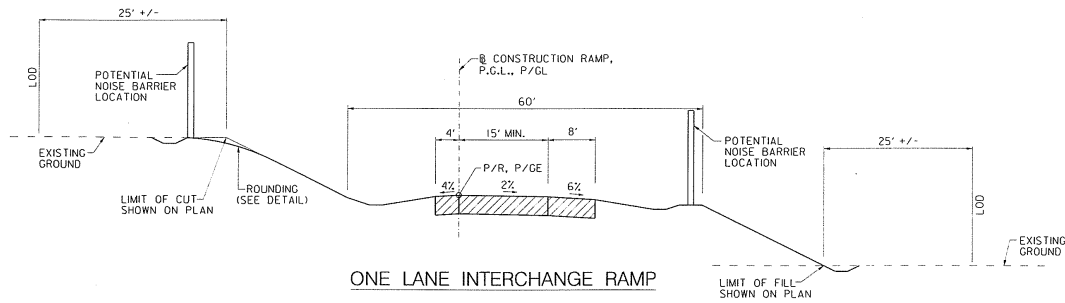

ONE LANE INTERCHANGE RAMP

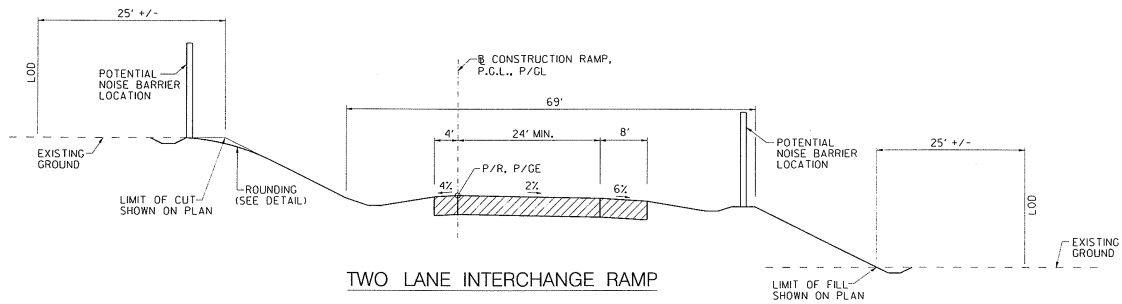

TWO LANE INTERCHANGE RAMP

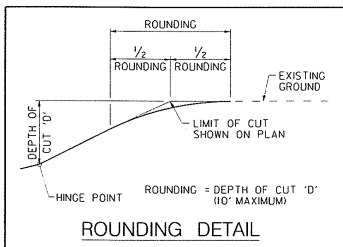

ROUNDING DETAIL

NOTE: STATION LIMITS; NUMBER OF LANES; TYPICAL CROSS SLOPES; LANE, SHOULDER, AND MEDIAN WIDTHS ARE DIRECTIVE. OTHER ELEMENTS SHOWN ARE INDICATIVE.



SHA

- Maryland Transportation Authority
- Maryland State Highway Administration

DIRECTIVE PLAN

NOT TO SCALE





CONTRACT A
AT3765960
TYPICAL SECTIONS

July 2006

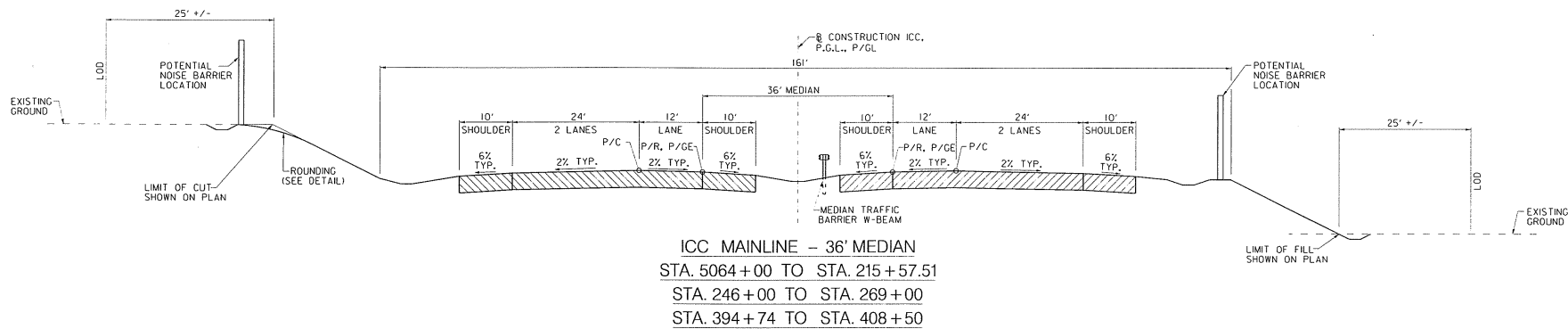
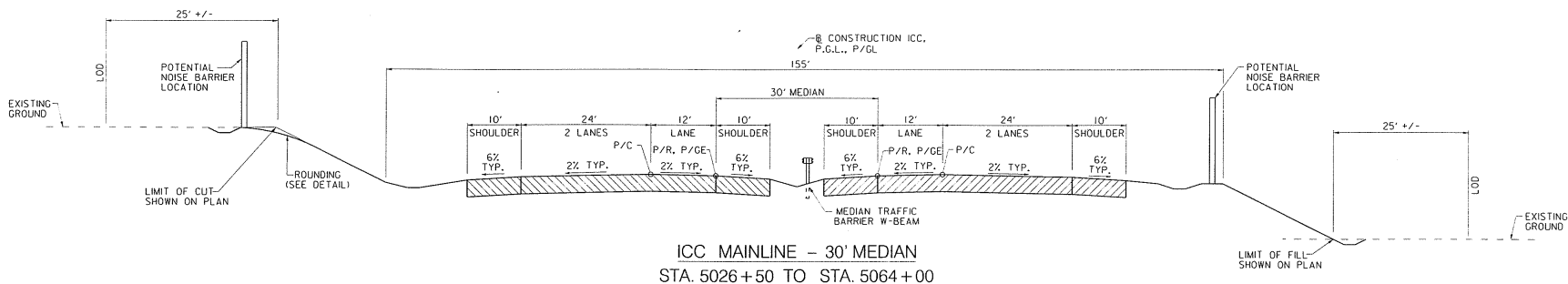
Plate TS-1



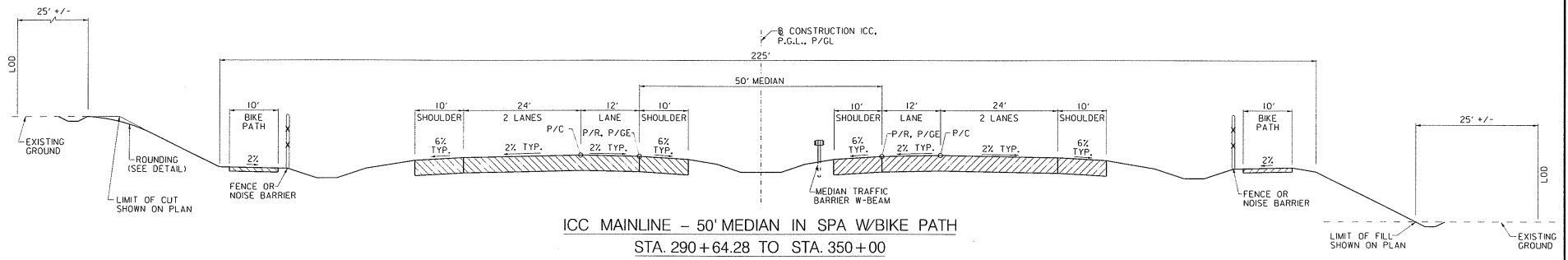
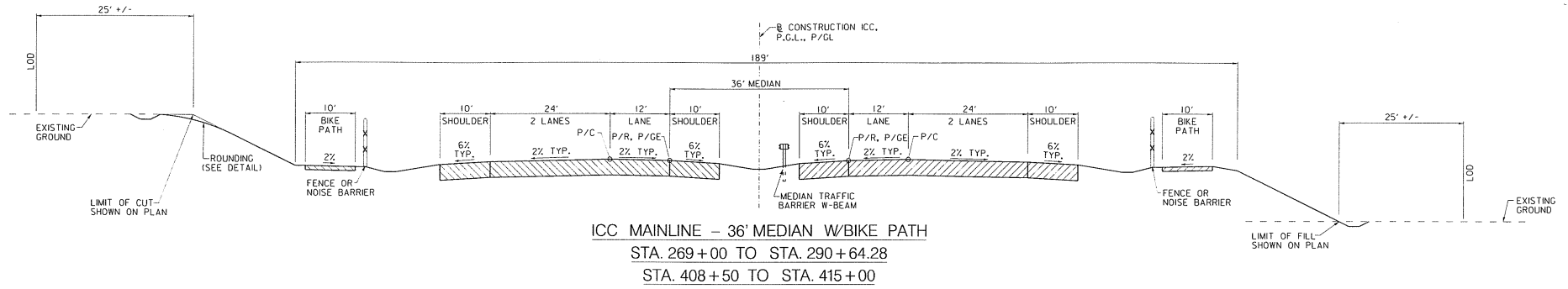

NOTE: STATION LIMITS; NUMBER OF LANES; TYPICAL CROSS SLOPES; LANE, SHOULDER, AND MEDIAN WIDTHS ARE DIRECTIVE. OTHER ELEMENTS SHOWN ARE INDICATIVE.

  <ul style="list-style-type: none"> • Maryland Transportation Authority • Maryland State Highway Administration 	DIRECTIVE PLAN NOT TO SCALE	 CONTRACT A AT3765960 TYPICAL SECTIONS July 2006 Plate TS-2
---	---	--



NOTE: STATION LIMITS; NUMBER OF LANES; TYPICAL CROSS SLOPES; LANE, SHOULDER, PATH, AND MEDIAN WIDTHS ARE DIRECTIVE. OTHER ELEMENTS SHOWN ARE INDICATIVE.

  <ul style="list-style-type: none"> • Maryland Transportation Authority • Maryland State Highway Administration 	DIRECTIVE PLAN NOT TO SCALE	 CONTRACT A <i>AT3765960</i> TYPICAL SECTIONS July 2006 Plate TS-3
---	---	--

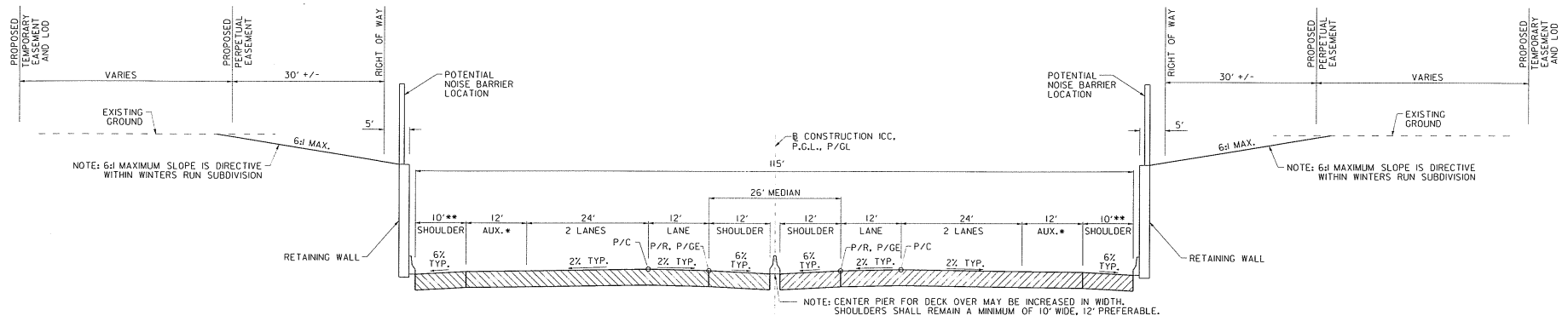

ICC MAINLINE - 26' MEDIAN AT WINTERS RUN
 STA. 215+57.51 TO STA. 246+00
 (AREAS WITH RETAINING WALLS
 AND AREA WITH DECKOVER)

* NOTE: RETAINING WALLS, DECKOVER, AND BRIDGE SHALL ACCOMMODATE FUTURE AUXILIARY LANES FOR M-63. SEE ROADWAY PERFORMANCE SPECIFICATION FOR DETAILS.

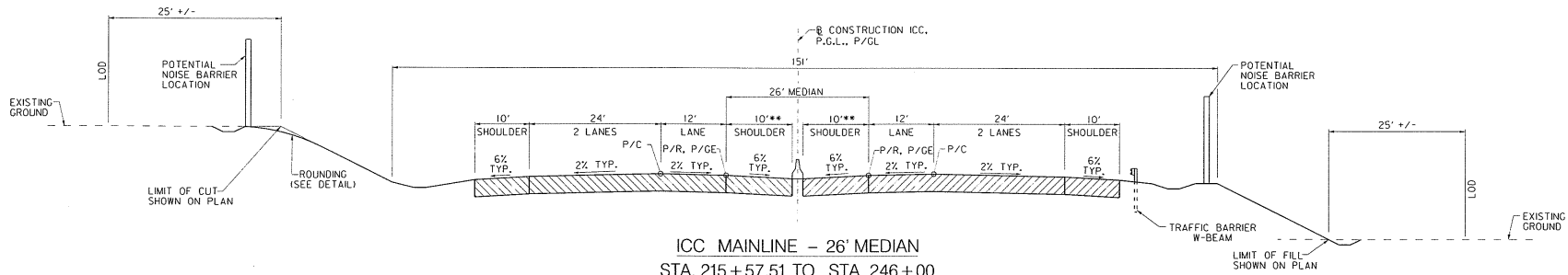

ICC MAINLINE - 26' MEDIAN
 STA. 215+57.51 TO STA. 246+00
 (OPEN SECTION AREAS)

** NOTE: 10' MINIMUM, 12' IS DESIRABLE.
 NOTE: STATION LIMITS; NUMBER OF LANES; TYPICAL CROSS SLOPES; LANE, SHOULDER, AND MEDIAN WIDTHS ARE DIRECTIVE. OTHER ELEMENTS SHOWN ARE INDICATIVE.



SHA

- Maryland Transportation Authority
- Maryland State Highway Administration

DIRECTIVE PLAN

NOT TO SCALE



CONTRACT A
 AT3765960
TYPICAL SECTIONS

July 2006

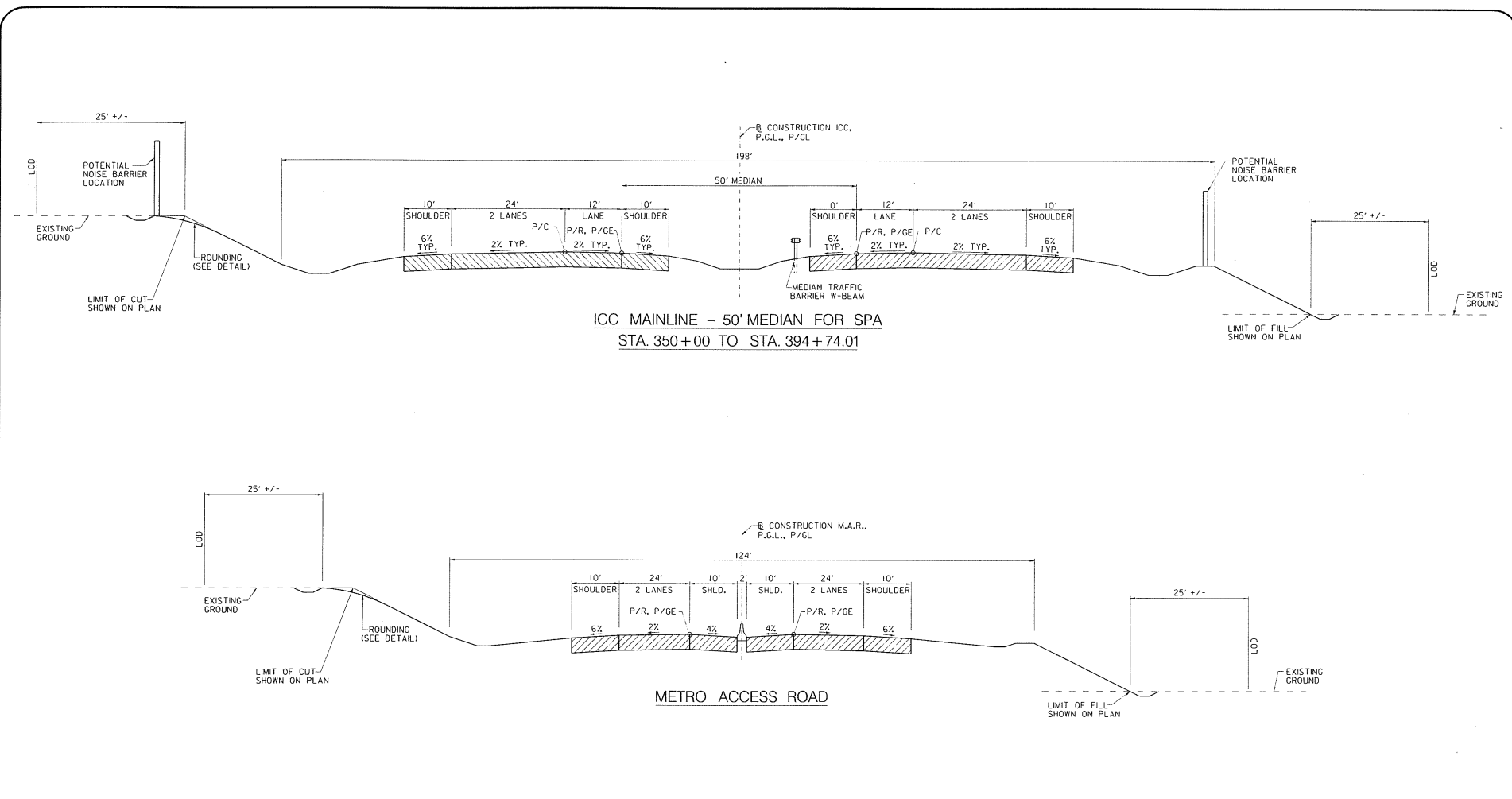

Plate TS-4



ICC MAINLINE - 50' MEDIAN FOR SPA
 STA. 350+00 TO STA. 394+74.01

METRO ACCESS ROAD

NOTE: STATION LIMITS; NUMBER OF LANES; TYPICAL CROSS SLOPES; LANE, SHOULDER, AND MEDIAN WIDTHS ARE DIRECTIVE. OTHER ELEMENTS SHOWN ARE INDICATIVE.

 <p>SHA</p> <ul style="list-style-type: none"> Maryland Transportation Authority Maryland State Highway Administration 	<p>DIRECTIVE PLAN</p> <p>NOT TO SCALE</p>	 <p>CONTRACT A AT3765960 TYPICAL SECTIONS</p> <p>July 2006 Plate TS-5</p>
---	--	--

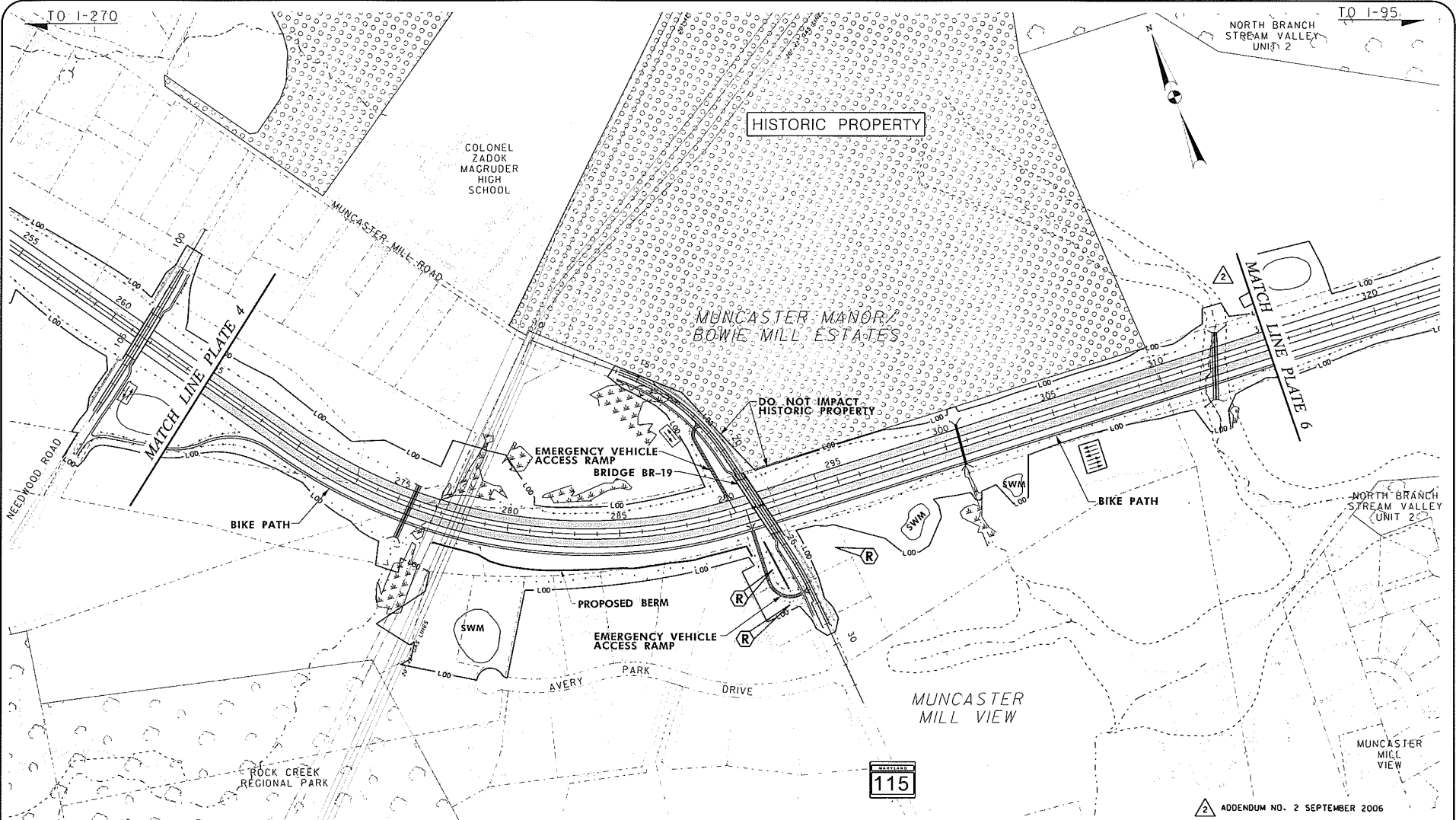

NOTE: PROPERTY BOUNDARIES SHOWN ON THIS PLAN ARE BASED ON TAX MAP RECORDS AND MAY NOT BE ACCURATE. ALIGNMENT AND GRADES REFLECTED ON ROADWAY CONCEPT PLANS AND ROADWAY PROFILE PLANS DEPICT THE BASIC PROJECT CONFIGURATION FOR MAINLINE, CROSS STREETS, AND SERVICE ROADS.

SHA

- Maryland Transportation Authority
- Maryland State Highway Administration

INDICATIVE PLAN

SCALE IN FEET

INTERCOUNTY
CONNECTOR
ICC

CONTRACT A
AT3765960

ROADWAY CONCEPT PLAN

Sta. 265+00 To Sta. 315+00

July 2006 Plate RP-5

ADDENDUM NO. 2 SEPTEMBER 2006

m:\projects\2005\05050_P5\NC400\Contract Plans\0517.dwg 03/23/07

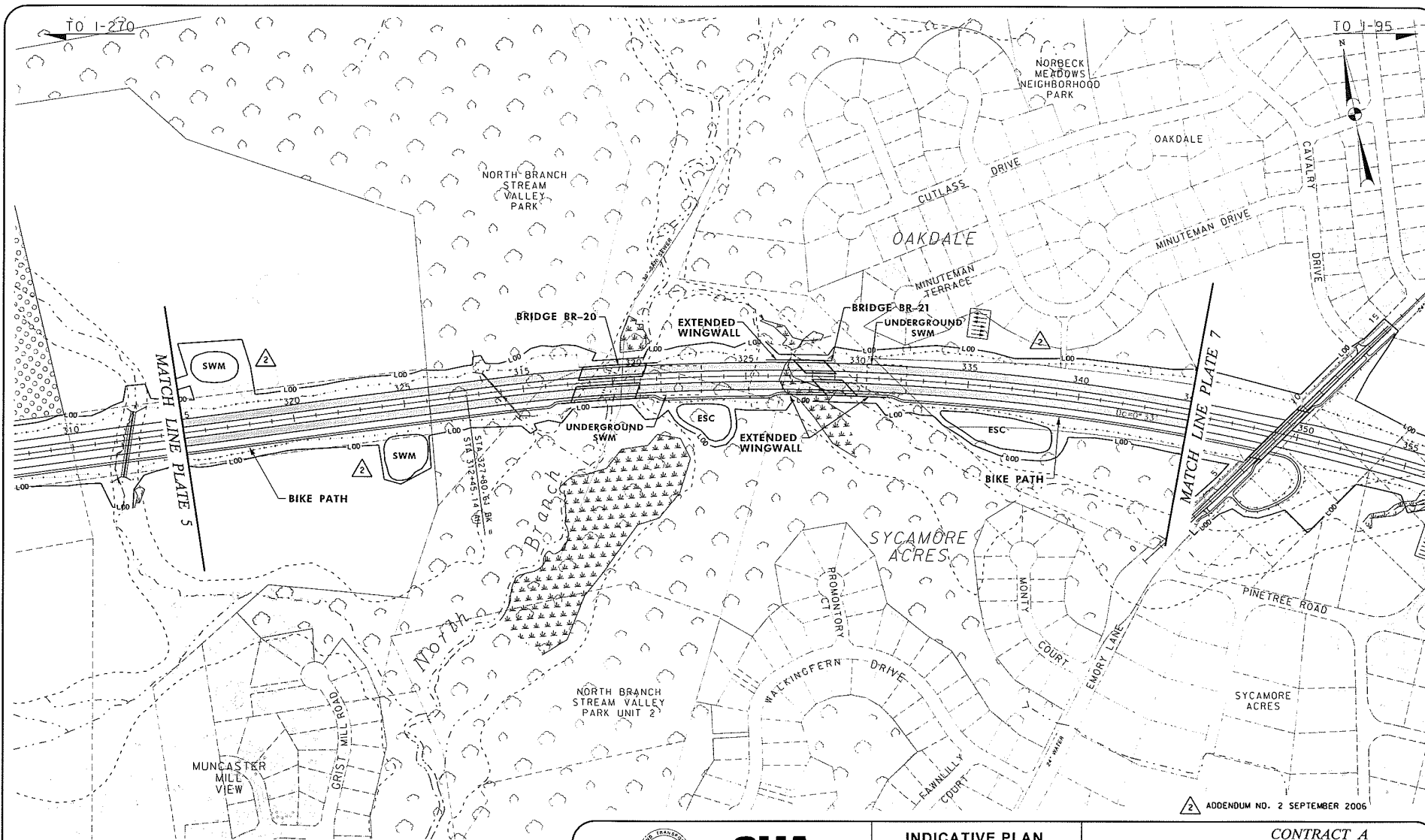

ADDENDUM NO. 2 SEPTEMBER 2006

NOTE: PROPERTY BOUNDARIES SHOWN ON THIS PLAN ARE BASED ON TAX MAP RECORDS AND MAY NOT BE ACCURATE. ALIGNMENT AND GRADES REFLECTED ON ROADWAY CONCEPT PLANS AND ROADWAY PROFILE PLANS DEPICT THE BASIC PROJECT CONFIGURATION FOR MAINLINE, CROSS STREETS, AND SERVICE ROADS.



SHA

- Maryland Transportation Authority
- Maryland State Highway Administration

INDICATIVE PLAN

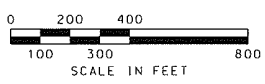

INTERCOUNTY CONNECTOR
ICC

CONTRACT A
AT3765960
ROADWAY CONCEPT PLAN

Sta. 315+00 To Sta. 345+00

July 2006

Plate RP-6

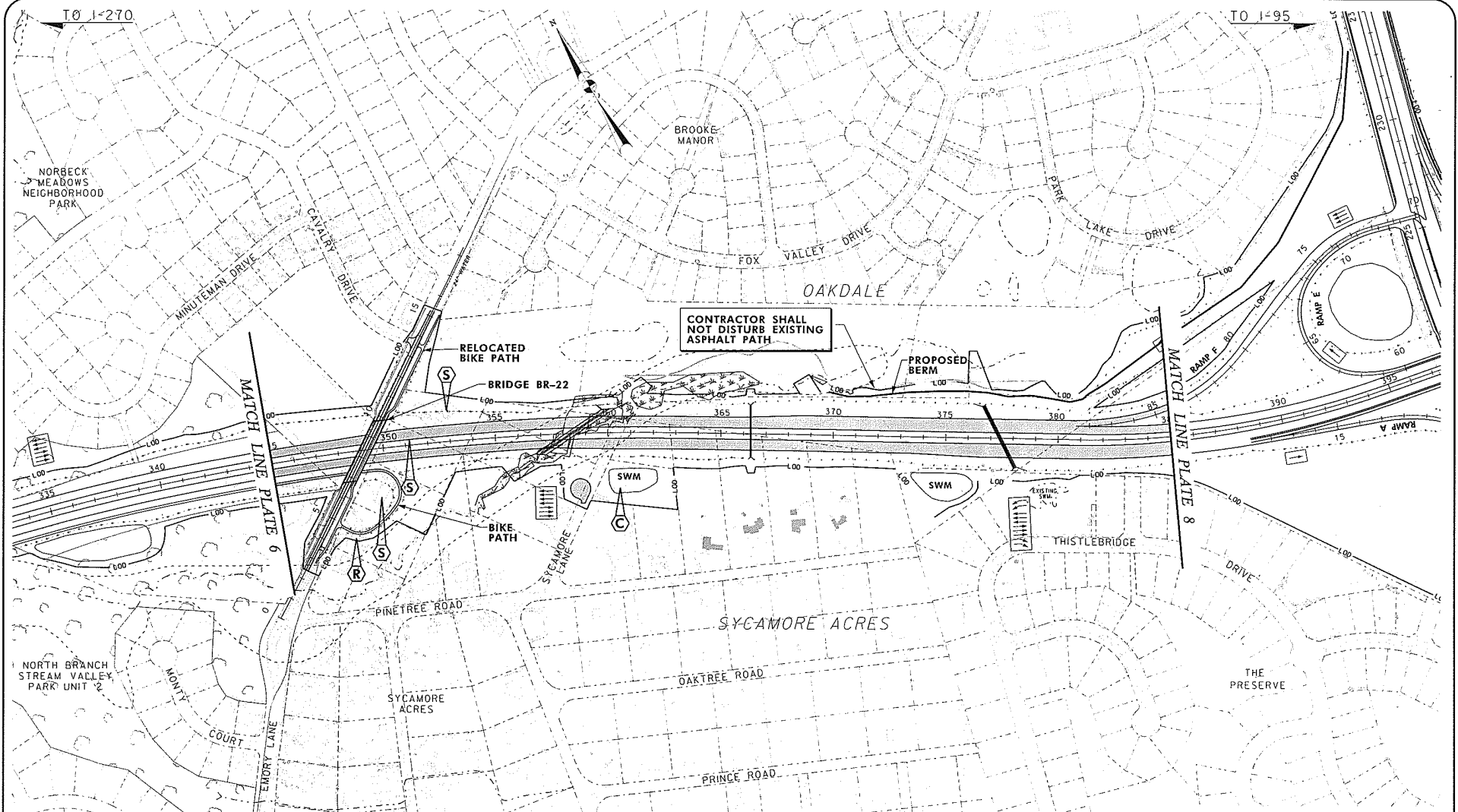

NOTE: PROPERTY BOUNDARIES SHOWN ON THIS PLAN ARE BASED ON TAX MAP RECORDS AND MAY NOT BE ACCURATE. ALIGNMENT AND GRADES REFLECTED ON ROADWAY CONCEPT PLANS AND ROADWAY PROFILE PLANS DEPICT THE BASIC PROJECT CONFIGURATION FOR MAINLINE, CROSS STREETS, AND SERVICE ROADS.



SHA

- Maryland Transportation Authority
- Maryland State Highway Administration

INDICATIVE PLAN

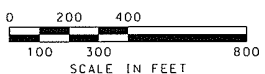

INTERCOUNTY CONNECTOR
ICC

CONTRACT A
AT3765960
ROADWAY CONCEPT PLAN

Sta. 345+00 To Sta. 385+00

July 2006

Plate RP-7

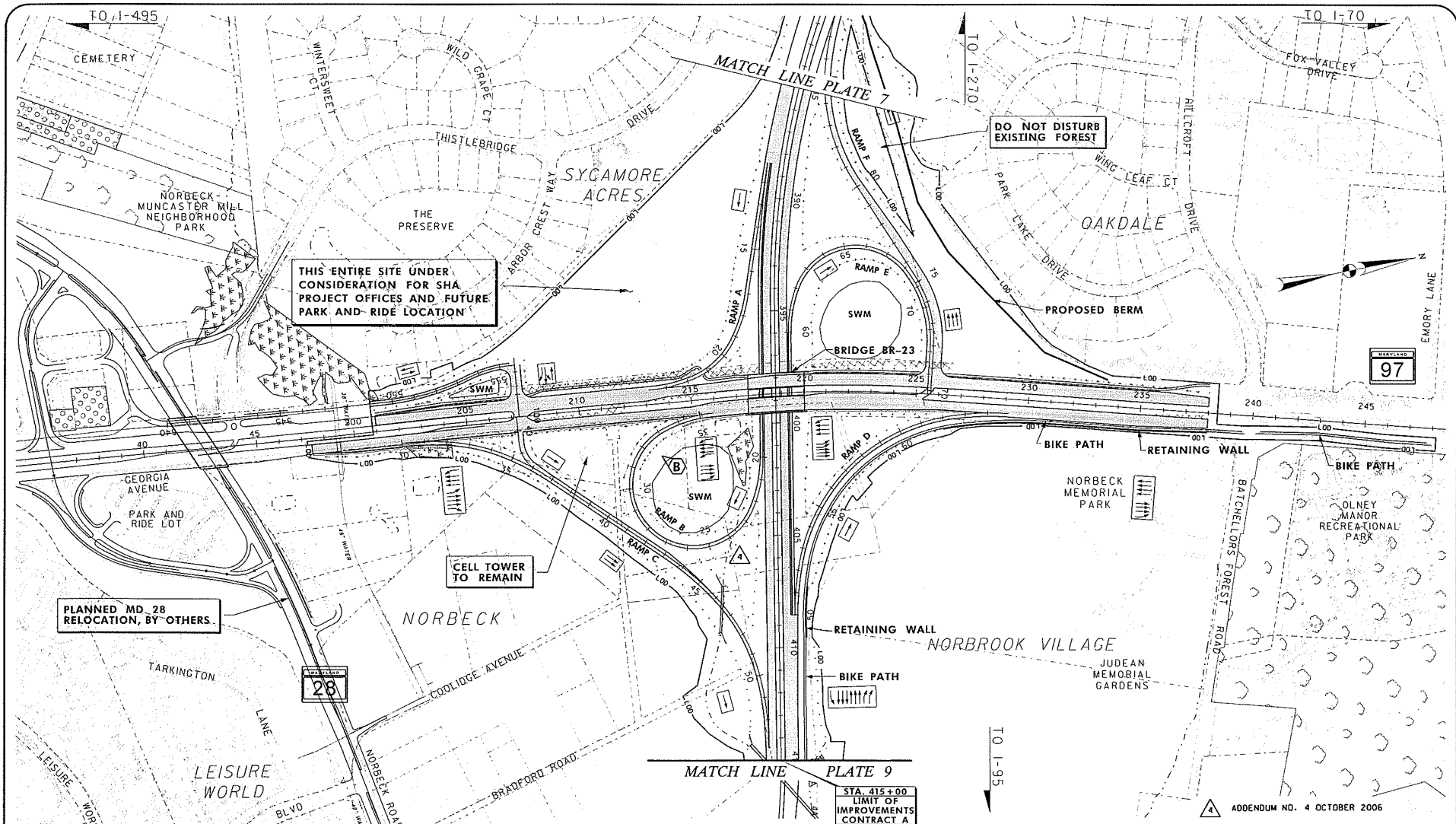

SHA

- Maryland Transportation Authority
- Maryland State Highway Administration

INDICATIVE PLAN

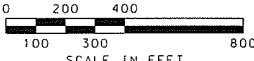

SCALE IN FEET

CONTRACT A
AT3765960

ICC

INTERCOUNTY CONNECTOR

ROADWAY CONCEPT PLAN

Sta. 385+00 To Sta. 415+00

July 2006 Plate RP-8

MAXIMUM
PROFILE ELEVATION
INCREASE/DECREASE

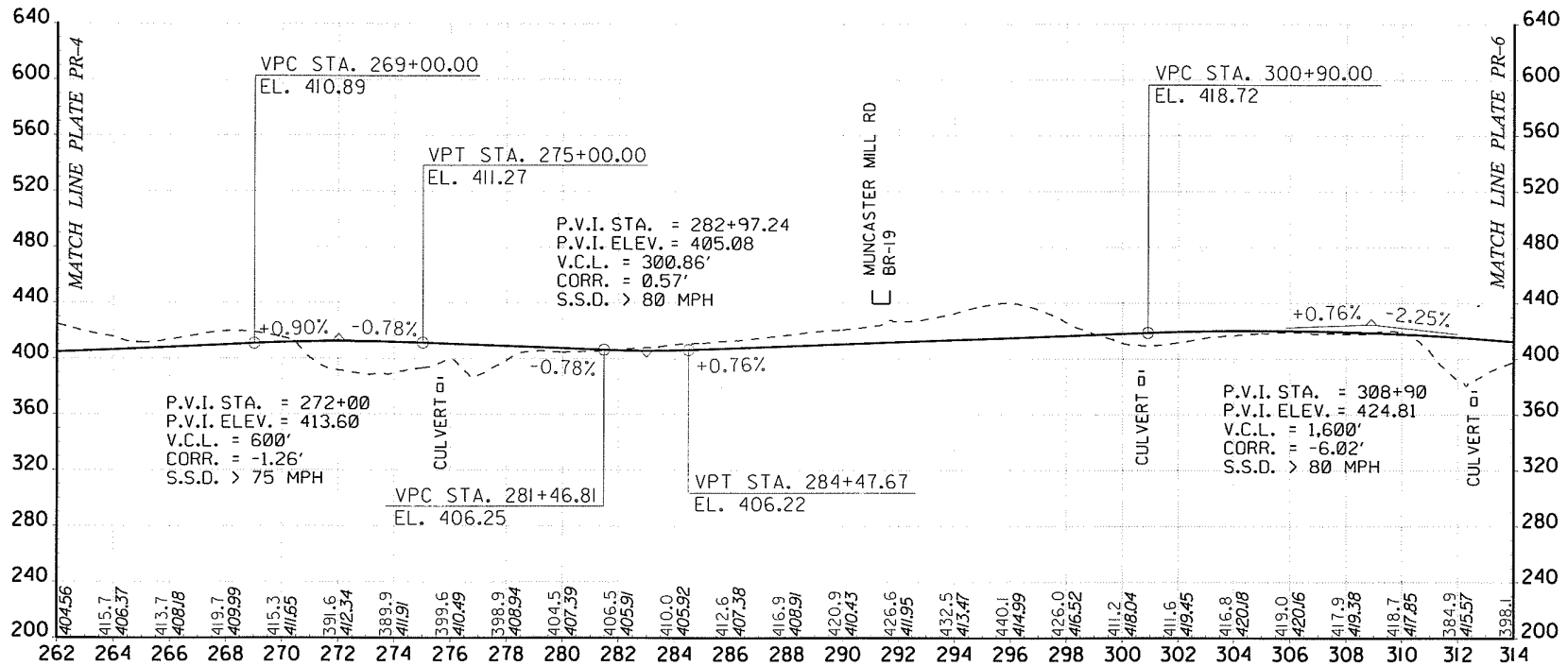

INTERCOUNTY CONNECTOR

NOTE: MODIFICATION OF THE PROFILE WITHIN THE LIMITS SHOWN ON THIS PLAN AND IN ACCORDANCE WITH THE SPECIFICATIONS, PERMITS AND PROJECT COMMITMENTS WILL BE CONSIDERED IN CONFORMANCE WITH THE BASIC PROJECT CONFIGURATION. STA 276+00 TO STA 281+00 DESIGN-BUILDER SHALL COORDINATE WITH GAS TRANSMISSION RELOCATION PLANS. ALIGNMENT AND GRADES REFLECTED ON ROADWAY CONCEPT PLANS AND ROADWAY PROFILE PLANS DEPICT THE BASIC PROJECT CONFIGURATION FOR MAINLINE, CROSS STREETS, AND SERVICE ROADS.



SHA

- Maryland Transportation Authority
- Maryland State Highway Administration

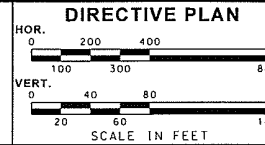

INTERCOUNTY
CONNECTOR
ICC

CONTRACT A
AT3765960
ROADWAY PROFILE PLAN
Sta. 262+00 To Sta. 314+00

July 2006

Plate PR-5

MAXIMUM
PROFILE ELEVATION
INCREASE/DECREASE

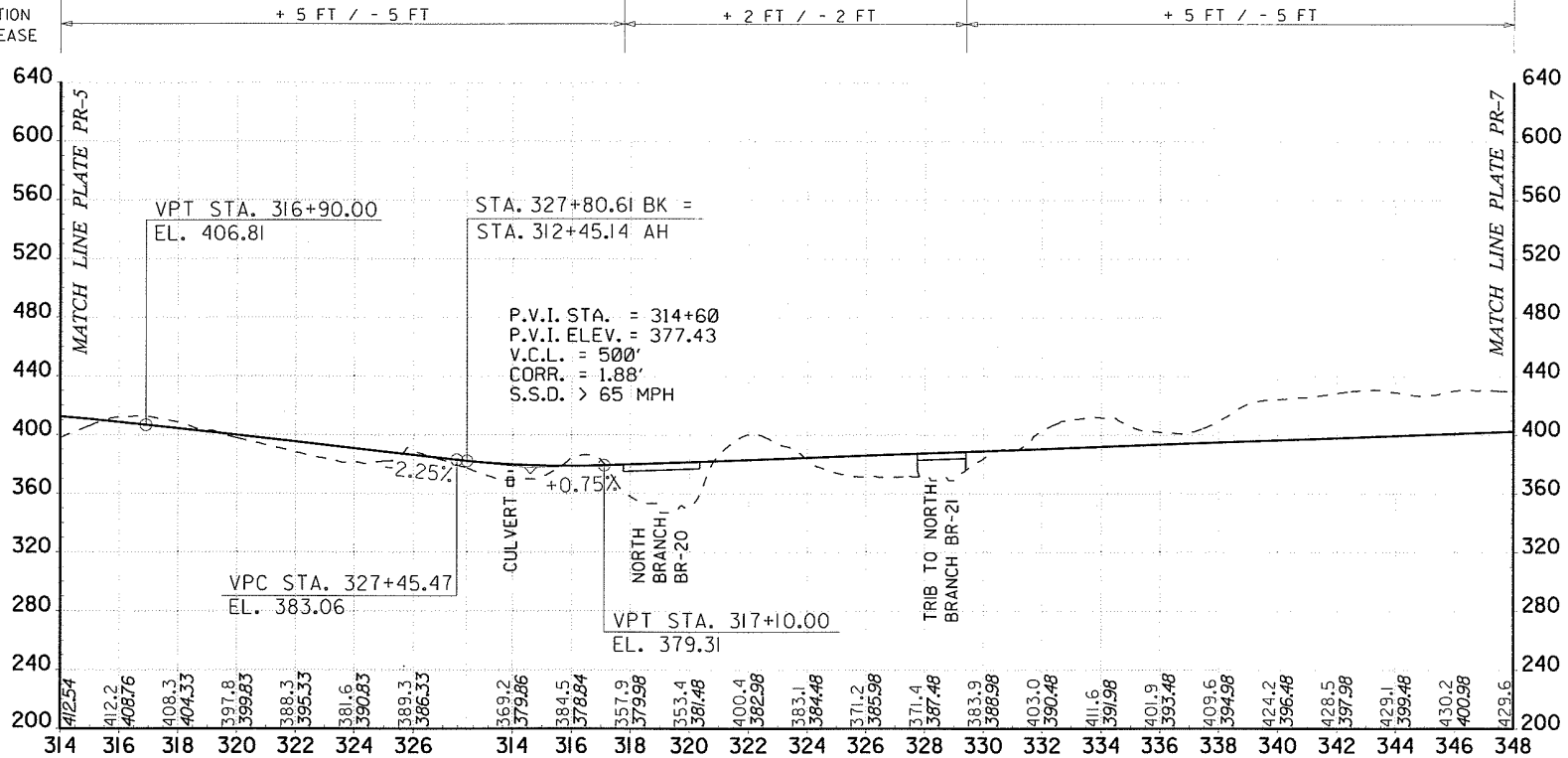

INTERCOUNTY CONNECTOR

NOTE: MODIFICATION OF THE PROFILE WITHIN THE LIMITS SHOWN ON THIS PLAN AND IN ACCORDANCE WITH THE SPECIFICATIONS, PERMITS AND PROJECT COMMITMENTS WILL BE CONSIDERED IN CONFORMANCE WITH THE BASIC PROJECT CONFIGURATION. ALIGNMENT AND GRADES REFLECTED ON ROADWAY CONCEPT PLANS AND ROADWAY PROFILE PLANS DEPICT THE BASIC PROJECT CONFIGURATION FOR MAINLINE, CROSS STREETS, AND SERVICE ROADS.



SHA

- Maryland Transportation Authority
- Maryland State Highway Administration

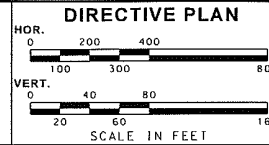

INTERCOUNTY
CONNECTOR
ICC

CONTRACT A
AT3765960
ROADWAY PROFILE PLAN
Sta. 314+00 To Sta. 348+00

July 2006

Plate PR-6

MAXIMUM
PROFILE ELEVATION
INCREASE/DECREASE

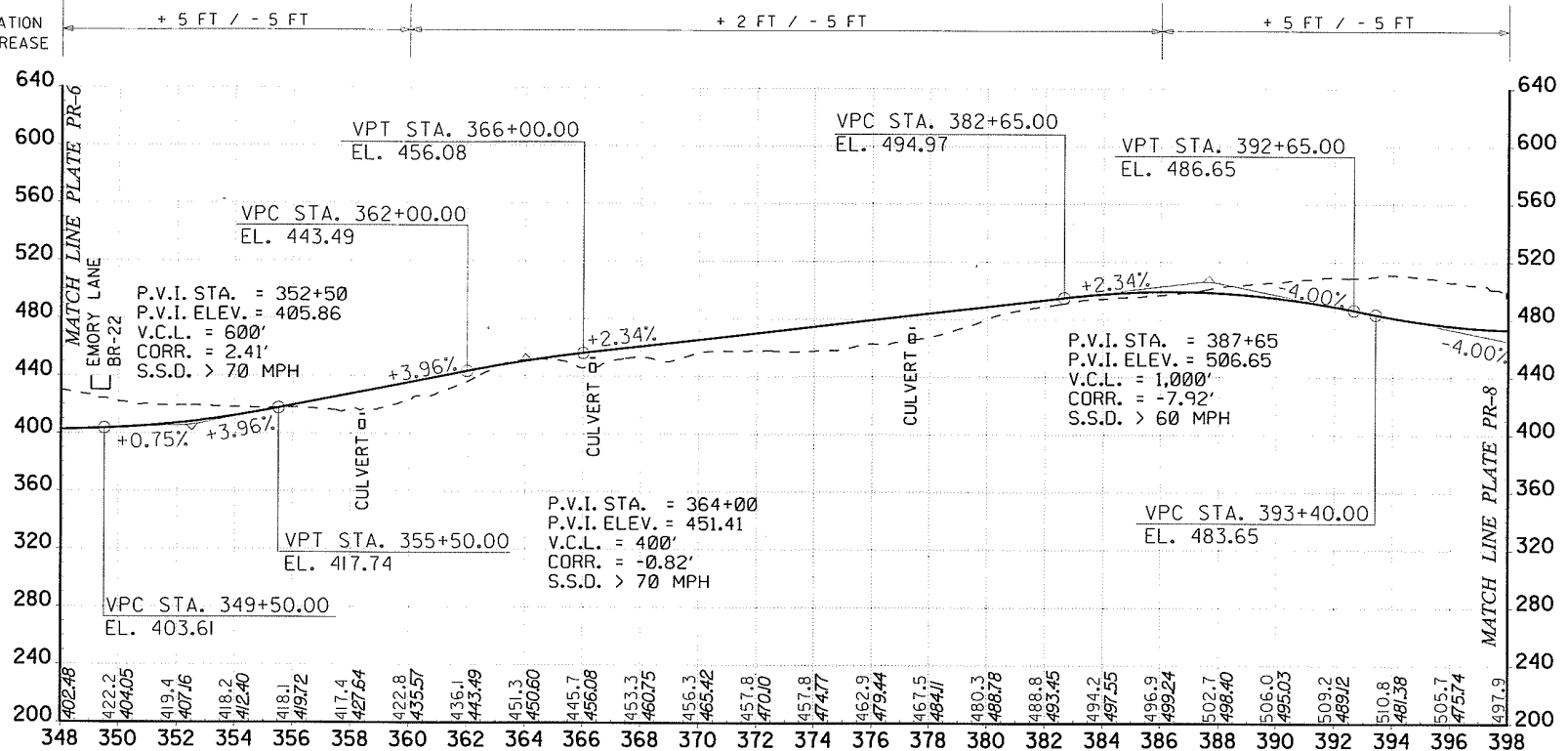

INTERCOUNTY CONNECTOR

NOTE: MODIFICATION OF THE PROFILE WITHIN THE LIMITS SHOWN ON THIS PLAN AND IN ACCORDANCE WITH THE SPECIFICATIONS, PERMITS AND PROJECT COMMITMENTS WILL BE CONSIDERED IN CONFORMANCE WITH THE BASIC PROJECT CONFIGURATION. ALIGNMENT AND GRADES REFLECTED ON ROADWAY CONCEPT PLANS AND ROADWAY PROFILE PLANS DEPICT THE BASIC PROJECT CONFIGURATION FOR MAINLINE, CROSS STREETS, AND SERVICE ROADS.

- Maryland Transportation Authority
- Maryland State Highway Administration

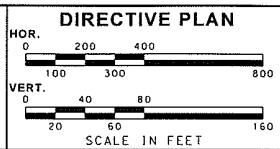

INTERCOUNTY CONNECTOR
ICC

CONTRACT A
AT3765960
ROADWAY PROFILE PLAN
 Sta. 348+00 To Sta. 398+00
 July 2006 Plate PR-7

m:\projects\2005\05050_10n\roads\contract_a\pr06\1fcd.dgn

MAXIMUM
PROFILE ELEVATION
INCREASE/DECREASE

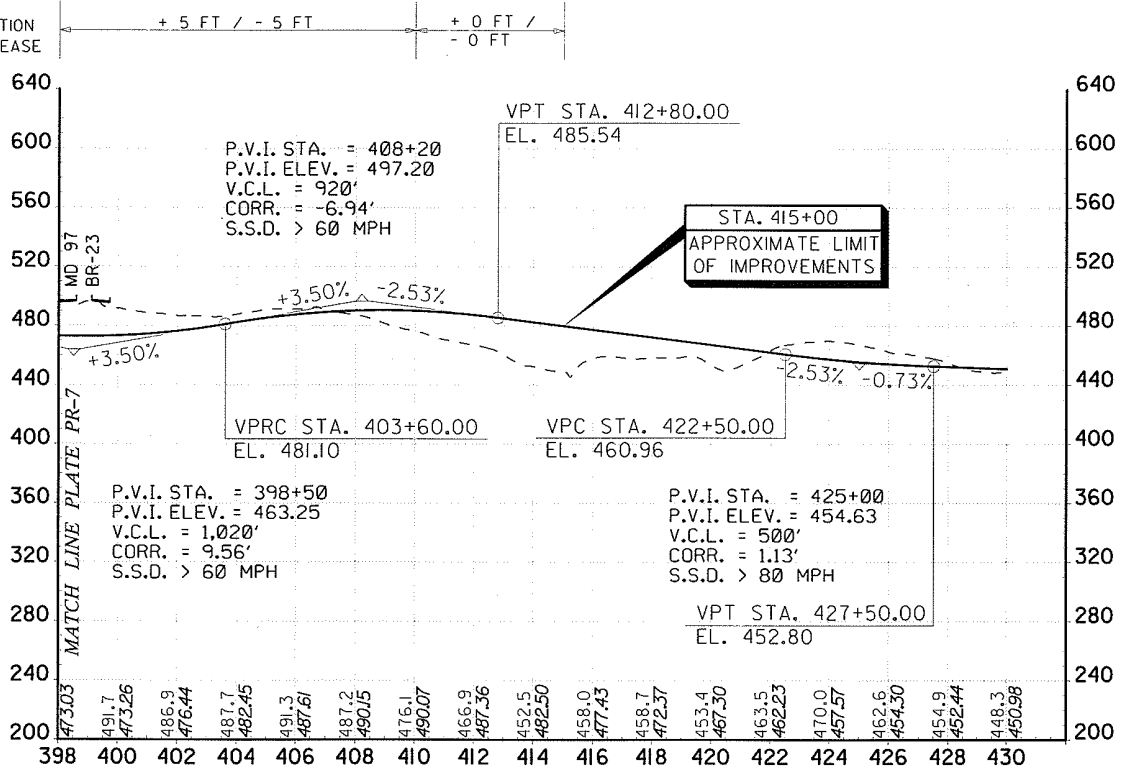

INTERCOUNTY CONNECTOR

NOTE: MODIFICATION OF THE PROFILE WITHIN THE LIMITS SHOWN ON THIS PLAN AND IN ACCORDANCE WITH THE SPECIFICATIONS, PERMITS AND PROJECT COMMITMENTS WILL BE CONSIDERED IN CONFORMANCE WITH THE BASIC PROJECT CONFIGURATION. ALIGNMENT AND GRADES REFLECTED ON ROADWAY CONCEPT PLANS AND ROADWAY PROFILE PLANS DEPICT THE BASIC PROJECT CONFIGURATION FOR MAINLINE, CROSS STREETS, AND SERVICE ROADS.



SHA

- Maryland Transportation Authority
- Maryland State Highway Administration

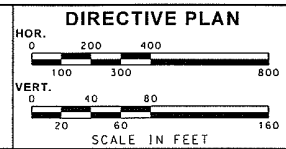

CONTRACT A
AT3765960
ROADWAY PROFILE PLAN
Sta. 398+00 To Sta. 430+00
July 2006 Plate PR-8

MUNCASTER MANOR/
BOWIE MILL ESTATES

MATCHLINE REFERENCE PLATE LS-11

MATCHLINE REFERENCE PLATE LS-09

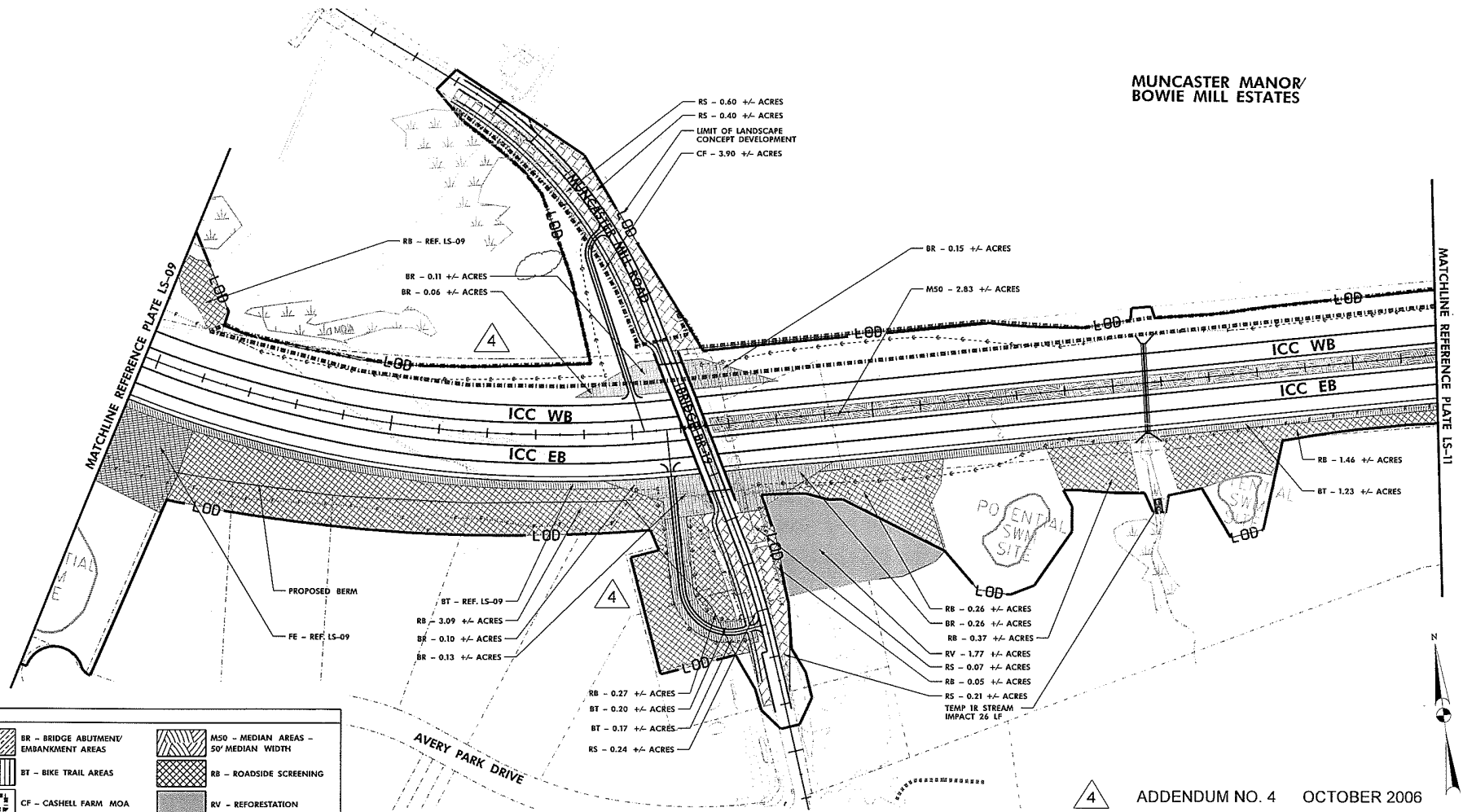

LEGEND	
	BR - BRIDGE ABUTMENT/ EMBANKMENT AREAS
	BT - BIKE TRAIL AREAS
	CF - CASHELL FARM MOA
	DO - DECKOVER STRUCTURE
	FE - FOREST EDGE
	IC - INTERCHANGES/ GATEWAYS
	MSO - MEDIAN AREAS - 50' MEDIAN WIDTH
	RB - ROADSIDE SCREENING
	RV - REFORESTATION
	RS - STREET TREE
	SWM - STORM WATER MANAGEMENT AREA
	WA - SOUND BARRIER/ RETAINING WALL TREATMENT



SHA

- Maryland Transportation Authority
- Maryland State Highway Administration

INDICATIVE PLAN

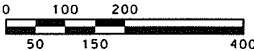

SCALE IN FEET

ADDENDUM NO. 4 OCTOBER 2006

CONTRACT A
AT3765960

INTERCOUNTY CONNECTOR
ICC

LANDSCAPE CONCEPT PLAN

Sta. 279+50 To Sta. Sta. 306+50

July 2006 Plate LS-10



**NORTH BRANCH
STREAM VALLEY PARK**

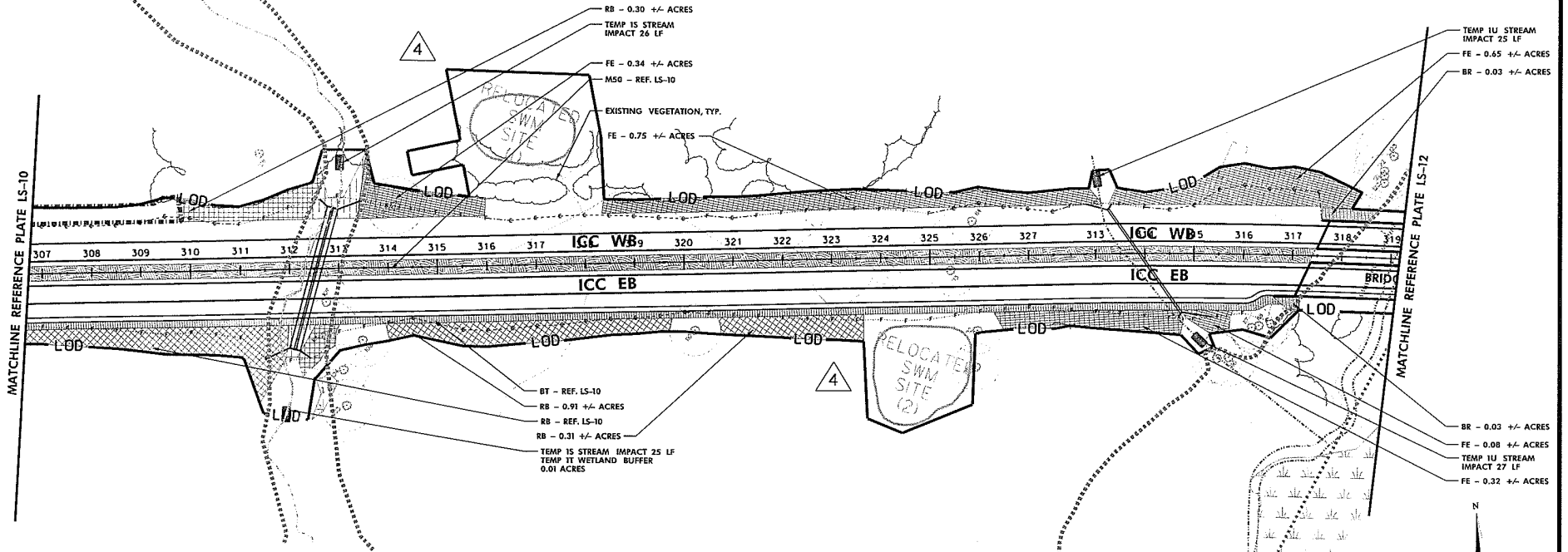

LEGEND

BR - BRIDGE ABUTMENT/ EMBANKMENT AREAS	MSO - MEDIAN AREAS - 50' MEDIAN WIDTH
BT - BIKE TRAIL AREAS	RB - ROADSIDE SCREENING
CF - CASHELL FARM MOA	RV - REFORESTATION
DO - DECKOVER STRUCTURE	RS - STREET TREE
FE - FOREST EDGE	SWM - STORM WATER MANAGEMENT AREA
IG - INTERCHANGES/ GATEWAYS	WA - SOUND BARRIER/ RETAINING WALL TREATMENT

**NORTH BRANCH
STREAM VALLEY PARK**

4 ADDENDUM NO. 4 OCTOBER 2006



SHA

- Maryland Transportation Authority
- Maryland State Highway Administration

INDICATIVE PLAN

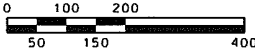

SCALE IN FEET

CONTRACT A
AT3765960

INTERCOUNTY CONNECTOR
ICC LANDSCAPE CONCEPT PLAN

Sta. 306+50 To Sta. 319+00

July 2006 Plate LS-11

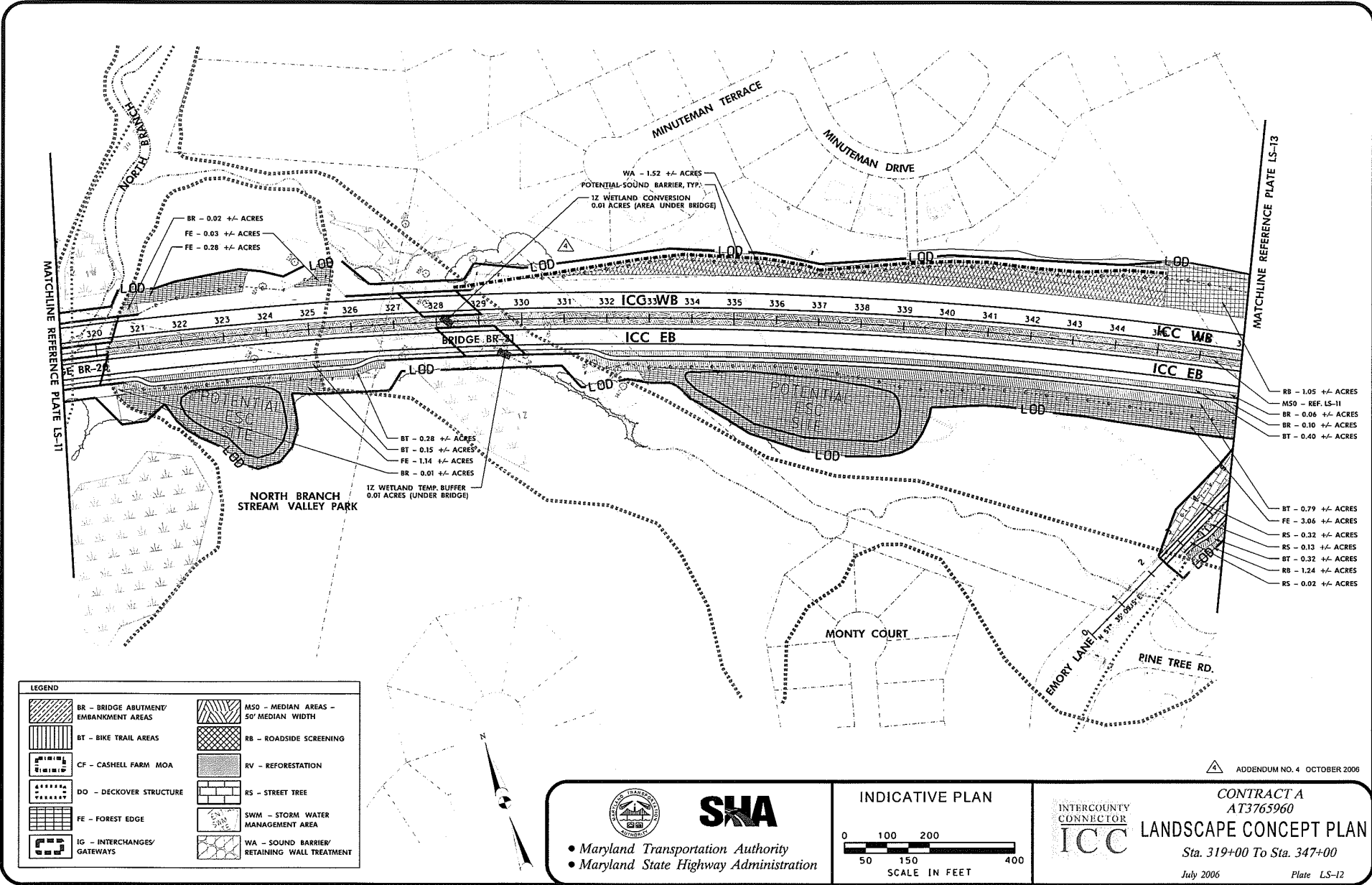

MATCHLINE REFERENCE PLATE LS-11

MATCHLINE REFERENCE PLATE LS-13

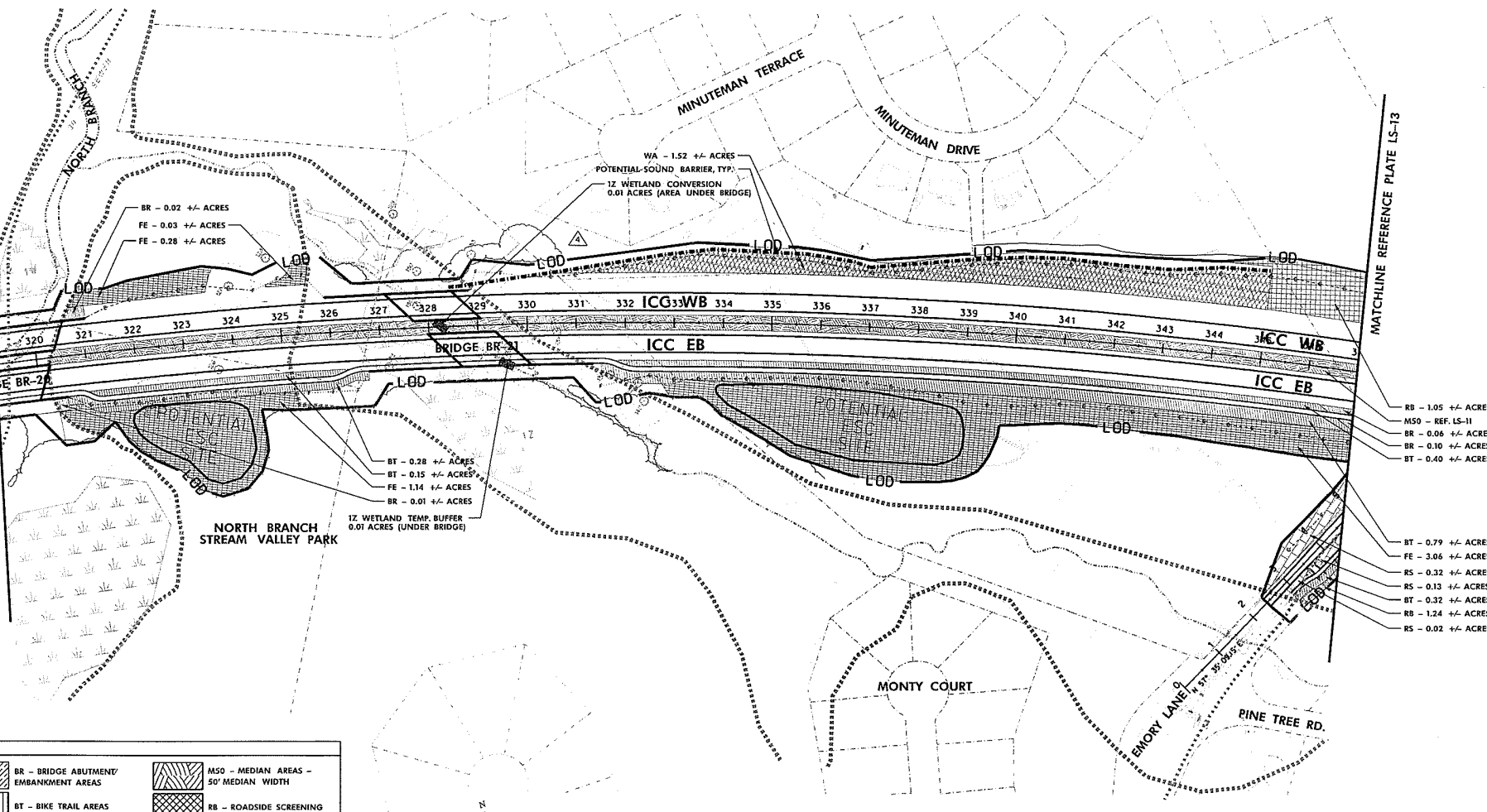

LEGEND			
	BR - BRIDGE ABUTMENT/ EMBANKMENT AREAS		MSO - MEDIAN AREAS - 50' MEDIAN WIDTH
	BT - BIKE TRAIL AREAS		RB - ROADSIDE BUFFER
	CF - CASHELL FARM MOA		RV - REFORESTATION
	DO - DECKOVER STRUCTURE		RS - ROADSIDE STREET TREE
	FE - FOREST EDGE		SWM - STORM WATER MANAGEMENT AREA
	IG - INTERCHANGES/ GATEWAYS		WA - SOUND BARRIER/ RETAINING WALL TREATMENT

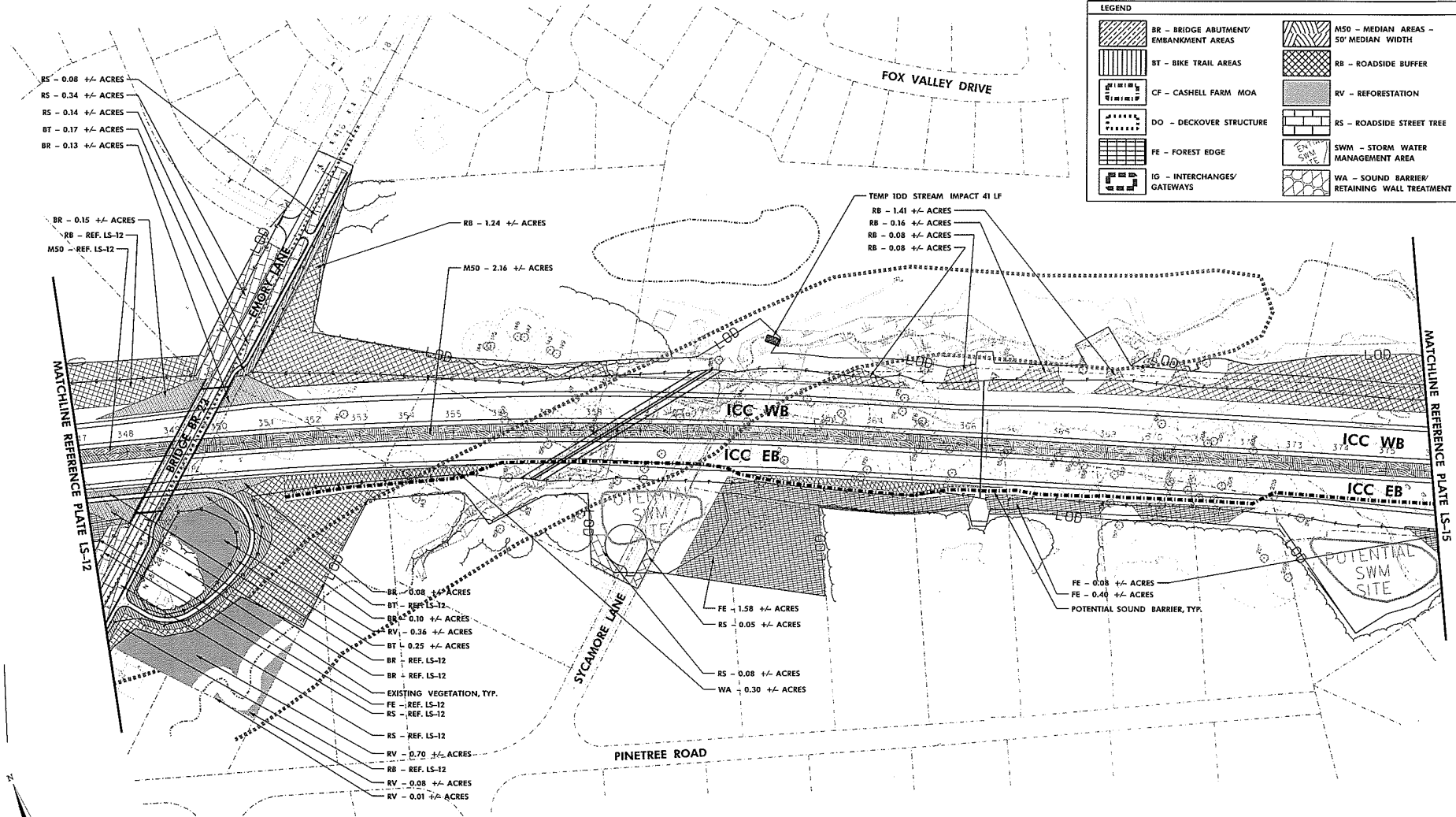

SHA

- Maryland Transportation Authority
- Maryland State Highway Administration

INDICATIVE PLAN

SCALE IN FEET

INTERCOUNTY CONNECTOR

CONTRACT A
AT3765960

LANDSCAPE CONCEPT PLAN

Sta. 347+00 To Sta. 376+00

July 2006 Plate LS-13

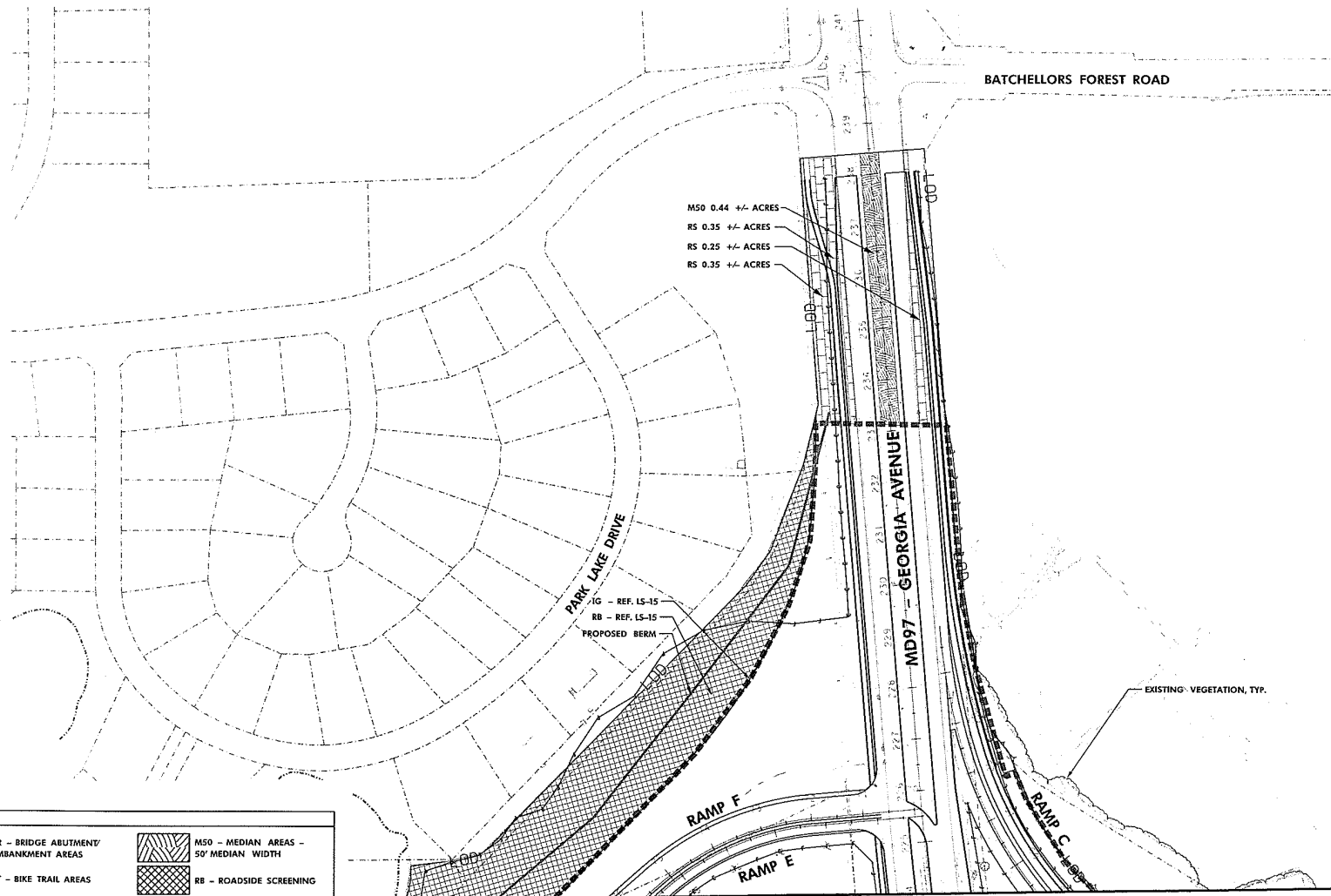

MATCHLINE REFERENCE PLATE LS-15

LEGEND	
	BR - BRIDGE ABUTMENT/ EMBANKMENT AREAS
	BT - BIKE TRAIL AREAS
	CF - CASHELL FARM MOA
	DO - DECKOVER STRUCTURE
	FE - FOREST EDGE
	IG - INTERCHANGES/ GATEWAYS
	MSO - MEDIAN AREAS - 50' MEDIAN WIDTH
	RB - ROADSIDE SCREENING
	RV - REFORESTATION
	RS - STREET TREE
	SWM - STORM WATER MANAGEMENT AREA
	WA - SOUND BARRIER/ RETAINING WALL TREATMENT



SHA

- Maryland Transportation Authority
- Maryland State Highway Administration

INDICATIVE PLAN

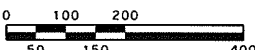

SCALE IN FEET

INTERCOUNTY CONNECTOR

ICC

CONTRACT A
AT3765960

LANDSCAPE CONCEPT PLAN

Sta. 224+00 To Sta. 238+50

July 2006 Plate LS-14

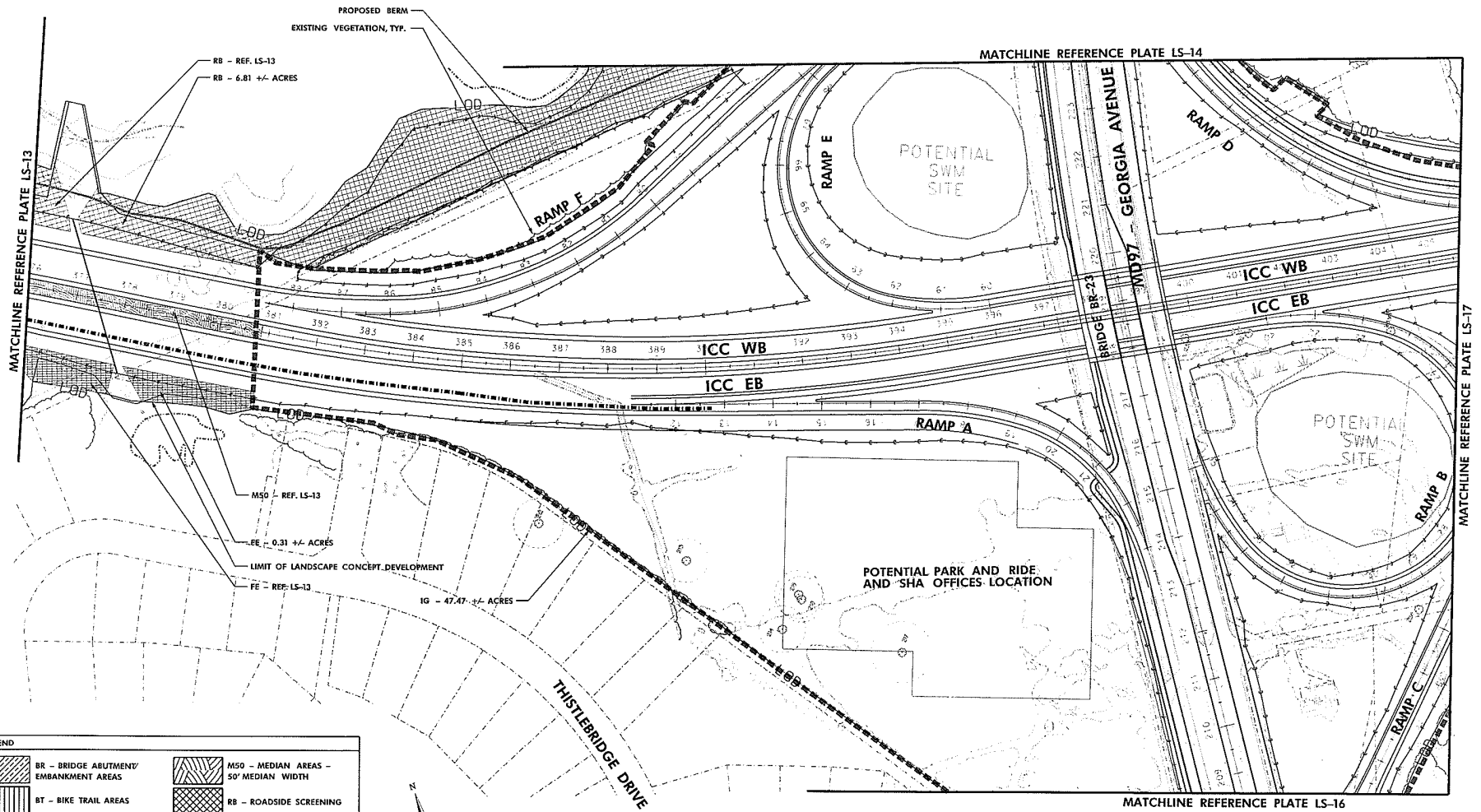

LEGEND	
	BR - BRIDGE ABUTMENT/ EMBANKMENT AREAS
	BT - BIKE TRAIL AREAS
	CF - CASHELL FARM MOA
	DO - DECKOVER STRUCTURE
	FE - FOREST EDGE
	IG - INTERCHANGES/ GATEWAYS
	M50 - MEDIAN AREAS - 50' MEDIAN WIDTH
	RB - ROADSIDE SCREENING
	RV - REFORESTATION
	RS - STREET TREE
	SWM - STORM WATER MANAGEMENT AREA
	WA - SOUND BARRIER/ RETAINING WALL TREATMENT



- Maryland Transportation Authority
- Maryland State Highway Administration

INDICATIVE PLAN

SCALE IN FEET

INTERCOUNTY CONNECTOR

CONTRACT A
 AT3765960
LANDSCAPE CONCEPT PLAN
 Sta. 376+00 To Sta. 405+50
 July 2006 Plate LS-15

LIMIT OF LANDSCAPE CONCEPT DEVELOPMENT
IG - REF. LS-15

MATCHLINE REFERENCE PLATE LS-15

MATCHLINE REFERENCE PLATE LS-17

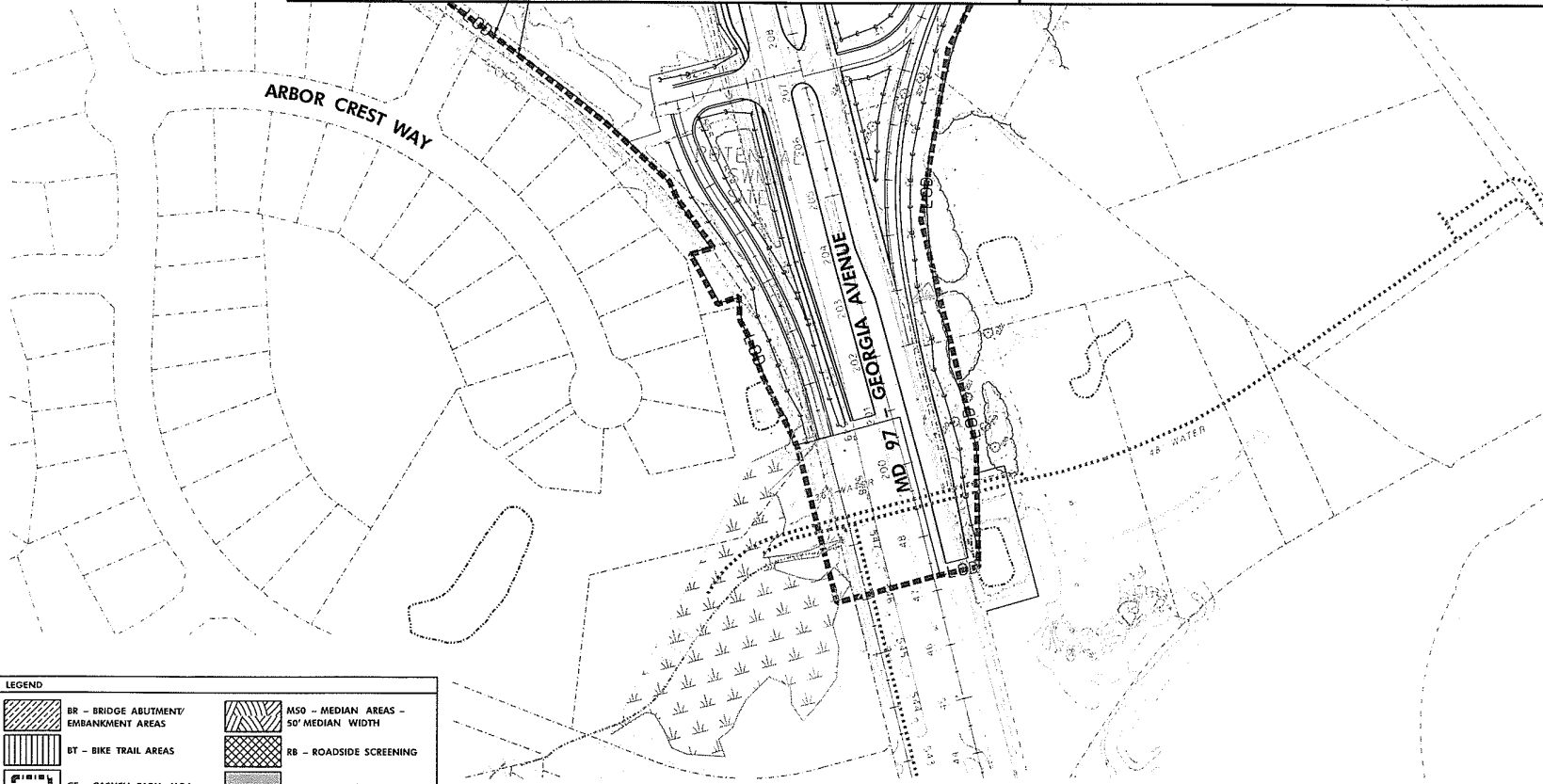

LEGEND	
	BR - BRIDGE ABUTMENT/EMBANKMENT AREAS
	BT - BIKE TRAIL AREAS
	CF - CASHELL FARM MOA
	DO - DECKOVER STRUCTURE
	FE - FOREST EDGE
	IG - INTERCHANGES/GATEWAYS
	MSO - MEDIAN AREAS - 50' MEDIAN WIDTH
	RB - ROADSIDE SCREENING
	RV - REFORESTATION
	RS - STREET TREE
	SWM - STORM WATER MANAGEMENT AREA
	WA - SOUND BARRIER/RETAINING WALL TREATMENT

SHA

• Maryland Transportation Authority
 • Maryland State Highway Administration

INDICATIVE PLAN

SCALE IN FEET

INTERCOUNTY
CONNECTOR

CONTRACT A
AT3765960

LANDSCAPE CONCEPT PLAN

Sta. 208+50 To Sta. 47+50

July 2006 Plate LS-16

